

ALESIS

A6 Andromeda (A6)

Service Manual

P/N: 8-31-0089-C

ATTENTION!

THIS DOCUMENT CONTAINS SENSITIVE
PROPRIETARY INFORMATION. ALL
RECIPIENTS MUST HAVE A CURRENT NON-
DISCLOSURE AGREEMENT ON FILE WITH
ALESIS, LLC.

**DO NOT DISTRIBUTE THIS DOCUMENT IN
ELECTRONIC FORM**

The information in this document contains privileged and confidential information. It is intended only for the use of those authorized by Alesis. If you are not the authorized, intended recipient, you are hereby notified that any review, dissemination, distribution or duplication of this document is strictly prohibited. If you are not authorized, please contact Alesis and destroy all copies of this document. You may contact Alesis at support@Alesis.com.

Copyright © 2003 Alesis, LLC

Version History

Ver A: BRS: added new cover page, added Fatar key removal instructions.

Ver B: 6/13/02 BRS: added more debugging tips, added rev C main board.

Ver C: 10/30/03 ATM: Added additional warning information for Battery replacement (per UL)

Preface

This document is intended to assist the service technician in the operation, maintenance and repair of the A6 Andromeda. Together with the A6 Reference Manual, this document provides a complete description of the functionality and serviceability of the A6. Any comments or suggestions you may have pertaining to the document are welcome and encouraged.

READ THIS!

In addition to any purchase price that Alesis may charge as consideration for Alesis selling or otherwise transferring this service manual (“Manual”) to you, if you are not a service and repair facility (“Service Center”) authorized by Alesis in writing to be an authorized Service Center, Alesis sells or transfers the Manual to you on the following terms and conditions:

Only Service Centers authorized by Alesis in writing are authorized to perform service and repairs covered by an Alesis warranty (if any), and transfer of the Manual to you does not authorize you to be an authorized Service Center. **Therefore, if you perform, or if the Manual is used to perform, any service or repairs on any Alesis product or part thereof, any and all warranties of Alesis as to that product and any service contract with Alesis for that product shall be voided and shall no longer apply for such product, even if your services or repairs were done in accordance with the Manual.**

All service or repairs done by you or with reference to the Manual shall be solely your responsibility, and Alesis shall have no liability for any such repairs or service work. **All such service or repairs are performed at the sole risk of the person performing the service or repairs.** You agree that all such work will be performed in a competent, professional and safe manner at all times and to indemnify and fully hold Alesis and its successors and assigns harmless in the event of any failure to so perform.

Your purchase of the Manual shall be for your own ultimate use and shall not be for purposes of resale or other transfer.

As the owner of the copyright to the Manual, Alesis does not give you the right to copy the Manual, and you agree not to copy the Manual without the written authorization of Alesis. Alesis has no obligation to provide to you any correction of, or supplement to, the Manual, or any new or superseding version thereof.

Alesis shall have the right to refuse to sell or otherwise transfer repair parts or materials to you in its sole discretion. You shall not use, sell or otherwise transfer spare or replacement parts supplied by Alesis to you (i) to repair or be used in products manufactured for or by third parties or (ii) to any third parties for any purpose.

You shall not make any warranties or guarantees with respect to the products of Alesis or the use thereof on behalf of Alesis or in your own name.

The foregoing describes the entire understanding related to sale or transfer of the Manual to you, and no other terms shall apply unless in a writing signed by an authorized representative of Alesis.

All Trademarks are property of their respective companies.

Warnings

TO REDUCE THE RISK OF ELECTRIC SHOCK OR FIRE, DO NOT EXPOSE THIS PRODUCT TO WATER OR MOISTURE.

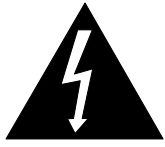

The arrowhead symbol on a lightning flash inside a triangle is intended to alert the user to the presence of un-insulated "dangerous voltage" within the enclosed product which may be of sufficient magnitude to constitute a risk of electric shock to persons.



The exclamation point inside a triangle is intended to alert the user to the presence of important operating, maintenance and servicing instructions in the literature which accompanies the product.

REPAIR BY ANY PERSON OR ENTITY OTHER THAN AN AUTHORIZED ALESIS SERVICE CENTER WILL VOID THE ALESIS WARRANTY.

PROVISION OF THIS MANUAL DOES NOT AUTHORIZE THE RECIPIENT TO COMPETE WITH ANY ALESIS DISTRIBUTOR OR AUTHORIZED REPAIR SERVICE CENTER IN THE PROVISION OF REPAIR SERVICES OR TO BE OR MAKE REPAIRS AS AN AUTHORIZED SERVICE CENTER.

ALL REPAIRS DONE BY ANY ENTITY OTHER THAN AN AUTHORIZED ALESIS SERVICE CENTER SHALL BE SOLELY THE RESPONSIBILITY OF THAT ENTITY, AND ALESIS SHALL HAVE NO LIABILITY TO THAT ENTITY OR TO ANY OTHER PARTY FOR ANY REPAIRS BY THAT ENTITY.

Regarding the Power Supply Fuse



CAUTION: The product under service may employ the use of a replaceable fuse. Danger of fire or electrocution if fuse is incorrectly replaced. Replace with only the same type or equivalent type recommended by the equipment manufacturer.

Regarding the Internal Battery



CAUTION: The product under service may employ the use of an internal battery. Danger of explosion if battery is incorrectly replaced. Replace only with the same or equivalent type recommended by the manufacturer. Dispose of used batteries according to the manufacturer's instruction.

Safety Instructions

Carefully read the applicable items of the operating instructions and these safety suggestions before using this product. Use extra care to follow the warnings written on the product itself and in the operating instructions. Keep the operating instructions and safety suggestions for reference in the future.

1. Power Source. The product should only be connected to a power supply which is described either in the operating instructions or in markings on the product.
2. Power Cord Protection. AC power supply cords should be placed such that no one is likely to step on the cords and such that nothing will be placed on or against them.
3. Periods of Non-use. If the product is not used for any significant period of time, the product's AC power supply cord should be unplugged from the AC outlet.
4. Foreign Objects and Liquids. Take care not to allow liquids to spill or objects to fall into any openings of the product.
5. Water or Moisture. The product should not be used near any water or in moisture.
6. Heat. Do not place the product near heat sources such as stoves, heat registers, radiators or other heat producing equipment.
7. Ventilation. When installing the product, make sure that the product has adequate ventilation. Improperly ventilating the product may cause overheating, which may damage the product.
8. Mounting. The product should only be used with a rack which the manufacturer recommends. The combination of the product and rack should be moved carefully. Quick movements, excessive force or uneven surfaces may overturn the combination which may damage the product and rack combination.
9. Cleaning. The product should only be cleaned as the manufacturer recommends.
10. Service. The user should only attempt the limited service or upkeep specifically described in the operating instructions for the user. For any other service required, the product should be taken to an authorized service center as described in the operating instructions.
11. Damage to the Product. Qualified service personnel should service the unit in certain situations including without limitation when:
 - a. Liquid has spilled or objects have fallen into the product,
 - b. The product is exposed to water or excessive moisture,
 - c. The AC power supply plug or cord is damaged,
 - d. The product shows an inappropriate change in performance or does not operate normally, or
 - e. The enclosure of the product has been damaged.

1.0 Theory of Operation

The A6 is a 16-voice digitally-controlled real analog synthesizer.

The heart of the system is a Motorola Coldfire processor on the Main board. The code for the Coldfire is in flash memory, and is upgradeable through MIDI. There is also a battery-backed SRAM for holding user data.

There is a secondary processor on the Front Panel Left, an 87C52 running code from an EPROM. This processor controls the LCD and does the LED muxing. It does not, however, read the pot values. This is done by the Coldfire.

The analog sounds are generated from 8 Oscillator ASICs that feed 8 Filter ASICs. Each ASIC contains two voices.

The diagram below shows the major A6 PCBs and their functions:

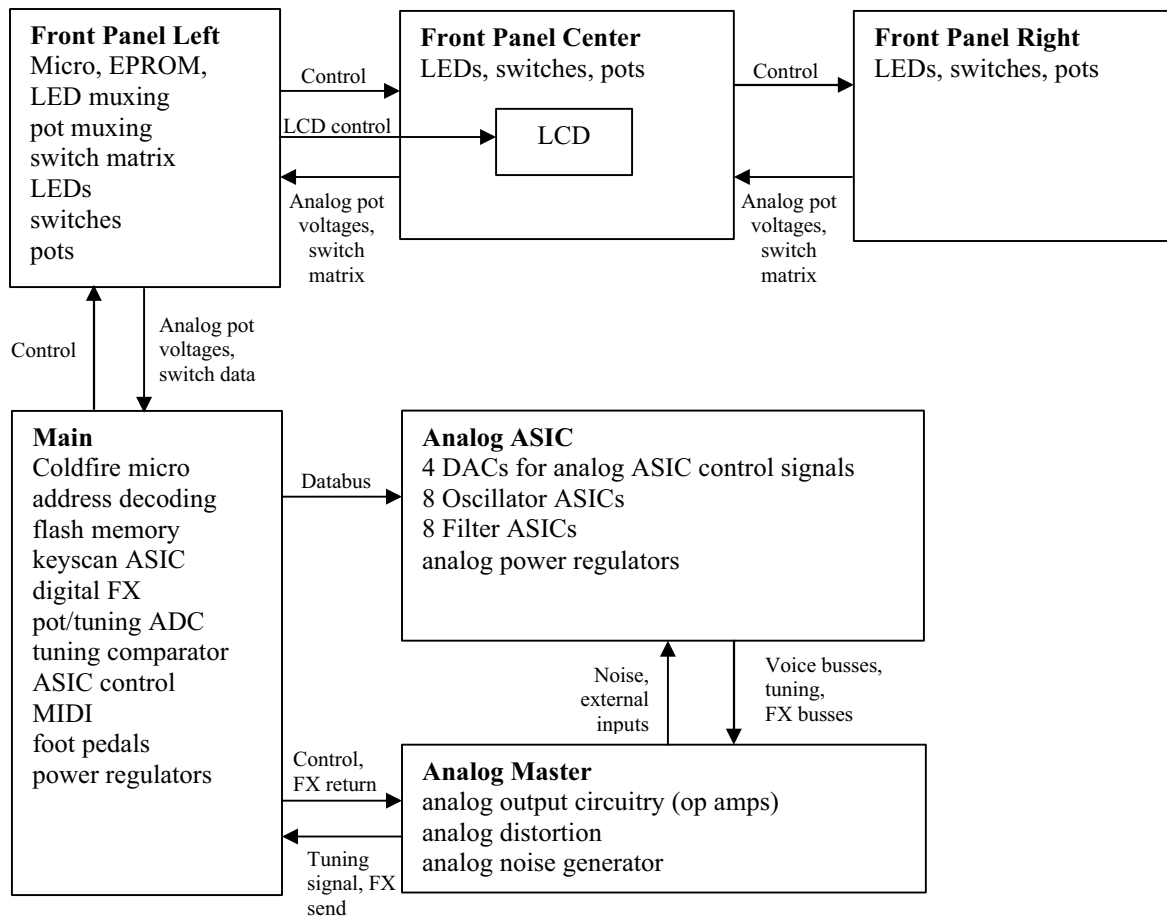

2.0 Test Procedures

This document assumes basic familiarity with the A6 and the A6 User Manual. **Please read Appendix C of the A6 Reference Manual and familiarize yourself with it.** It contains useful information for troubleshooting.

2.10 Power Up Modes

You will need to know the A6 power up modes, since these will be helpful in debugging many problems. The following chart is taken from the A6 User Manual:

POWER UP WHILE HOLDING	FUNCTION
Soft Button 1	Forces A6 to load default Program and Mix. This is useful if the A6 has received corrupted data, causing it to hang.
Soft Button 2	Enters front panel debug mode.
Soft Button 3	Initializes all user RAM. This is also known as a Hard Reset. Warning, this will erase all User Programs and Mixes, replacing them with the factory default User Programs and Mixes!
Soft Button 4	Initializes all Global parameters, including tuning tables.
Soft Button 5	Re-calibrates Mod Wheel and Ribbon Controller.
Soft Button 6	Sends software OS out as MIDI Syx Ex dump.
Soft Button 7	Enables the A6 to receive software Syx Ex dump (OS or bootloader).
Soft Button 8	Replaces the factory default User Programs and Mixes with the User Bank Programs and Mixes. The next time a RAM initialization is done (Soft Button 3), these banks will be used to initialize the User Banks.

2.20 Diagnostic Software Description

The A6 diagnostic software is contained within the boot section of flash memory. The software is intended to be used to test all of the functionality of the front panel and most of the main board. The analog boards are not tested in this mode, since those require the main software engine to be running. Diagnostic mode is entered by holding down soft button 2 while powering on the unit. When you are in Diagnostic mode, you will see the boot software version in the headline.

2.21 Passive Ribbon Test

This test is done automatically when the user enters diagnostic mode. It tests the ribbon for shorts and for proper operation of the left and right calibration points. It is “passive” because it is done while the ribbon is not being used. In fact, *if the ribbon is pressed during this test, it will fail!*

If this test fails, it most likely means the conductive layer of the ribbon (pin 2) is shorted to the resistive layer (pins 1 and 3). It could also mean that one of the pins (1, 2 or 3) is broken or shorted.

2.22 Pitch Wheel Center Test

This test is done automatically when the user enters diagnostic mode. It makes sure that the pitch wheel springs are holding the pitch wheel pot sufficiently within the center of the throw.

2.23 Switch Test

This test is always going on. Simply press a switch! The name of the switch should appear on the screen, and the “Sw :” should be in inverse characters until the switch is released. In addition, if there is an LED near the switch, it will light up. If the switch is pressed a second time, the LED will go off. When the microprocessor detects that a switch has been pressed and released, the word “PASSED” appears on the screen.

When doing this test, it is only necessary to look at the LED (if there is one). If the LED corresponding to the switch you pressed goes on (and no others), the switch is good. Looking at the screen is only necessary for those switches with no LEDs nearby (i.e., the program keys).

Note that if you hold the SHIFT key down while pressing the soft keys, the test associated with the soft key being pressed will not be performed. This is handy when testing the center board keys, when you may not want to execute the test.

2.24 Pot Test

Like the Switch Test, the Pot Test is always going on. Simply turn a pot and you should see the name of the pot on the screen, along with the pot value, which ranges from 0 to 4095. When a pot is turned, the value should change smoothly corresponding to how much the pot is turned. The values should stop changing immediately after (within one second) a pot is turned. If a pot value continues to jitter after you let go, there may be a problem with the pot, the front panel, or the ADC circuitry on the Digital Main Board.

If a pot reaches the nominal min and max values, the word “PASSED” will be displayed on the screen. The passing minimum value is 11 or less. The passing max value is 4084 or greater. It is normal if a pot doesn’t go all the way to zero, or all the way up to 4095, due to offsets in the ADC op amps.

Test	Passing min threshold	Passing max threshold
Pitch Wheel	center value + 1300	center value - 1300
Mod Wheel	1000	3000
Aftertouch	400	4083
Control Foot Pedal	100	2500
Ribbon Right/Left	30	3000
Pots	12	4083

Note that a bad pot may still give a passing message (for example if it jittering), so the user must use some common sense here. If a pot is constantly jittering, there is a problem with the pot (or the unit).

Note that the Pitch Wheel, the Mod Wheel, the Continuous Controller Pedal, Aftertouch, and Ribbon Controller all fall under the pot test. These controllers all have different nominal min and max values. To speed up the test during production, a regular pedal switch may be plugged into the CC Pedal jack and used for this test.

For the pitch and mod wheels, make sure the wheels are not electrically swapped. The pitch wheel is on the left, the mod on the right. The pitch wheel should have a spring and should bounce back to center.

When doing this test, *turn only one pot at a time*. If more than one pot is turned at a time, the test will fail (in boot code V1.20.10 or later), because the software thinks another pot is jittering. Also, turning more than one at a time may cause the display queue to overflow.

2.25 LED Test

To enter this test, press soft button 1. All of the LEDs on the unit should light up. The yellow LEDs should be blinking. Hit button 1 again to turn off the LEDs. Note that any LEDs that were on before this test will be restored and kept on.

The user should make sure that all LEDs go on, that all LEDs are centered in the window, and all LEDs are the correct color.

2.26 MIDI Test

To perform this test, press soft button 2. A MIDI cable should be connected from MIDI OUT to MIDI IN. This test will send a series of bytes through the MIDI port and read them back in. If it passes, the display will read “MIDI TEST PASSED”.

2.27 LCD Test

To perform this test, press soft button 3. All of the pixels on the LCD should turn black. Press any key to exit this test.

2.28 Slow SRAM Test

To perform this test, press soft button 4 and wait a few seconds. This will test the Slow SRAM, or battery backed RAM, on the Digital Main PCB. The first part of this test will test the RAM for stuck bits. The second part will test the RAM address lines to make sure there are no address pins shorted together or open. If this test passes, the display will read “SLOW SRAM TEST PASSED”.

2.29 Test Completion

The DONE soft key (soft key 8) checks to make sure all of the tests have been performed before letting the user exit diagnostic mode into normal keyboard mode. If any test has not been successfully completed, the code will tell the user which test has not been done and remain in diagnostic mode.

In addition, when all of the buttons and pots on a particular board have been successfully exercised, the software will tell the user which boards passed (e.g., “CENTER BOARD PASSED!”) when the DONE soft key is pressed. This is for board testing, when the user is only interested in the status of that board, not the whole system. The software will tell the user which switches or pots were missed on the particular board being tested.

2.30 Front Panel Test Procedure

Connect the following cables/accessories to the A6 external ports:

- 2.311 Connect one end of a MIDI cable (4-17-0003) to the MIDI IN port and the other end to the MIDI OUT port.
- 2.312 Connect Fatar Foot Switch (93) to the CC PEDAL ¼" jack of the FOOT SWITCHES/PEDALS ports.
- 2.313 Connect power cord to A6 power jack.
- 2.314 Verify that A6 unit has current Bootloader and OS code versions with the following steps:
 - a) Switch on power to A6 while holding down round SB#7.
 - b) Verify on A6 LCD:

ANDROMEDA SOFTWARE
BOOTLOADER V01.20.3x OS
V01.40.xx

Note: If Bootloader version is less than "1.20.31" and/or the OS version is less than "1.40.xx", updated software should be loaded (xx - latest version).

- c) Power down A6.
- 2.315 Enter test mode by pressing and holding down SB#2, while switching power ON, until "*** A6 Diagnostic Mode *** " message appears on LCD display. Verify that Blue LED is on.
- 2.316 Test LEDs by pressing SB#1. Verify that all LEDs on the Front Panel light up. Note that the following LEDs should be yellow and flashing:
 - o "Auto Tune"
 - o "Audio Ext In"
 - o "Store"
 - o "Filter Bypass"
 - o "BP Invert"Press SB#1 again to turn off the LEDs.
- 2.317 Test MIDI function by pressing SB#2. Verify that the message "MIDI TEST PASSED!" appears on the lower center area of the LCD display.
- 2.318 Test LCD function by pressing SB#3. Verify that all dark pixels are visible within the darkened area on the LCD display. Press SB#3 again to restore LCD contrast back to normal.
- 2.319 Test LCD contrast pot by turning small contrast knob, found on the right side of the LCD, back and forth while verifying that the contrast changes.

- 2.320 Test SSRAM function by pressing SB#4. Verify that the messages, first, "TESTING SLOW SRAM", then, "SLOW SRAM PASSED!" appears on the LCD display.
- 2.321 Test the Ribbon Controller by starting from the farthest end of either side of the ribbon and sliding finger across it, while pressing down, from left to right and back, verifying that the left and right ribbon values increase and decrease while sliding and that the "PASSED" message appears twice on the LCD display. Note: If only one "PASSED" message appears on the LCD display, stop test and reject unit.
- 2.322 Test each and every Potentiometer, one at a time, from one end of the Front Panel to the other, verifying that both panel and LCD pot names match up and that the "PASSED" message appears (for every pot) on the LCD display. Note: The MASTER VOLUME pot will not show up on the LCD display when actuated.
- 3.323 Test the Pitch/Mod Wheel Assembly by moving the PITCH and MOD wheels while verifying that both the panel and LCD wheel names match up. Verify that the "PASSED" message appears on the LCD display. Also, verify that all buttons on the Pitch/Mod Wheel Assembly actuate their corresponding LEDs and that their panel and LCD names match up on the LCD display.
- 2.324 Test the Front Panel switches by pressing every button on the Front Panel, verifying that both panel and button names on LCD match up and that their corresponding LEDs light up when pressed (some buttons do not have corresponding LEDs). NOTE: Do not press/test SB#1-4 -- they were tested in previous steps.
- 2.325 To test the Aftertouch, press down firmly and hold any of the keys in the keybed until the "PASSED" message appears on the LCD display.
- 2.326 Test the Foot Switches/Pedals ports:
- Connect the Fatar Foot Switch (93) to the CC PEDAL port (1/4" jack) and actuating it while verifying that the "CC PEDAL PASSED" message appears on the LCD display.
 - Connect the Fatar Foot Switch (93) to the SUSTAIN port (1/4" jack) and test by actuating it while verifying that the "SUSTAIN PEDAL PASSED" message appears on the LCD display.
 - Connect the Fatar Foot Switch (93) to the SWITCH port (1/4" jack) and test by actuating it while verifying that the "SWITCH PEDAL PASSED" message appears on the LCD display.
- 2.327 Press SB#8 to identify the remaining tests to be done.
- 2.328 Perform remaining tests as required by A6 diagnostic software.
- 2.329 Follow and repeat steps 1.17 to 1.19 until all remaining tests have been performed.
- 2.330 If unit passes all required tests mentioned in this document, then unit has passed the Front Panel Test!

2.40 Tuning Test Procedure

- 2.401 Power up the A6 while holding down soft button 4. Allow the unit to tune.
- 2.402 Once Oscillator/Filter tuning is finished, press the AUTO TUNE button. If the message "ALL OK" appears on the upper left hand side of the Tuning Results page, then the unit has passed tuning. Otherwise it has failed and you should continue on.
- 2.403 On the Tune results page, note which voices have something other than a "T" under their columns. These are the voices that failed.
- 2.404 If a voice has failed VCA calibration (check the VCA row on the LCD), here's how to tell which ASIC (Oscillator or Filter) has the problem:
- Press soft button 3 (VCACAL).
 - Turn soft knob 7 (VOICE) to select the voice with the failing VCA.
 - Turn soft knob 8 (BAND) to see which VCA's failed for that voice.
 - VCAs 10-13 are in the Osc ASIC. The rest are in the Filter ASIC.
- 2.405 If a voice has failed AUTO calibration (check the AUTO row in the LCD), here's how to tell which ASIC has the problem:
- Press soft button 4 (OSCFRQ).
 - Turn soft knob 7 (VOICE) to select the voice that failed.
 - Turn soft knob 8 (BAND) to see which bands failed for that voice. If the failure is in columns 1 or 2 (OSC), the the Osc ASIC is bad. If the failure is in columns 5 or 6 (FILT), then the Filter ASIC is bad.

2.50 QC Procedures for Repair

These are the procedures that should be done on an A6 after it has been repaired (from the field). Obviously, whatever was fixed should be tested thoroughly.

1. IMPLEMENT OUTSTANDING ECNs.
2. REASSEMBLE. Hot glue any connectors you may have disconnected, then re-assemble the unit.
3. LOAD CODE. Load latest boot and OS code into the unit if necessary (as of 2/13/01 the latest boot code is V1.20.36; the latest OS is V1.40.09). This can be done by using a Data Disk, computer, or another A6. If required, load the boot code first to take advantage of the faster burning capability of the latest boot code. If the unit already has the latest code, power up while holding soft button 4 to clear global variables.
4. AUTO TUNE. After the new code is loaded (or globals are cleared), the unit should automatically do a VCA cal and auto tune. If all voices pass tuning, you should see a “TUNE OK” box in the upper left corner of the Auto Tune page.
5. HEADPHONE LISTENING TEST. Select a simple piano or guitar type of sound (or use the default sound) and play a few notes and chords. Verify that the unit “sounds” in tune through headphones.
6. KEYBOARD TEST. Play a chromatic scale starting from the lowest note to the highest to verify that all of the keys work. Sometimes the keyboard ribbon cables can get pinched when re-attaching the top panel to the bottom panel.
7. RIBBON TEST. Find a patch that uses the Ribbon Controller (for example, Preset 2 050 Upstairs at E’s) and verify that the Ribbon Controller works.
8. FRONT PANEL TESTS. Turn off the unit and power back on while holding soft button 2 to go into front panel debug mode. Perform all tests (knobs, leds, buttons, midi, etc.) and verify that they all pass by pressing the “DONE” button.
9. MAIN OUTPUT TEST. Verify that the Main Outputs are working by connecting the A6 Main Outputs to an amp and speakers and playing the keyboard.
10. AUX OUTPUT TEST. Verify that the Aux Outputs are working by connecting the A6 Aux Outputs to an amp and speakers, then select AUX using the Output button (at the far right of the unit).
11. POWER CYCLE TEST. Cycle power a few times and verify that the unit boots properly each time.

3.0 A6 Troubleshooting

The purpose of this section is to describe some of the most common problems with the A6 and how to fix them.

Before Doing Anything

- Verify the problem before opening up the unit.
- Go into diagnostic mode by holding Soft Button 2 during power up and verify the problem (if applicable).
- Clear memory by powering up holding Soft Button 4 during power up, allow the instrument to re-tune, and see if the problem is fixed.

3.1 General Troubleshooting

While this manual assumes that the reader has a fundamental understanding of electronics and basic troubleshooting techniques, a review of some of techniques may help.

- **Visual Inspection** - A short visual inspection of the unit under test will often yield results without the need of complex signal analysis (burnt, or loose components are a dead giveaway).
- **Self Test** - Alesis products that utilize microprocessor control contain built in test software which exercises many of the units' primary circuit functions. Self test should always be done following any repair to ensure basic functionality.
- **Environmental Testing** - Applying heat and cold (heat gun/freeze spray) will often reveal thermally intermittent components (Clock crystals, I.C.s, and capacitors are particularly prone to this type of failure).
- **Burn in Testing** - Leaving a unit running overnight often reveals intermittent failures such as capacitors that begin to leak excess current after a significant amount of time.
- **Cable Checks** - Wiggling cables can reveal intermittent failures such as loose cables or poorly soldered headers. Remember to check power supply cables as well.
- **Flexing the PC Board** - Poor solder joints and broken traces can often be found by pressing the PC Board in various places.
- **Tapping Components** - Sometimes tapping on a component (particularly crystals) will cause it to fail.
- **Power Down/up** - Turning the unit off and back on rapidly several times may reveal odd reset and/or power supply failures.
- **Reset Threshold** - A Variac (variable transformer) can be used to check reset threshold levels. This can be particularly useful in helping customers with low line problems.
- **Compressors** - Using a compressor/limiter is often helpful when attempting to solve low level noise problems, as well as assisting with DAC adjustments.
- **Sweep Tests** - Sweep generators are very useful in checking the frequency response envelopes of anti-aliasing filters.
- **Piggybacking** - Piggybacking I.C.s is particularly useful when troubleshooting large sections of logic. This is especially true when working with older units.
- **Assembly/Disassembly Organization** - When removing assemblies, organize screws and clips with the assemblies that they were removed from. Organizer trays save a lot of time during re-assembly since similar screws and clips will not be mixed with each other.

3.2 Boot Problems/Unit Hanging

3.201 Unit Doesn't Boot – No Splash Screen

- If the backlight doesn't go on, check 5V power on the top panel.
- Check the ribbon cable going from the Front Panel Left board to the LCD.
- If the backlight goes on, but there is no splash screen, make sure the Front Panel EPROM is properly programmed and seated in its socket (page 4 of the Front Panel Left schematic).
- Make sure crystal for the 8052 is oscillating, and that the proper RD, WR, etc. signals are being generated.
- Make sure the LCD contrast is turned to a good value, and make sure the LCD is working on another unit.

3.202 Unit Doesn't Boot – Stuck at Splash Screen

If the LCD is stuck in the splash screen, "Alesis A6 Andromeda", it means the microprocessor on the Front Panel Left board is working, but may have a communication problem with the Main board, or the Main board itself may have a problem.

- Check the ribbon cable going from the Front Panel Left board to the Main board.
- Make sure the flash on the Main board (U3) is properly programmed.
- Check the pins of the microprocessor (U36), flash (U3), SRAMS (U6,U12,U17), PLD (U29) and other fine-pin-pitch parts on the board for solder shorts or opens.
- Make sure the RESET line is in the proper state.
- Try powering up holding soft button 2 or 3.
- Verify the supply voltages on the Main Board.
- Make sure the crystals are oscillating on the Main Board. If M1 is not oscillating, then the unit will be able to boot into diagnostic mode, but not normal mode (this is because the normal mode software is stuck trying to initialize the DSP chip).
- Check the main board U12 IS61LV25616 SRAM. If the brand is ICSI, try replacing it with an ISSI brand SRAM. The way to tell if this is the problem is to power up twice quickly. If it makes it past the boot screen the second time, this might be the problem.

3.203 Unit hangs after power up or when selecting a Program or Mix

- The Mix or Program is corrupted. Power up while holding Soft Button 4 (which clears Global Memory, but not the User bank) or Soft Button 1 (which loads a default Program after powerup). Search for the corrupted program and write over it, or clear user memory entirely by powering up while holding Soft Button 3.

3.204 Knobs and keyboard don't work, unit won't tune (stuck at "stabilizing asic temperatures" popup)

- This is a specific problem. Check the BA02 POWER_FAIL signal. It should be high (around 7V) during normal operation. A unit with this signal low exhibited the above symptoms. Swapping the BA02 fixed the problem.

3.205 Unit won't go into any powerup modes (diagnostic, load code, clear memory)

- Make sure none of the front panel buttons is stuck down.

3.3 Front Panel Problems

3.301 Buttons Don't Work or are Intermittent

- Make sure you have the latest version of the Front Panel Left PCB. If not, make sure all of the ECNs are properly implemented. (Rev B of the board needs a 1000pF cap soldered across pins 10 and 11 of U20).
- Make sure the diode that goes with the button is oriented correctly. If more than one button doesn't work, there may be a problem with whole a row or column. See if the failing buttons correspond to a row or column.

3.302 Knobs Jitter or Don't Reach Maximum Value or Don't Work

- Make sure the ribbon cable going from the Main board to the Front Panel Left board is securely seated.
- Make sure the large 60-pin ribbon cable going across the Front Panel boards is properly seated.
- Make sure the caps and resistors at the Main Mux (upper left corner of page 2 of the Main PCB schematic) are the correct value and are properly soldered.
- Knob jitter can be caused by voltages exceeding 5V at the ADC mux input on the Main board. Check the inputs to U21 on the Main board. If any voltages exceed 5V, find the source (probably the tuning or temperature bus from the ASICs). One of the ASICs might be bad. [ECN was written to remove R62 on Main PCB – make sure it was done].
- Swap Front Panels to see if the problem is with the Front Panel or Main Board.
- Make sure the unit has the latest software (V1.40.09 or later has new anti-jitter knob code).
- Make sure the knob caps aren't pushed in so much that they're touching the front panel. Pull the plastic cap slightly so that it is not sitting against the metal.
- Try looking at the muxed analog pot signal at the input of the pot ADC (page 2 of the Main PCB schematic), U27 pin 1. The waveform should look like a "skyline", with each "building" representing a pot level. If you turn all of the knobs down (to the left), the waveform should be mostly flat, except for things like the pedal inputs, which are normally high. If you see no signal here, it means the pot signal is not getting to the ADC and therefore the micro.

3.303 LED Doesn't Work

- Make sure the LED is soldered and oriented correctly.
- If several LEDs don't work, the problem may be with a row or column in the LED matrix. Check the row and column drivers.

3.304 Keys Don't Work

- Make sure the two ribbon cables going from the Main board to the Fatar keybed are not being smashed by the Ribbon Controller bracket. Make sure the cables are routed through the opening in the bracket. If the cables were damaged, replace them.

3.305 Ribbon Controller Doesn't Work

- Re-calibrate the ribbon by powering up while holding Soft Button 5. Make sure nothing is touching the Ribbon Controller during this process.
- Go into diagnostic mode by holding down Soft Button 3 during power up. Verify ribbon operation.
- Make sure the Ribbon Controller cable is plugged in properly.

- Make sure the Ribbon Controller has been assembled correctly. Swap with a different Ribbon Controller and see if the problem goes away.

3.306 LCD Backlight is Dim

- Make sure the LCD has the backlight resistors properly installed.

3.307 Pitch/Mod Wheels Don't Work

- Re-calibrate the ribbon by powering up while holding Soft Button 5. Make sure the pitch wheel is centered and the mod wheel is all the way down during this process.
- Go into diagnostic mode by holding down Soft Button 3 during power up. Verify wheel operation. The wheel values should increase as the wheels are turned up.
- Make sure the wheels are wired up properly (i.e., wires are not reversed).

3.308 RAM Card Slot Doesn't Work

- Make sure the RAM card is compatible with the A6 (must be Type I PCMCIA SRAM card 2MB or less).
- Make sure the write protect on the card is OFF.
- Make sure the RAM card battery is good.
- Check the pins of the card connector J7 on the Main Board. Make sure none are bent or broken.
- Make sure all of the pins of J7 are soldered correctly.
- Make sure U15 is soldered correctly.
- Test continuity of traces to and from U15.
- Replace U15.

3.4 Audio Problems

3.401 No Output from Main or Headphone Outputs

- Make sure the volume cable is securely plugged in at the Front Left Main board and the Analog Master board.
- Make sure the Dual Master Volume Pot circuit (page 2 of the A6 Front Panel Left schematic) has been soldered correctly. The op amp might be blown.
- Check output mute transistors (Q1 and Q2 on page 3 of the Analog Master PCB). They may be blown and need to be replaced.
- If you are in a country that uses lower power voltages (i.e., Japan), try tweaking the AC supply voltage to the A6 (using a device like the Elgar). If it's sensitive, the BA02 power supply may be bad.

3.402 Low Output from Main or Aux Outs

- Try replacing the output mute transistors Q1-Q4. If any one of these are bad, it could cause low output on all four outputs.

3.5 Tuning Problems

3.501 Single Voice Fails Tuning

- Make sure all of the components around the ASIC with the failing voice are soldered properly and are the correct value.
- If they are, then the ASIC for that voice may be bad. Replace it and re-test.

3.502 All Voices Fail Tuning

- One of the ASICs could be shorting the tune busses. Turn off background tuning and check the voltage on `FILT_ASIC_VCA_CAL_BUS` and `ASIC_TUNE_BUS` on the Analog ASIC board. The voltage should be 2V. If not, remove ASICs (or disconnect from the bus) until you've identified which one is shorting the line.
- Check the ribbon cables going from the Analog ASIC board to the Analog Master board and the Main board.

3.503 Voice 2 Fails Tuning or ASIC Test – Has Problem with Pre Filter Path

This is a very specific problem on the Analog ASIC PCB. R73 and R74 are swapped in the silkscreen, so the wrong parts are stuffed on the board. We found this problem on both the A6 sample and the separate Analog ASIC board sent by Yahorng.

Take a look at an Analog ASIC board, near R74 and R73. The "R74" silkscreen is on the left resistor, while the "R73" silkscreen is on the right resistor. But, actually, the left resistor is R73 and the right is R74.

So, the left resistor should be a 20K resistor. The right one should be a 0 ohm resistor. Look around the other ASICs to see what it should look like.

3.6 Mechanical Problems

3.601 Endcaps Are Loose

- Remove the endcap from the top panel. This will require removing the associated front panel PCB. The plastic bosses may be stripped. If so, replace the endcap. Otherwise, apply Loctite to the screws and re-assemble.

3.602 Keys Make “Clanging” Noise when pressed hard

- Re-seat the springs at the rear of the keys making the noise.

3.603 Pitch Wheel has Too Much Play at Center Position

- Inspect the pitch wheel spring. It should have heat shrink tubing all the way up the “arms” of the spring. If the tubing doesn’t run all the way, the wheel will have room to wiggle between the arms.

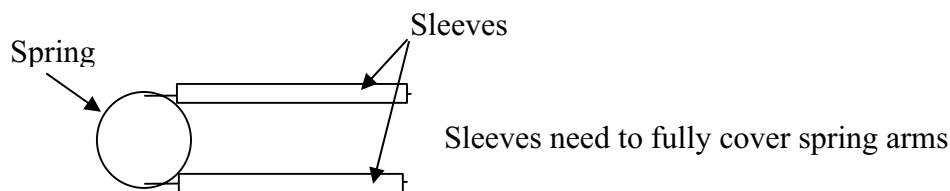

3.604 Keys Feel “Mushy” When Pressed

- The foam on the top panel is pushing down too hard on the back end of the keys, interfering with the motion. The problem is with the ribbon controller bracket (9-30-1314-B). When disassembling the unit, you may notice that the ribbon bracket holes don’t line up very well with the bottom panel holes. As you force the holes into alignment to put the screws in, the ribbon controller bracket pulls the top panel metal slightly (near the end of the keys). This squeezes the foam against the ends of the keys. Inspect the ribbon bracket and make sure it is bent at the correct angle. You can manually bend the bracket until the holes line up and the problem is fixed.

4.0 Repair Procedures

This section contains repair procedures for the A6.

4.1 Opening the Unit

Before opening the unit, make sure you and your work area are properly grounded!!!! The A6 circuitry (especially the analog ASICs) is extremely sensitive to static electricity!!!!

4.11 Opening the Unit

- Unscrew the screws on the bottom of the unit, but do not unscrew the 12 screws directly under the Fatar keyboard. These hold the keys in place.
- Unscrew the 5 screws on the rear panel of the unit.
- Grab the endcaps and gently lift the top panel away from the bottom panel, rear end first. Be careful not to damage the rear end of the plastic endcaps. That section is fragile.
- When the top panel is free, tilt it backwards and place it behind the bottom panel.

4.12 While the Unit is Open

- Implement outstanding ECNs and test the unit for correct implementation.
- Hot-glue any connectors you may have disconnected.
- Load the latest OS code into the unit.
- Follow the QC test procedure outlined in the previous section of this manual.

4.13 Closing the Unit

- If you had to unscrew any screws that go into plastic, apply Loc-Tite when re-screwing them.
- Replace the top panel by aligning the front end first, then carefully lowering the back end.
- Make sure the metal bracket right beneath the Ribbon Controller does not pinch the ribbon cables coming from the keyboard.
- Re-screw all of the screws.

Top Panel (with Front Panel Right board removed)

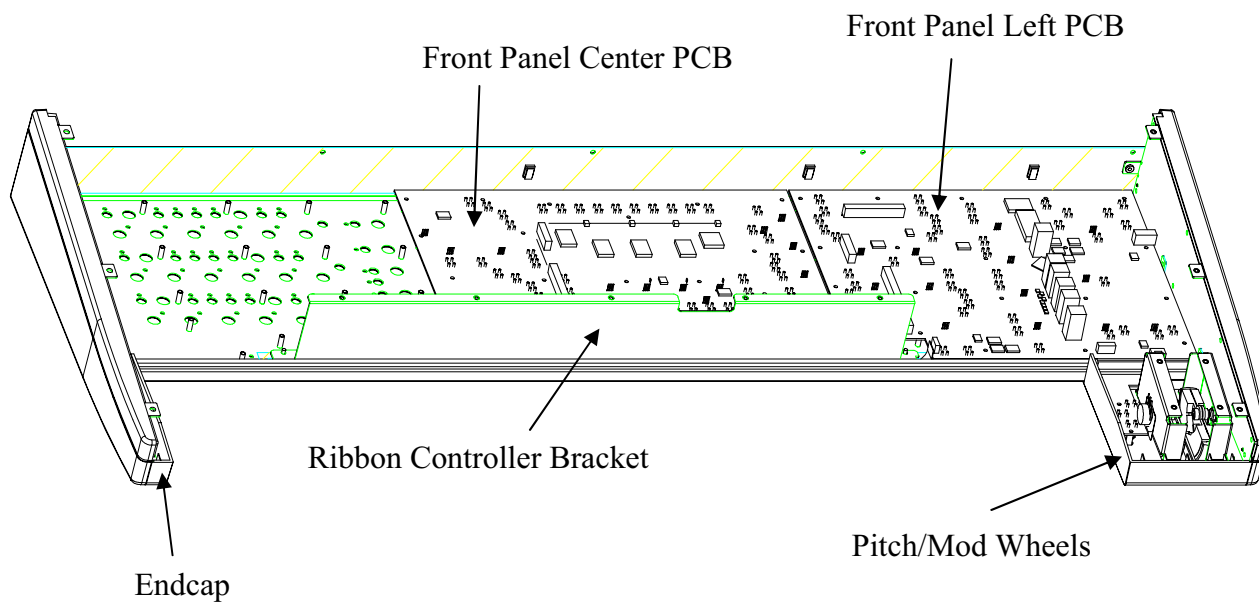

Bottom Panel

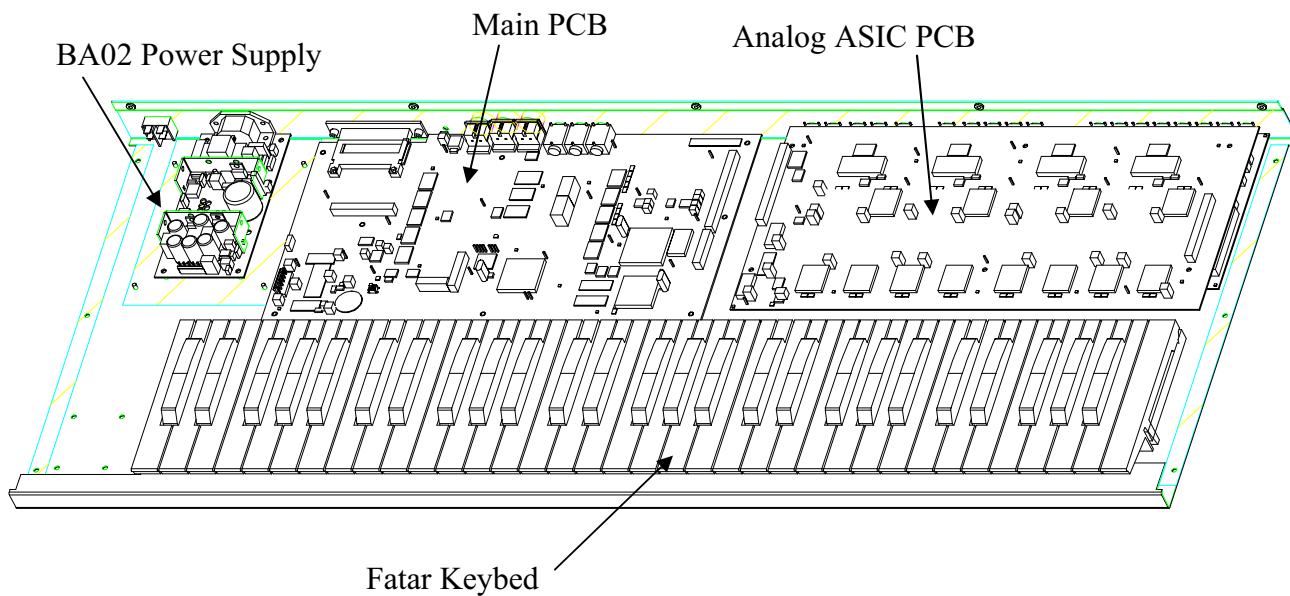

4.2 Replacing Keys

This section describes how to replace the Fatar keyed keys. You do not need to remove the keyboard from the bottom panel to remove a key.

- 4.21 Remove the spring by gently pulling it up and out with a pair of pliers. Do not pull too much or else the spring will get stretched out.

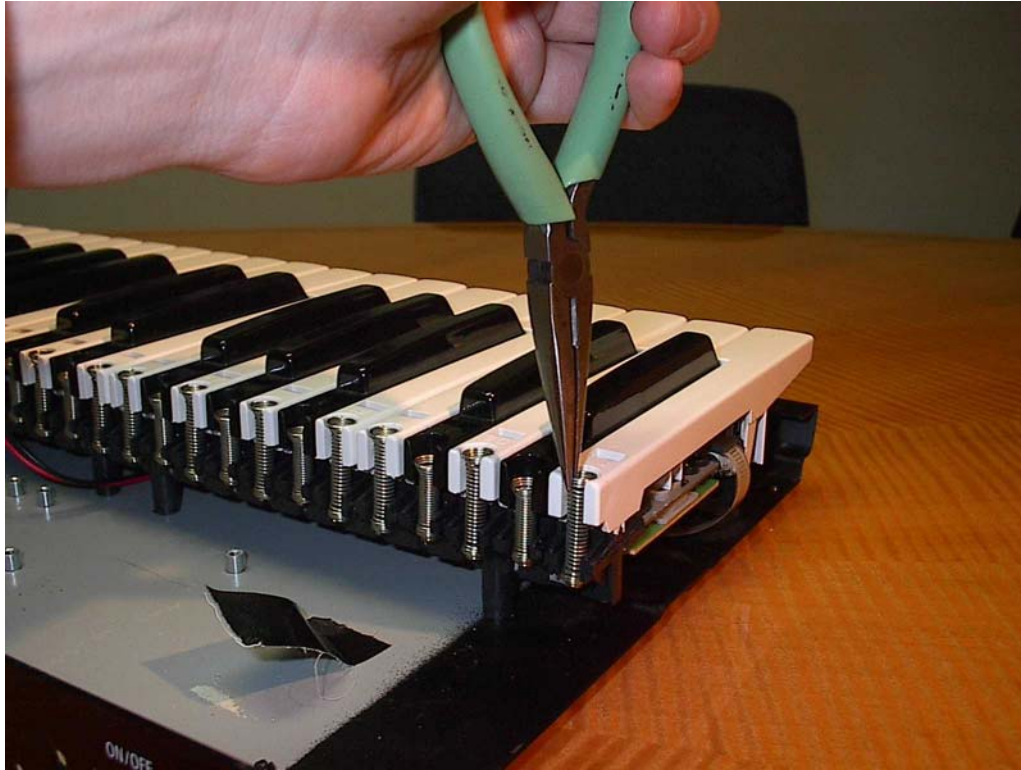

4.22 Insert a flat-head screwdriver into the top slot of the key.

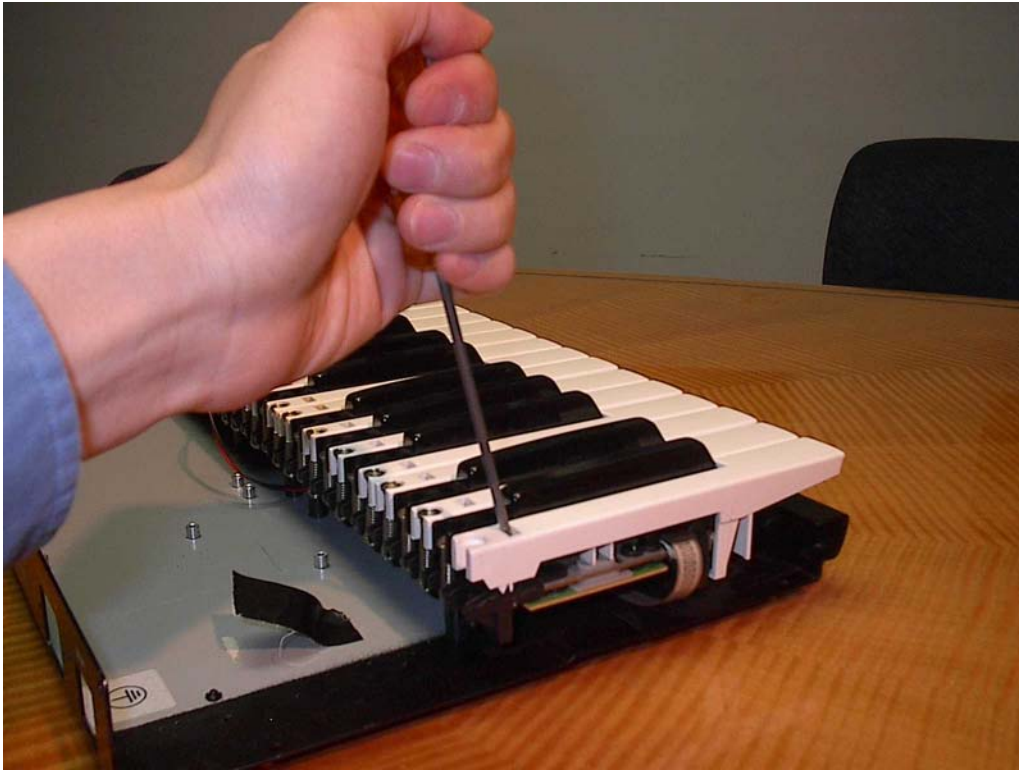

4.23 Use the screwdriver to bend the tab inside the key while pushing the key forward and up.



4.24 Slide the key off the keybed.

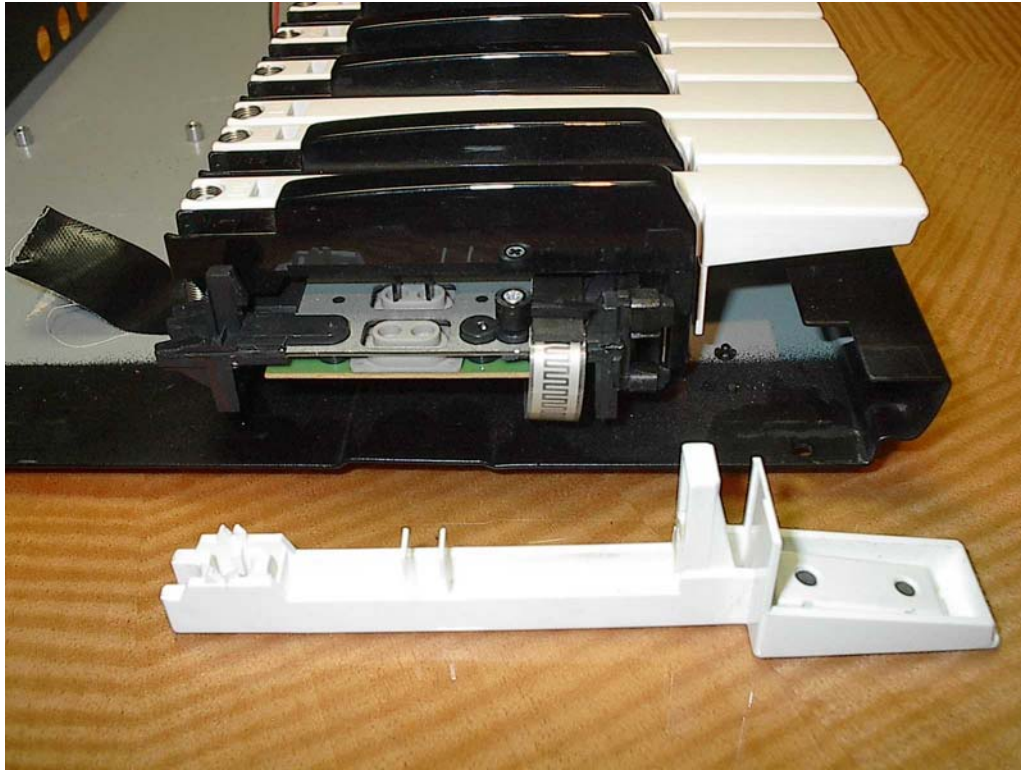

ALESIS ANDROMEDA (A6)

BOM PCB FILES

A6-UL BOM
2002-09-18

Part.Number	Description	Qty Per	Ref.Designator
A6-UL	KEYBOARD ANALOG SYNTH ANDROMEDA A6 - UL	1	
7-41-0005	CABLE POWER UL/CSA SJT	1	
7-51-1219-B	SHEET "WELCOME TO ALESIS FAMILY" 5 x 8"	1	
A6	KEYBOARD ANALOG SYNTH ANDROMEDA A6	1	
4-18-1200-C	CABLE DIL RIBBON 16-PIN 0.1" 260mm M-F REVRS SPC	2	KEYBOARD TO MAIN PCB
4-19-0017-A	CABLE SIL 8-PIN 2mm SHIELDED A6	1	ANALOG MASTER TO LEFT PANEL
4-19-0216-A	CABLE SIL 2-PIN 3.96mm (P/S-TO-SWITCH) A6	1	
4-19-1712-B	CABLE SIL 12-PIN-TO-2-CON POWER HARNESS A6	1	
4-19-2002	CABLE AFTERTOUCHE	1	KEYBOARD TO MAIN PCB
4-70-2007-A	CABLE RIBBON DIL 20-PIN 2.54mm 220mm F-F A6	1	LEFT PANEL TO LED
4-70-2600-A	CABLE RIBBON DIL 26-PIN 2.54mm 80mm F-F A6	1	DIGITAL MAIN TO ANALOG MASTER
4-70-4004-A	CABLE RIBBON DIL 40-PIN 2.54mm 250mm F-F A6	1	LEFT PANEL TO MAIN PCB
4-70-5010-B	CABLE RIBBON DIL 50-PIN 2.54mm 85mm F-F A6	1	ANALOG MASTER TO ANALOG ASIC
4-70-6000-C	CABLE RIBBON DIL 60-PIN 2.54mm 550mm F-F A6	1	LEFT-CENTER-RIGHT PANEL PCB's
4-70-6001-B	CABLE RIBBON DIL 60-PIN 2.54mm 110mm F-F A6	1	MAIN TO ANALOG ASIC
5-00-0106	SCREW M3 x 8mm PPZ w/NYLOC PATCH	84	ALL PCBs
5-00-0358	SCREW M3.5 x 8 PPB PLASTIC	20	8 ON EACH ENDCAP, 2 ON KEYEND, 2 ON P/M BEZEL
5-00-1308	SCREW M3 x 8mm PPB PLASTITE	2	PCMCIA CARD
5-00-3508	SCREW M3.5 x 8 PPB	26	3 EACH ON ENDCAP TO TOP PANEL, 20 ON TOP TO BOTTOM
5-00-4012	SCREW M4 x 12 PHIL-TRUSS SMA BLK	14	12 FOR KEYBED, 2 FOR IEC CONNECT
5-01-0034	WASHER FLAT M3	2	RIBBON CONTROLLER TO TOP PANEL
5-02-6328	NUT KEP M3 STEEL/ZINC	18	RIBBON CONTROLLER TO TOP PANEL
5-03-0028-A	STANDOFF M3 x 20mm M-F BRASS	6	ANALOG MASTER TO BOTTOM PANEL
5-04-1007	FASTENER SNAP RIVET	4	FEET, BOTTOM PANEL
5-10-1004	TIE WRAP 4" LOCKING WHITE	2	POWER SUPPLY
6-03-0001	SWITCH ROCKER DPST 250VAC 10A	1	
7-10-0021	PEDAL SUSTAIN W/BOX S5	1	
7-10-0022	KEYBOARD 61-KEY	1	
7-50-0138	STICKER BARCODE S/N A6	1	
7-51-0089-B	MANUAL REFERENCE A6 - REV B	1	
7-53-0168	STICKER YAHORNG FACTORY ID "T M C"	1	Place on rear or bottom of unit with the appropriate letter circled.
7-80-0134	STRIP CARDBOARD	1	
7-80-0258	BOX GIFT A6	1	
7-80-0259	BOX ACCESSORY W/INSERT A6	1	
7-80-0260	BOX SHIPPING A6	1	
7-81-0158	ENDCAP POLYFOAM LEFT A6	1	
7-81-0159	ENDCAP POLYFOAM RIGHT A6	1	
7-81-0161	SUPPORT CENTER POLYFOAM A6	1	
7-94-1015	POLYBAG 10 x 15 - 4 MIL	1	
7-94-2448	POLYBAG 24 x 48" - 4 MIL	1	
9-01-0026-D	PANEL TOP A6 - REV D	1	
9-01-0027-F	PANEL BOTTOM A6 - REV F	1	
9-03-1308-B	BRACKET LEFT END A6 - REV B	1	
9-03-1309-B	BRACKET RIGHT END A6 - REV B	1	
9-10-0038-A	BEZEL KEY END A6 - REV A	1	
9-10-0039-A	BEZEL LCD A6 - REV A	1	
9-11-0002-C	COVER RIBBON END A6 - REV C	2	
9-13-0005-A	OVERLAY TOP PANEL BLUE A6 - REV A	1	
9-15-0206	SUPPORT CABLE ADHESIVE-BACKED-LOW-PROFILE-SIDE-ENTRY NYLON	4	
9-15-0213	FOOT ROUND LARGE G8/A6	4	
9-15-0231-A	ENDCAP LEFT A6 - REV A	1	
9-15-0232-A	ENDCAP RIGHT A6 - REV A	1	

A6-UL BOM
2002-09-18

9-15-0246-A	SLEEVE POT-BUSHING DUAL A6 - REV A	5	(4)under large knob (1)Master Volume control under medium knob
9-15-1150	BEZEL CARD S6	1	
9-15-1360-A	CAP ROUND SWITCH GREY A6 - REV A	67	
9-15-1361-A	CAP RECTANGULAR SWITCH GREY A6 - REV A	18	
9-15-1362-A	CAP RECTANGULAR SWITCH BLACK A6- REV A	21	
9-15-1363-A	CAP ROUND SWITCH DARK BLACK A6 - REV A	58	
9-15-1364-A	CAP ROUND SWITCH RED A6 - REV A	1	
9-34-0040-C	FOAM STRIP KEYBOARD A6 - REV C	1	
9-44-0003	LCD MODULE 240x64 W/HEADER	1	
9-96-0066	ASSY KNOB/CAP SMALL A6	17	Includes (1)9-15-0167-A (1)9-15-1359-A
9-96-0067	ASSY KNOB/CAP MEDIUM A6	51	Includes:(1)9-15-0166-B (1)9-15-1358-A
9-96-0068	ASSY KNOB/CAP LARGE A6	4	Includes:(1)9-15-0165-B (1)9-15-1357-A
9-79-0193	ASSY PCB MAIN A6	1	
0-15-0333	RES 33K OHM 1/10W 5% 0805	1	R117
0-15-0399	RES 3.9 OHM 1/10W 5% 0805	1	R20
0-16-1000	RES 100 OHM 1/10W 1% 0805	2	R72 R89
0-16-1001	RES 1.00K OHM 1/10W 1% 0805	18	R3 R9-10 R22 R28 R50-52 R57-58 R60 R63 R66-67 R71 R77 R108 R111
0-16-1002	RES 10.0K OHM 1/10W 1% 0805	5	R2 R75 R80 R103 R110
0-16-1004	RES 1.00M OHM 1/10W 1% 0805	3	R56 R86 R98
0-16-1009	RES 10.0 OHM 1/10W 1% 0805	3	R24 R27 R68
0-16-1101	RES 1.10K OHM 1/10W 1% 0805	3	R53-55
0-16-1651	RES 1.65K OHM 1/10W 1% 0805	1	R106
0-16-1821	RES 1.82K OHM 1/10W 1% 0805	4	R30 R33 R38 R40
0-16-2210	RES 221 OHM 1/10W 1% 0805	16	R4-8 R21 R23 R25 R31 R41 R44 R64 R88 R91 R95 R112
0-16-4323	RES 432K OHM 1/10W 1% 0805	1	R81
0-16-4750	RES 475 OHM 1/10W 1% 0805	3	R1 R79 R83
0-16-4751	RES 4.75K OHM 1/10W 1% 0805	14	R11-13 R17 R65 R78 R82 R85 R90 R92 R94 R99-101
0-16-4752	RES 47.5K OHM 1/10W 1% 0805	4	R47-49 R84
0-16-4759	RES 47.5 OHM 1/10W 1% 0805	7	R69-70 R73-74 R76 R96-97
0-16-6812	RES 68.1K OHM 1/10W 1% 0805	1	R87
0-16-8251	RES 8.25K OHM 1/10W 1% 0805	8	R26 R29 R32 R34 R36-37 R39 R43
0-17-0333	RES CHIP ARRAY 4 X 33K OHM 1/16W 5% ISOLATED c-c=0.8mm	4	R113-116
0-17-1221	RES CHIP ARRAY 4 x 220 OHM 1/10W 5% ISOLATED c-c=1.27mm	7	R59 R93 R102 R104-105 R107 R109
0-17-1470	RES CHIP ARRAY 4x47 OHM 1/10W 5% ISOLATED c-c=1.27mm	9	R14-16 R18-19 R35 R42 R45-46
1-08-0476	CAP 47uF ELEC 25V 2.5x6.3x7mm	7	C90 C106 C119 C126 C130 C138 C143
1-10-1102	CAP 10uF ELEC 50V 2x5x7mm	12	C17 C20 C28 C30 C33 C41 C43 C49 C74 C79 C87 C141
1-55-0391	CAP 390pF NPO 0805 5% 50V	4	C23-24 C39 C44
1-55-0474	CAP 4700pF X7R 0805 50V	2	C19 C47
1-55-0561	CAP 560pF NPO 0805	6	C59-62 C69 C76
1-56-0102	CAP 1000pF NPO 0805 5% 100V	4	C3 C29 C38 C72
1-56-0103	CAP 0.01uF X7R 0805	105	C1-2 C4-16 C18 C21-22 C25-27 C31-32 C34-37 C40 C42 C45-46 C48 C50-54 C56-58 C64-68 C73 C77 C80 C84 C89 C91-92 C94-105 C107-115 C118 C120 C122-125 C127 C129 C131-132 C134-137 C139-140 C142 C144-158
1-56-0104	CAP 0.1uF X7R 0805 10% 50V	4	C78 C85 C88 C93
1-56-0151	CAP 150pF NPO 0805	1	C83
1-56-0220	CAP 22pF NPO 0805 5% 50V	6	C55 C63 C117 C121 C128 C133
1-56-0334	CAP 0.033uF X7R 0805 50V	1	C116
1-56-0474	CAP 0.47uF X7R 0805 16V	2	C70 C75
2-11-1317	REG ADJ-VOLTAGE LM317 POS 1.2-37V TO-220	1	U41

A6-UL BOM
2002-09-18

2-11-2940	REG VOLTAGE LM2940C 5V TO-220	2	U28 U38
2-24-0138	IC OPTO-ISOLATOR 6N138	1	U1
2-27-0021	ASIC KEY-SCAN PLCC-68	1	U40
2-27-0022	ASIC DSP1 DIG-FX 84-PIN	1	U23
2-50-4148	DIODE SIGNAL LS4148 MELF	5	D2-6
2-51-0140	DIODE POWER SCHOTTKY MBRS140LT3 40V 1A	1	D7
2-51-4401	TRANS NPN 2N4401 40V 1A SOT-23	2	Q1-2
2-62-0005	IC 74AHC1GU04 SINGLE INVERTER SOP-5	3	U19 U35 U39
2-62-0008	IC 74AHC08D QUAD 2-IN POS AND SOP-14	1	U13
2-62-0074	IC 74AHC74 DUAL POS-EDGE D FF W/CLR & PRESET SOP-14	1	U34
2-62-1014	IC 74AHCT14 HEX SCHMITT-TRIGGER INVERTER SOP-14	4	U2 U31-33
2-62-6374	IC 74AHCT16374 16-BIT DFF W/TRI-STATE OUTPUTS SOP-48	3	U4 U18 U20
2-62-6541	IC 74AHCT16541 16-BIT BUFFER/DRIVER W/TRI OUTS SOP-48	3	U8 U14-15
2-62-8374	IC 74AHC16374 16-BIT D-FF W/TRI OUTS SSOP-48	1	U26
2-63-0032	IC 74AHCT32D QUAD 2-IN POS-OR SOP-14	1	U16
2-66-5160	IC DRAM 256K x 16 70nS FAST PAGE MODE SOJ-40	1	U22
2-67-1289	IC SRAM 256Kx16 15nS 3.3V TSOP-44	2	U6 U12
2-67-1290	IC SRAM 256Kx16 70nS 3.3V LOW-POWER TSOP-44	1	U17
2-70-5308	IC MPU COLDFIRE MCF5307B 90MHz (J20C MASK) SQFP-208	1	U36
2-71-0082	IC TL082 DUAL OPAMP SOP-8	1	U10
2-72-0339	IC LM339 ANALOG COMP SOP-14	1	U30
2-72-4051	IC CD4051 SINGLE 8-CHAN MUX SOIC-16	1	U21
2-75-1101	IC CONVERTER A/D 24-BIT AL1101 SOP-16	1	U11
2-75-1201	IC CONVERTER D/A 24-BIT AL1201 SOP-16	1	U9
2-75-7842	IC CONVERTER A/D ADS7842 4-CHAN 12-BIT SSOP-28	1	U27
2-79-1814	IC CONTROLLER RESET W/OVERRIDE DS1813-10 +5V SOT-23	1	U37
2-81-1642	IC 74FCT164245T 3.3V to 5V TRANSCEIVER 16-BIT SSOP-48	3	U5 U7 U25
3-02-0026	LED BLUE T1 3/4 NON-DIFFUSED VIEW-ANGLE=30°	1	D1
4-00-0002	JACK DIN 5-PIN MIDI PCB MOUNT 180° W/SHIELD	3	J1-2 J6
4-02-0006	JACK 1/4" MONO 5-PIN FEM MINI W/GRND LUG STRAIGHT	3	J3-5
4-14-0116	HEADER DIL 16-PIN 0.1" SHRD	2	J12 J15
4-14-2601	HEADER DIL 26-PIN 0.1" MALE	2	J11 J13
4-14-4000	HEADER DIL 40-PIN 0.1"	1	J8
4-14-6000	HEADER DIL 60-PIN 0.1"	1	J9
4-15-0004	HEADER SIL 4-PIN 0.1"	1	J10
4-15-0600	HEADER SIL 6-PIN 3.96mm MALE EXT-LOCKING	1	J14
5-00-0021	SCREW 4-40 x 3/8" PPZ	3	U28 U38 U41
5-01-0029	WASHER FLAT #4 ZINC 0.25"OD	3	U28 U38 U41
5-02-4402	NUT HEX 4-40	3	U28 U38 U41
5-03-0029	STANDOFF LED 90° NYLON BLACK	1	D1
5-04-0007	WASHER #4 SPLITLOCK	3	U28 U38 U41
5-04-0045	SPACER CRYSTAL 5x11.25x1mm (TQ-06 PIN-GOOD)	3	Install with M1-M3
7-01-0007	CRYSTAL 24 MHz	1	M1
7-01-0027	CRYSTAL 45 MHz PARALLEL 32pF HC-49	1	M2
7-01-0030	CRYSTAL 5 MHz 20pF HC-49	1	M3
7-05-0003	BATTERY 3V LITHIUM COIN-TYPE PCB-MNT 23mmOD 2.5mmTHK	1	B1
7-10-0026	CON 68-PIN MEM CARD	1	J7
7-20-0055	INDUCTOR 470nH 0805 5%	1	L1
9-03-1132	HEATSINK	1	U38
9-40-0193-C	PCB MAIN A6 - REV C	1	
9-61-0038	IC PLD X4V012 C/S:05A0 9/22/00 A6	1	U29

A6-UL BOM
2002-09-18

9-61-0061	IC FLASH IMAGE V1.33 (BOOT=V1.20.37/OS=V1.40.12) C/S:0X2B59 4/12/02 A6	1	U3
2-69-6160	IC FLASH-ROM 1024Kx16 90nS TSOP-48	1	
7-53-0198	STICKER FLASH IMAGE V1.33 A6	1	
9-60-0061	SOFTWARE IMAGE V1.33 (BOOT=V1.20.37/OS=V1.40.12) C/S:0X2B59 4/12/02 A6	1	
9-79-0205	ASSY PCB ANALOG MASTER A6	1	
0-15-0105	RES 1M OHM 1/10W 5% 0805	3	R150 R158 R191
0-16-1000	RES 100 OHM 1/10W 1% 0805	20	R5-8 R50 R73 R108-109 R131 R134 R164-165 R178-179 R194-198 R207
0-16-1001	RES 1.00K OHM 1/10W 1% 0805	43	R1-4 R30-45 R55-56 R62-63 R87-90 R94 R107 R112-119 R147 R159 R168 R171 R183
0-16-1002	RES 10.0K OHM 1/10W 1% 0805	32	R26 R29 R46-49 R51 R53-54 R57 R59-60 R78 R91- 93 R122 R132-133 R146 R185 R200 R201 R202- 203 R204 R205-206 R229-230 R232 R234
0-16-1003	RES 100K OHM 1/10W 1% 0805	27	R9-20 R79-86 R95 R106 R135 R141 R167 R176 R236
0-16-1212	RES 12.1K OHM 1/10W 1% 0805	1	R155
0-16-1213	RES 121K OHM 1/10W 1% 0805	1	R237
0-16-1502	RES 15.0K OHM 1/10W 1% 0805	1	R177
0-16-2001	RES 2.00K OHM 1/10W 1% 0805	4	R76-77 R96 R105
0-16-2002	RES 20.0K OHM 1/10W 1% 0805	25	R52 R74-75 R120-121 R142-143 R148-149 R151- 152 R157 R170 R174 R182 R199 R208-210 R227- 228 R231 R233 R235 R238
0-16-2211	RES 2.21K OHM 1/10W 1% 0805	1	R163
0-16-2430	RES 243 OHM 1/10W 1% 0805	4	R21-24
0-16-2431	RES 2.43K OHM 1/10W 1% 0805	1	R169
0-16-2741	RES 2.74K OHM 1/10W 1% 0805	1	R161
0-16-3011	RES 3.01K OHM 1/10W 1% 0805	7	R25 R27-28 R58 R61 R156 R184
0-16-3013	RES 301K OHM 1/10W 1% 0805	1	R181
0-16-3322	RES 33.2K OHM 1/10W 1% 0805	4	R99 R102 R144 R186
0-16-4323	RES 432K OHM 1/10W 1% 0805	2	R154 R166
0-16-4750	RES 475 OHM 1/10W 1% 0805	3	R137-138 R153
0-16-4751	RES 4.75K OHM 1/10W 1% 0805	11	R98 R100-101 R103 R172-173 R175 R187-190
0-16-4752	RES 47.5K OHM 1/10W 1% 0805	33	R64-71 R123-130 R140 R211-226
0-16-4753	RES 475K OHM 1/10W 1% 0805	1	R72
0-16-5111	RES 5.11K OHM 1/10W 1% 0805	4	R136 R139 R160 R162
0-16-6193	RES 619K OHM 1/10W 1% 0805	2	R97 R104
0-16-6812	RES 68.1K OHM 1/10W 1% 0805	1	R180
0-16-8251	RES 8.25K OHM 1/10W 1% 0805	4	R110-111 R192-193
0-16-9091	RES 9.09K OHM 1/10W 1% 0805	1	R145
1-07-1474	CAP 0.47uF ELEC 50V 2x5x11mm	3	C174 C180 C222
1-11-0105	CAP 1.0uF ELEC 50V 2x5x11mm	1	C145
1-12-0471	CAP 4.7uF ELEC 63V 2x5x11mm	3	C159 C167 C217
1-12-0472	CAP 47uF ELEC 20% 63V 2.5x6.3x11mm	43	C1 C29-33 C36 C40 C42-43 C45-46 C48-49 C51 C54-57 C81 C96-99 C101-102 C104-105 C107-108 C110 C114 C137 C149 C152 C161 C175 C186 C189 C196-197 C202 C209
1-55-0222	CAP 2200pF NPO 0805 50V	1	C185
1-55-0470	CAP 47pF NPO 0805 50V	23	C52-53 C63-64 C66-67 C86-87 C123-124 C134-135 C150-151 C163 C177 C203-204 C206-208 C213- 214
1-55-0680	CAP 68pF NPO 0805	3	C176 C187-188
1-56-0101	CAP 100pF NPO 0805 5% 50V	2	C160 C168
1-56-0102	CAP 1000pF NPO 0805 5% 100V	30	C2-28 C165 C169 C201
1-56-0103	CAP 0.01uF X7R 0805	1	C193

A6-UL BOM
2002-09-18

			C34-35 C37-39 C41 C44 C47 C50 C58-61 C65 C68 C70-72 C82-85 C88-95 C100 C103 C106 C109 C111-113 C115-122 C136 C138-144 C146-148 C153-154 C156-158 C166 C170-173 C178-179 C181-183 C190-191 C195 C198-200 C205 C212 C215-216 C218-221
1-56-0104	CAP 0.1uF X7R 0805 10% 50V	85	
1-56-0220	CAP 22pF NPO 0805 5% 50V	16	C73-80 C126-133
1-56-0223	CAP 0.022uF X7R 0805 10% 50V	3	C155 C164 C194
1-56-0224	CAP 0.22uF X7R 0805 10% 16V	2	C125 C184
1-56-0332	CAP 3300pF X7R 0805 10% 50V	2	C162 C192
1-56-0474	CAP 0.47uF X7R 0805 16V	2	C62 C69
2-02-5237	DIODE ZENER 1N5237B 8.2V 1/2W DO-35	1	D9
2-05-0111	TRANS N-CHAN FET J111 35V 50mA TO-92	4	Q1-4
2-05-5458	TRANS J-FET N-CHAN 2N5458 25V TO-92	1	Q9
2-13-7906	REG VOLTAGE LM79L05 -5V TO-92	1	U22
2-50-4148	DIODE SIGNAL LS4148 MELF	13	D1-8 D10 D11-14
2-51-4401	TRANS NPN 2N4401 40V 1A SOT-23	5	Q6-8 Q10-11
2-51-4403	TRANS PNP 2N4403 40V 800mA SOT-23	1	Q5
2-71-0082	IC TL082 DUAL OPAMP SOP-8	20	U2-3 U6-10 U13-17 U21 U23-25 U27 U31-33
2-71-0912	IC TS912 DUAL OP-AMP CMOS RAIL-TO-RAIL SOP-8	6	U1 U18 U26 U28 U29-30
2-71-4580	IC NJM4580E DUAL AUDIO OP-AMP SOP-8	2	U4-5
2-72-0339	IC LM339 ANALOG COMP SOP-14	1	U12
2-72-4051	IC CD4051 SINGLE 8-CHAN MUX SOIC-16	1	U20
2-73-4053	IC CD4053 TRIPLE 2-CHAN ANALOG MUX/DEMUX SOIC-16	2	U11 U19
4-02-0007	JACK 1/4" STEREO 7-PIN FEM MINI W/GRND LUG STRAIGHT	18	J1-18
4-14-0050	HEADER DIL 50-PIN 0.1"	1	J21
4-14-2601	HEADER DIL 26-PIN 0.1" MALE	1	J20
4-15-1008	HEADER SIL 8-PIN 2mm SHRD	1	J19
9-40-0205-D	PCB ANALOG MASTER A6 - REV D	1	
9-79-0206	ASSY PCB FRONT-PANEL LEFT A6	1	
0-09-0018	POT 5KB DUAL 12mm D-SHAFT 17.5mm B-TAPER	2	R5 R14
0-09-0021	POT 10KA DUAL 12mm D-SHAFT 17.5mm	1	R9
0-09-1096	POT 5KB SINGLE 9mm D-SHAFT 17.5mm	16	R1-4 R6-8 R10-13 R15-19
0-15-0000	RES 0 OHM 1/10W 5% 0805	4	R33-34 R38-39
0-16-1000	RES 100 OHM 1/10W 1% 0805	7	R23 R26 R30 R32 R40 R66 R77
0-16-1001	RES 1.00K OHM 1/10W 1% 0805	3	R28-29 R42
0-16-1002	RES 10.0K OHM 1/10W 1% 0805	5	R48 R64-65 R75-76
0-16-1003	RES 100K OHM 1/10W 1% 0805	5	R27 R78-81
0-16-2210	RES 221 OHM 1/10W 1% 0805	20	R43-44 R46-47 R49-56 R58-59 R62-63 R67-68 R70-71
0-16-4751	RES 4.75K OHM 1/10W 1% 0805	14	R20-22 R45 R57 R60-61 R69 R72-74 R82-84
0-16-5112	RES 51.1k OHM 1/10W 1% 0805	2	R36-37
1-08-0476	CAP 47uF ELEC 25V 2.5x6.3x7mm	3	C7-8 C10
1-10-1102	CAP 10uF ELEC 50V 2x5x7mm	7	C1-6 C9
1-56-0102	CAP 1000pF NPO 0805 5% 100V	1	C23
1-56-0103	CAP 0.01uF X7R 0805	71	C11-22 C25-26 C28-36 C38-47 C53-86 C87-88 C89-90
1-56-0220	CAP 22pF NPO 0805 5% 50V	4	C49-52
1-56-0471	CAP 470pF CER X7R 0805 50V	1	C27
2-00-4148	DIODE SIGNAL 1N4148 75V 200mA	58	D9 D17-18 D20-27 D30-32 D36-41 D43 D47-48 D52 D54-57 D62-63 D67-73 D75-77 D80-82 D84-86 D88-90 D94-95 D98 D102-103 D105-108
2-11-2940	REG VOLTAGE LM2940C 5V TO-220	1	U1
2-13-7906	REG VOLTAGE LM79L05 -5V TO-92	1	U4
2-51-4401	TRANS NPN 2N4401 40V 1A SOT-23	8	Q1-8
2-62-0000	IC 74AHC00 QUAD 2-IN POS NAND SOP-14	1	U9
2-62-0004	IC 74AHC04 HEX INVERTERS SOP-14	2	U8 U13

A6-UL BOM
2002-09-18

2-62-0138	IC 74AHC138 3-8 DECODER/DEMUX SOP-16	3	U12 U16-17
2-62-0573	IC 74AHC573 OCTAL D-FF SOP-20	1	U14
2-62-0574	IC 74AHC574 OCTAL D FF W/TRI-STATE OUTS SOP-20	1	U20
2-64-0574	IC 74HC574 OCTAL D-FF W/ TRI-STATE OUTS SOP-20	4	U19 U21-23
2-67-1285	IC SRAM 128K x 8 55ns SOP-32	1	U5
2-70-8754	IC MPU P87C52UBBB 33MHz OTP QFP-44	1	U18
2-71-0082	IC TL082 DUAL OPAMP SOP-8	4	U7 U15 U24 U26
2-72-4051	IC CD4051 SINGLE 8-CHAN MUX SOIC-16	5	U10-11 U25 U27-28
3-02-0013	LED YELLOW HLMP-1440 T1	1	D60
3-02-0021	LED GREEN HLMP-1540 T1	49	D1-8 D10-16 D19 D28-29 D33-35 D42 D44-46 D49-51 D53 D58-59 D61 D64-66 D74 D78-79 D83 D87 D91-93 D96-97 D99-101 D104
4-06-0028	SOCKET 28-PIN DIP 0.6"	1	U6
4-14-0012	HEADER DIL 12-PIN 0.1"	1	J6
4-14-0020	HEADER DIL 20-PIN 0.1"	1	J3
4-14-4000	HEADER DIL 40-PIN 0.1"	1	J1
4-14-6000	HEADER DIL 60-PIN 0.1"	1	J4
4-15-0404	HEADER SIL 4-PIN 0.1" 90DEG	1	J5
4-15-1008	HEADER SIL 8-PIN 2mm SHRD	1	J2
4-15-2106	HEADER SIL 6-PIN 2mm 90°	1	J7
5-03-0015	STANDOFF LED 6mm NYLON	50	D1-8 D10-16 D19 D28-29 D33-35 D42 D44-46 D49-51 D53 D58-61 D64-66 D74 D78-79 D83 D87 D91-93 D96-97 D99-101 D104
5-04-0045	SPACER CRYSTAL 5x11.25x1mm (TQ-06 PIN-GOOD)	1	Install with M1
6-02-0050	SWITCH TACT	46	S1-46
7-01-0028	CRYSTAL 30 MHz	1	M1
9-40-0206-D	PCB FRONT-PANEL LEFT A6 - REV D	1	
9-61-0021	IC EPROM FRONT-PANEL V1.0 C/S:39A3 11/10/00 A6	1	U6
2-19-0512	IC EPROM 27C512 120nS	1	U6
7-53-0169	STICKER EPROM FRONT-PANEL V1.0 A6	1	U6
9-60-0021	SOFTWARE FRONT-PANEL V1.0 C/S:39A3 11/10/00 A6	1	U6
9-79-0207	ASSY PCB FRONT-PANEL CENTER A6	1	
0-09-0018	POT 5KB DUAL 12mm D-SHAFT 17.5mm B-TAPER	2	R3 R19
0-09-1090	POT 10KB SINGLE 9mm SERRATED 20mm	1	R6
0-09-1096	POT 5KB SINGLE 9mm D-SHAFT 17.5mm	20	R1-2 R4-5 R7-18 R20-23
0-16-1000	RES 100 OHM 1/10W 1% 0805	1	R30
0-16-1001	RES 1.00K OHM 1/10W 1% 0805	4	R24 R28-29 R31
0-16-1003	RES 100K OHM 1/10W 1% 0805	1	R27
1-08-0476	CAP 47uF ELEC 25V 2.5x6.3x7mm	1	C20
1-10-1102	CAP 10uF ELEC 50V 2x5x7mm	4	C1-4
1-56-0103	CAP 0.01uF X7R 0805	33	C5-14 C16-19 C21-26 C28-40
1-56-0471	CAP 470pF CER X7R 0805 50V	1	C15
2-00-4148	DIODE SIGNAL 1N4148 75V 200mA	70	D3 D5-15 D27-30 D33 D38 D40-41 D45-46 D49 D51-52 D57-61 D65-67 D70-80 D91-116
2-62-0138	IC 74AHC138 3-8 DECODER/DEMUX SOP-16	1	U6
2-71-0082	IC TL082 DUAL OPAMP SOP-8	1	U4
2-72-4051	IC CD4051 SINGLE 8-CHAN MUX SOIC-16	3	U3 U5 U7
3-02-0013	LED YELLOW HLMP-1440 T1	3	D39 D48 D55
3-02-0021	LED GREEN HLMP-1540 T1	43	D1-2 D4 D16-26 D31-32 D34-37 D42-44 D47 D50 D53-54 D56 D62-64 D68-69 D81-90
4-14-6000	HEADER DIL 60-PIN 0.1"	1	J1
5-03-0015	STANDOFF LED 6mm NYLON	46	D1-2 D4 D16-26 D31-32 D34-37 D39 D42-44 D47-48 D50 D53-56 D62-64 D68-69 D81-90
6-02-0050	SWITCH TACT	70	S1-70
9-40-0207-D	PCB FRONT-PANEL CENTER A6 - REV D	1	
9-79-0208	ASSY PCB FRONT-PANEL RIGHT A6	1	
0-09-1096	POT 5KB SINGLE 9mm D-SHAFT 17.5mm	31	R1-31

A6-UL BOM
2002-09-18

0-16-1000	RES 100 OHM 1/10W 1% 0805	1	R35
0-16-1001	RES 1.00K OHM 1/10W 1% 0805	2	R33-34
0-16-1003	RES 100K OHM 1/10W 1% 0805	1	R32
1-10-1102	CAP 10uF ELEC 50V 2x5x7mm	4	C1-4
1-56-0103	CAP 0.01uF X7R 0805	41	C5-15 C17-22 C24-27 C29-48
1-56-0471	CAP 470pF CER X7R 0805 50V	1	C16
2-00-4148	DIODE SIGNAL 1N4148 75V 200mA	45	D8-14 D16 D18 D24 D27-28 D36-42 D49-50 D52 D61-68 D70 D79-82 D84-85 D87-93 D95
2-62-0138	IC 74AHC138 3-8 DECODER/DEMUX SOP-16	1	U8
2-71-0082	IC TL082 DUAL OPAMP SOP-8	1	U5
2-72-4051	IC CD4051 SINGLE 8-CHAN MUX SOIC-16	4	U3-4 U6-7
3-02-0013	LED YELLOW HLMP-1440 T1	1	D51
3-02-0021	LED GREEN HLMP-1540 T1	49	D1-7 D15 D17 D19-23 D25-26 D29-35 D43-48 D53- 60 D69 D71-78 D83 D86 D94
4-14-6000	HEADER DIL 60-PIN 0.1"	1	J1
5-03-0015	STANDOFF LED 6mm NYLON	50	D1-7 D15 D17 D19-23 D25-26 D29-35 D43-48 D51 D53-60 D69 D71-78 D83 D86 D94
6-02-0050	SWITCH TACT	45	S1-45
9-40-0208-C	PCB FRONT-PANEL RIGHT A6 - REV C	1	
9-79-0210	ASSY PCB ANALOG ASIC A6	1	
0-15-0000	RES 0 OHM 1/10W 5% 0805	16	R57-60 R73 R76 R79 R82 R90 R93 R96 R99 R108- 111
0-16-1000	RES 100 OHM 1/10W 1% 0805	18	R49-56 R70-71 R115 R118 R121 R124 R127 R130 R133 R136
0-16-1001	RES 1.00K OHM 1/10W 1% 0805	4	R6 R8 R10 R12
0-16-1002	RES 10.0K OHM 1/10W 1% 0805	1	R139
0-16-1009	RES 10.0 OHM 1/10W 1% 0805	8	R1-4 R14 R16 R18 R20
0-16-1211	RES 1.21K OHM 1/10W 1% 0805	1	R138
0-16-1301	RES 1.30K OHM 1/10W 1% 0805	8	R13 R15 R17 R19 R31 R36 R41 R46 R74-75 R77-78 R80-81 R83-84 R87-89 R91-92 R94- 95 R98
0-16-2002	RES 20.0K OHM 1/10W 1% 0805	16	R21-R28
0-16-2211	RES 2.21K OHM 1/10W 1% 0805	8	R5 R9 R11 R57
0-16-3011	RES 3.01K OHM 1/10W 1% 0805	4	R137
0-16-4750	RES 475 OHM 1/10W 1% 0805	1	R61-69 R86 R97 R100-107
0-16-4752	RES 47.5K OHM 1/10W 1% 0805	19	R72 R85 R112
0-16-6812	RES 68.1K OHM 1/10W 1% 0805	3	
0-17-0100	RES CHIP ARRAY 4x10 OHM 1/10W 5% ISOLATED C- C=1.27	16	R146-161
0-17-1333	RES CHIP ARRAY 4 x 33K OHM 1/10W 5% ISOLATED c- c=1.27mm	32	R29-30 R32-35 R37-40 R42-45 R47-48 R113-114 R116-117 R119-120 R122-123 R125-126 R128-129 R131-132 R134-135
1-12-0472	CAP 47uF ELEC 20% 63V 2.5x6.3x11mm	25	C85 C216 C223-225 C227-232 C237-243 C248 C253 C258 C263 C286 C413 C416 C94-95 C97-98 C100-101 C103-C104 C106-107 C110-111 C114-115 C118-119 C154-155 C158-159 C162-163 C166-167 C170-171 C174-175 C178-179 C182-183 C289-290 C293-294 C297-298 C301-302 C306-307 C310-311 C314-315 C318-319 C354-355 C358-359 C362-363 C366-367 C369-370 C372-373 C375-376 C378-379
1-55-0391	CAP 390pF NPO 0805 5% 50V	64	C37 C40 C43 C46
1-55-0680	CAP 68pF NPO 0805	4	C24-27 C39 C42 C45 C48 C57 C61 C64 C68 C71 C75 C78 C82 C391 C394 C397 C400 C403 C406 C409 C412 C420
1-56-0102	CAP 1000pF NPO 0805 5% 100V	25	

A6-UL BOM
2002-09-18

1-56-0103	CAP 0.01uF X7R 0805	69	C14-17 C140 C144 C148 C152 C156-157 C160-161 C164-165 C168-169 C172-173 C176-177 C180-181 C184-185 C188-189 C192-193 C196-197 C200-201 C203 C205 C207 C209 C264-269 C272-273 C276- 277 C280-281 C287-288 C291-292 C295-296 C299- 300 C304-305 C308-309 C312-313 C316-317 C321 C325 C329 C333 C419
1-56-0104	CAP 0.1uF X7R 0805 10% 50V	184	C2 C4 C6 C8-13 C18-23 C38 C41 C44 C47 C49 C51 C53 C55 C58-60 C62-63 C65-67 C69-70 C72- 74 C76-77 C79-81 C83-84 C86-93 C96 C99 C102 C105 C109 C113 C117 C121-123 C126-127 C130- 131 C134-135 C138-139 C142-143 C146-147 C150- 151 C186-187 C190-191 C194-195 C198-199 C202 C204 C206 C208 C210-215 C217-222 C226 C233- 236 C244-247 C249-252 C254-257 C259-262 C270- 271 C274-275 C278-279 C282-285 C303 C322-323 C326-327 C330-331 C334-335 C338-339 C342-343 C346-347 C350-352 C356 C360 C364 C368 C371 C374 C377 C380-390 C392-393 C395-396 C398- 399 C401-402 C404-405 C407-408 C410-411 C414- 415 C417-418
1-56-0220	CAP 22pF NPO 0805 5% 50V	9	C1 C3 C5 C7 C28 C50 C52 C54 C56
1-56-0331	CAP 330pF NPO 0805 5% 50V	32	C108 C112 C116 C120 C124-125 C128-129 C132- 133 C136-137 C141 C145 C149 C153 C320 C324 C328 C332 C336-337 C340-341 C344-345 C348- 349 C353 C357 C361 C365
1-71-0105	CAP 1.0uF TANT-B 35V SMD-B	8	C29-36
2-05-0111	TRANS N-CHAN FET J111 35V 50mA TO-92	1	Q1
2-11-2940	REG VOLTAGE LM2940C 5V TO-220	1	U25
2-11-7812	REG VOLTAGE LM7812 +12V TO-220	1	U35
2-11-7912	REG VOLTAGE LM7912 -12V TO-220	1	U24
2-25-0054	IC PCM54 16-BIT DAC DIP-28	4	U6-9
2-27-0058	ASIC ASF (TESTED) A6	8	U16 U18 U20 U22 U26 U28 U30 U32
2-27-0059	ASIC ASO (TESTED) A6	8	U15 U17 U19 U21 U27 U29 U31 U33
2-50-4148	DIODE SIGNAL LS4148 MELF	4	D5-8
2-51-4403	TRANS PNP 2N4403 40V 800mA SOT-23	1	Q2
2-62-0138	IC 74AHC138 3-8 DECODER/DEMUX SOP-16	1	U10
2-62-6374	IC 74AHCT16374 16-BIT DFF W/TRI-STATE OUTPUTS SOP-48	4	U1-4
2-71-0082	IC TL082 DUAL OPAMP SOP-8	1	U36
2-71-0912	IC TS912 DUAL OP-AMP CMOS RAIL-TO-RAIL SOP-8	1	U23
2-71-2134	IC OPA2134 DUAL OP-AMP SOIC-8	4	U11-14
2-73-4053	IC CD4053 TRIPLE 2-CHAN ANALOG MUX/DEMUX SOIC-16	1	U34
4-14-0050	HEADER DIL 50-PIN 0.1"	1	J2
4-14-6000	HEADER DIL 60-PIN 0.1"	1	J1
5-00-0106	SCREW M3 x 8mm PPZ w/NYLOC PATCH	3	U24-25 U35
5-02-0009	HEATSINK M3 x 20	3	U24-25 U35
5-04-0009	WASHER M3 SPLITLOCK	3	U24-25 U35
9-40-0210-D	PCB ANALOG ASIC A6 - REV D	1	
9-79-BA02	ASSY PCB POWER SUPPLY A6	1	
0-01-1000	RES 100 OHM 1/8W 1%	1	R22
0-01-1001	RES 1.00K OHM 1/8W 1%	2	R7 R11
0-01-1002	RES 10.0K OHM 1/8W 1%	3	R8 R26 R27
0-01-1003	RES 100K OHM 1/8 1%	3	R18 R23 R28
0-01-1009	RES 10.0 OHM 1/8W 1%	1	R4
0-01-1502	RES 15.0K OHM 1/8W 1%	2	R5 R12
0-01-1503	RES 150K OHM 1/8W 1%	2	R1-2

A6-UL BOM
2002-09-18

0-01-1821	RES 1.82K OHM 1/8W 1%	1	R16
0-01-2612	RES 26.1K OHM 1/8W 1%	1	R19
0-01-2741	RES 2.74K OHM 1/8W 1%	1	R10
0-01-3652	RES 36.5K OHM 1/8W 1%	1	R17
0-01-4759	RES 47.5 OHM 1/8W 1%	1	R21
0-01-7501	RES 7.50K OHM 1/8W 1%	1	R6
0-01-8251	RES 8.25K OHM 1/8W 1%	1	R20
0-04-1000	RES 100 OHM 1/4W 1%	1	R9
0-04-2009	RES 20.0 OHM 1/4W 1%	1	R25
0-05-1338	RES .33 OHM 1W 5%	1	R13
0-05-2124	RES 120K OHM 2W 5%	1	R3
0-05-2271	RES 270 OHM 2W 5%	1	R15
0-05-2393	RES 39K OHM 2W 5%	1	R14
0-21-4751	RES 4.75K OHM 1W 1%	1	R24
0-22-0100	THERMISTOR 10 OHM 2A NTC	1	RT1
1-02-0103	CAP 0.01uF CERDISC Y5P 10% 50V 5.12x9x3mm	2	C14 C25
1-02-0104	CAP 0.1uF CERDISC 10% .30"DIA.	1	C24
1-02-0223	CAP 0.022uF CERDISC 10% 50V Z5U 5x9x2mm	1	C13
1-02-0471	CAP 470pF CERDISC Y5P 10% 50V	1	C21
1-02-4713	CAP 470pF CERDISC Y5F 20% 1KV 5x5x3mm	1	C10
1-02-5103	CAP 0.01uF CERDISC 20% 500V 5x5x2mm	1	C8
1-02-9222	CAP 220pF CERDISC 20% 1KV 5x8x3mm	1	C9
1-13-0103	CAP 100uF ELEC 400V 10x26x26mm	1	C6
1-14-0100	CAP 0.1uF X2-CAP +/-20% 250VAC 15x18x8.5x14.5mm	2	C1-2
1-15-2102	CAP 1000pF Y-CAP 250VAC 5x6.5x4.5mm	3	C3-5
1-16-0224	CAP 2200uF ELEC LOW-ESR 10V 105øC 5x12.5x25mm	2	C17-18
1-16-0472	CAP 47uF ELEC LOW-ESR 35V 105øC 2.5x6.3x11mm	1	C7
1-16-0683	CAP 680uF ELEC LOW-ESR 35V 105øC 5x12.5x25mm	4	C15-16, C19-20
1-20-0472	CAP 4700pF FILM 5% 100V	1	C11
1-21-0104	CAP 0.1uF MONO 20% 50V RADIAL	1	C12
2-01-0666	DIODE POWER SCHOTTKY 45V 10A TO-220	1	D8
2-01-2220	DIODE POWER ULTRA-FAST MUR820 200V 8A TO-220	2	D7, D9
2-01-4007	DIODE POWER 1N4007 1000V 1A	4	D1-4
2-02-0600	DIODE POWER ULTRAFast MUR160 600V 1A	1	D6
2-02-5237	DIODE ZENER 1N5237B 8.2V 1/2W DO-35	1	D10
2-02-5245	DIODE ZENER 1N5245B 15V 1/2W DO-35	1	D12
2-03-4401	TRANS NPN GEN-PURPOSE-AMP 2N4401 40V 1A TO-92	1	Q3
2-03-4403	TRANS PNP 2N4403 40V 600mA TO-92	1	Q4
2-05-0040	TRANS POWER N-CHAN FET 600V 6.2A TO-220	1	Q1
2-06-0001	SCR 50V 8A TO-220	1	Q2
2-10-3844	IC MODULATOR UC3844N	1	U1
2-11-0431	REG ADJ-SHUNT TL431 2.5V-36V 100mA 2% TO-92	1	U3
2-24-8104	IC OPTO-ISOLATOR TCDDT1124 6-PIN	1	U2
2-99-0021	DIODE BAV21 SOD-27	3	D5 D11 D13
4-09-0010	CON PWR IEC 10A 250V PCB-MOUNT W/TOP GND LUG	1	J1
4-15-0200	HEADER SIL 2-PIN 3.96mm MALE EXT-LOCKING	1	J3
4-15-0600	HEADER SIL 6-PIN 3.96mm MALE EXT-LOCKING	1	J4
5-00-0021	SCREW 4-40 x 3/8" PPZ	4	D7-9, Q1
5-00-0036	SCREW M3 x 10mm PPZ	2	(2)IEC-PCB (3)STANDOFF
5-01-0029	WASHER FLAT #4 ZINC 0.25"OD	4	D7-9, Q1
5-01-0035	WASHER #4 SHOULDER NYLON .140 OD X .116 ID X .090 L	4	D7-9, Q1
5-02-4402	NUT HEX 4-40	4	D7-9, Q1
5-02-6328	NUT KEP M3 STEEL/ZINC	2	(2)IEC-PCB
5-04-0007	WASHER #4 SPLITLOCK	4	D7-9, Q1
5-05-1001	CLIP FUSE HOLDER 5 x 12mm	2	F1
7-04-0023	FUSE 2A 250V 5X20mm F UL-LISTED	1	
7-07-0023	INSULATOR POLY-PAD 400 TO-220	4	D7-9, Q1
7-07-0043	INSULATOR TUBING FRS 18AWG x 1" STANDARD WALL	1	R15

A6-UL BOM
2002-09-18

7-07-0044	INSULATOR TUBING FRS 18AWG x 7/8" STANDARD WALL	2	R3, R14
7-30-0011	CHOKE COMMON MODE 0.65A 10mH	1	L1
7-30-0012	CHOKE ROD OUTPUT 10uH 6A 1"-HIGH	3	L2-4
7-40-0029	TRANSFORMER FLYBACK ER28L HORIZ-MNT 12-PIN BA02	1	T1
7-52-0002	STICKER FUSE 2A/250V 0.8" DIA.	1	C6
9-03-0020	HEATSINK 66.5x25.0x25.0	2	HS1-2
9-40-BA01-H	PCB POWER SUPPLY BA01 - REV H	1	
9-96-0203	ASSY RIBBON CONTROLLER A6	1	
7-00-0010-D	FILM SENSOR RIBBON CONTROLLER A6	1	
7-12-0041	TAPE ADHESIVE-TRANSFER WIDTH=1.25"	21	
7-14-0037	COVER FABRIC RIBBON CONTROLLER A6	21	
9-03-1314-B	BRACKET CENTER SUPPORT A6 - REV B	1	
9-32-0004-A	RUBBER RIBBON-CONTROLLER A6 - REV A	1	
9-96-0204	ASSY PITCH/MOD BEZEL A6	1	
0-09-1106	POT 10KB SINGLE CONTROL EYELT 18mm-SHFT	2	
4-19-2000	CABLE SLIDER-TO-POT	1	
5-00-2308	SCREW M3 x 8mm PPZ PLAST	9	
7-13-0080	TUBING HEATSHRINK 1/16" DIA x 5/8" 300V 80c	1	
9-03-1310-A	BRACKET PITCH WHEEL A6 - REV A	1	
9-03-1311-A	BRACKET MOD WHEEL A6 - REV A	1	
9-06-0017-A	SPRING PITCH WHEEL A6	1	
9-06-0018-A	SPRING MOD WHEEL A6	1	
9-10-0037-C	BEZEL PITCH/MOD WHEEL A6 - REV C	1	
9-15-1225	LENS POWER/SIGNAL NANO-SERIES	4	
9-96-0064	ASSY WHEEL PITCH/MOD A6	2	INCLUDES (2)9-15-1370-C (1)9-32-0005-A
9-79-0204	ASSY PCB PITCH/MOD WHEEL A6	1	
2-00-4148	DIODE SIGNAL 1N4148 75V 200mA	4	D3-6
3-02-0021	LED GREEN HLMP-1540 T1	4	D1-2 D7-8
4-70-1205-B	CABLE RIBBON DIL 12-PIN 0.1" 50mm F-M Z-TYPE	1	J1
5-03-0018	STANDOFF LED 4mm NYLON	4	D1-2 D7-8
6-02-0050	SWITCH TACT	4	S1-4
9-40-0204-B	PCB PITCH/MOD WHEEL A6 - REV B	1	

ALESIS ANDROMEDA (A6)

SCHEMATIC FILES PCB FILES

6

5

4

3

2

1

REVISION RECORD			
LTR	ECC NO:	APPROVED:	DATE:

TO A6 DIG MAIN PCB

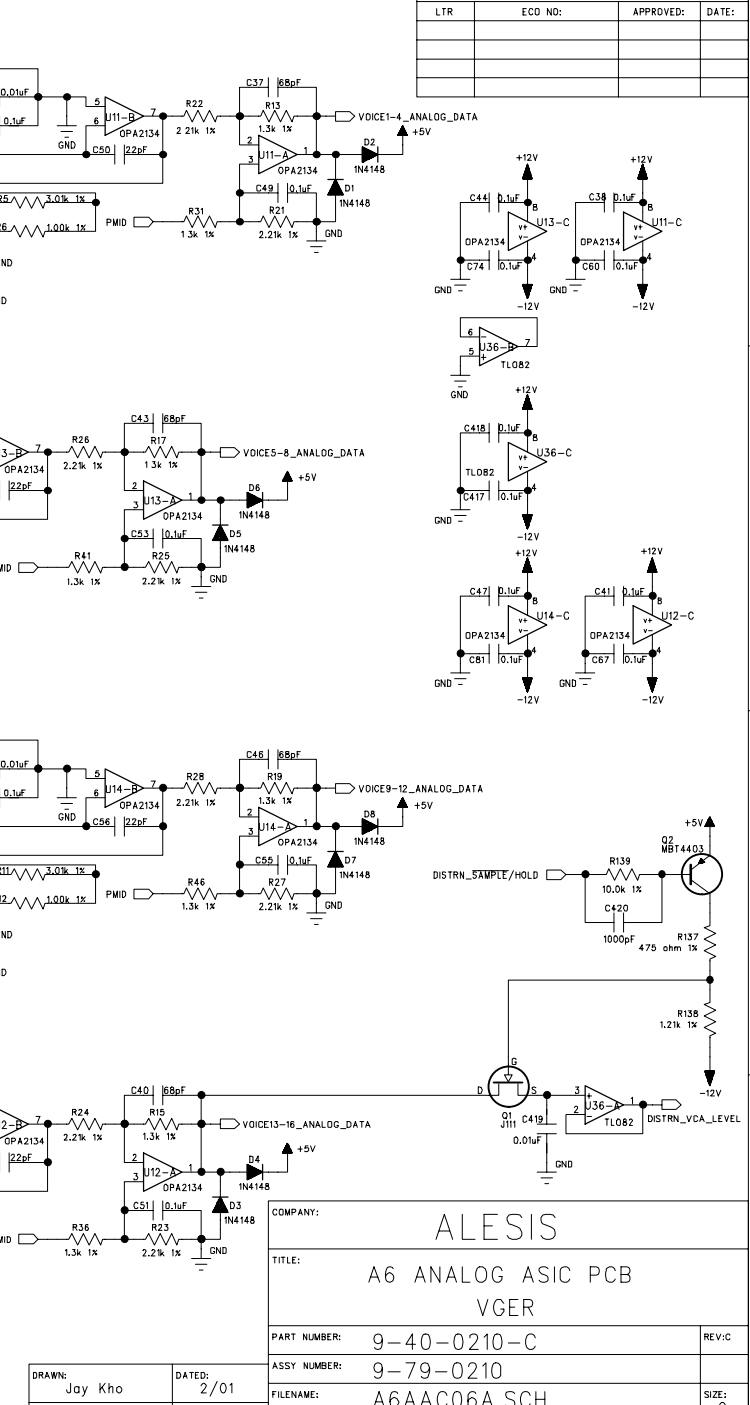
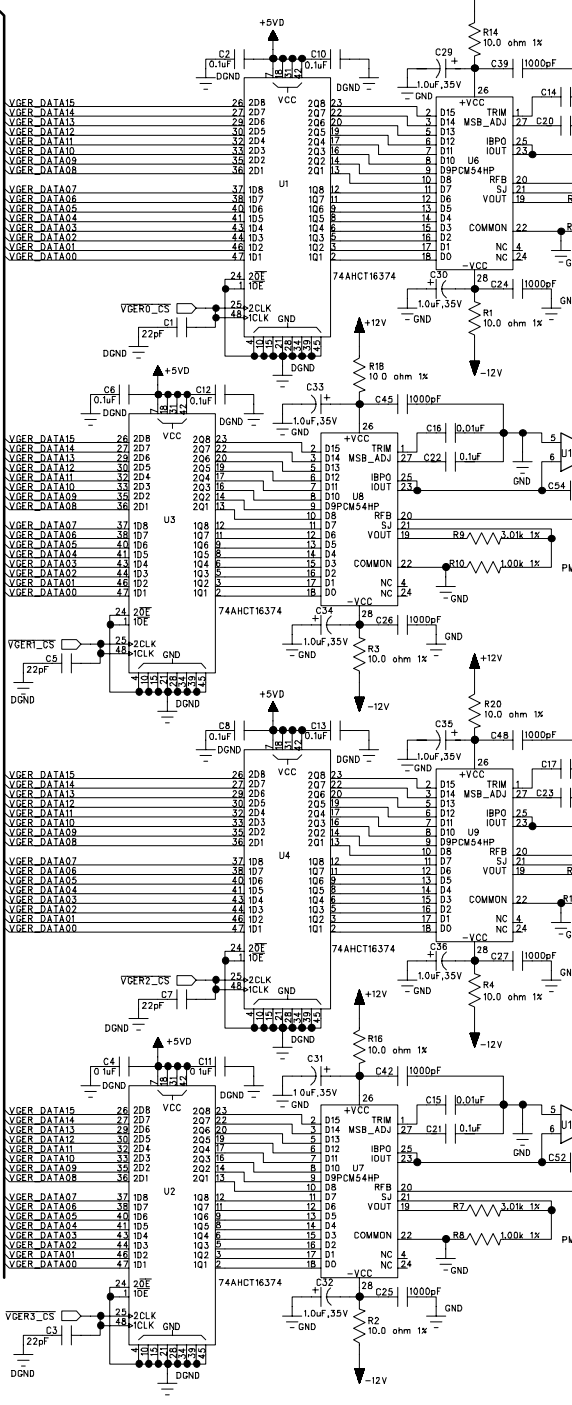
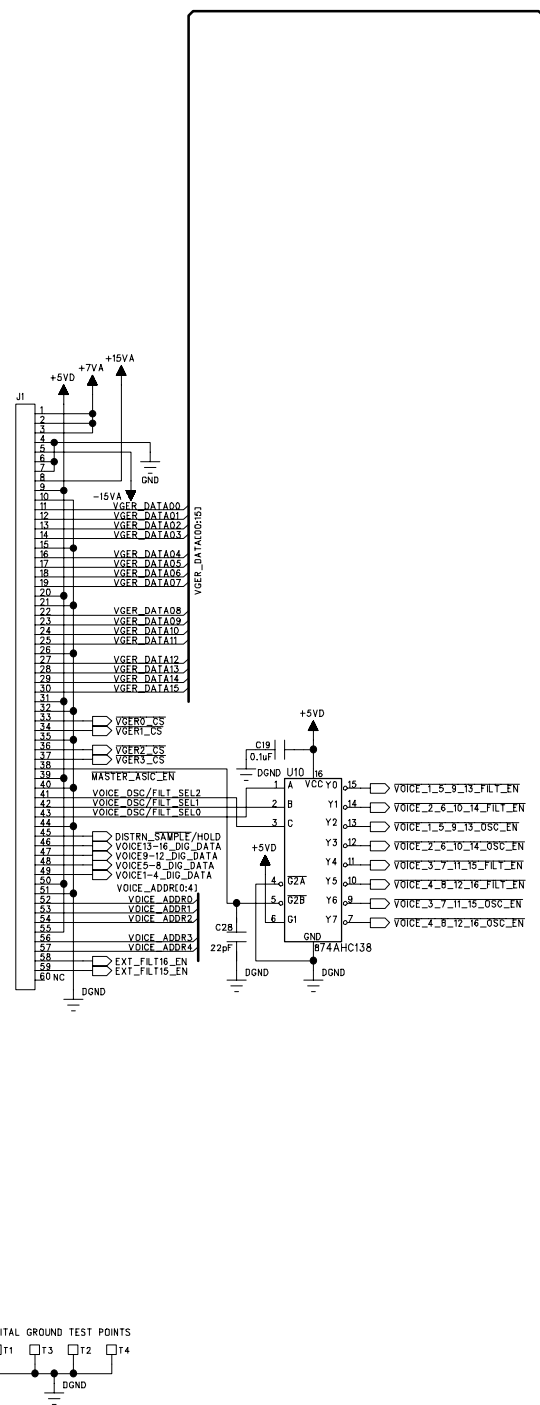
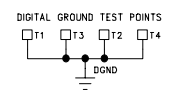

COMPANY: **ALESIS**

TITLE: **A6 ANALOG ASIC PCB**

VGER

PART NUMBER: **9-40-0210-C** REV: **C**

ASSY NUMBER: **9-79-0210**

FILENAME: **A6AAC06A.SCH** SIZE: **C**

SCALE: SHEET: **1** OF **6**

DRAWN: **Jay Kho** DATED: **2/01**

RELEASED: DATED:

6

5

4

3

2

1

REVISION RECORD			
LTR	ECC NO:	APPROVED:	DATE:

VOICE 1/2

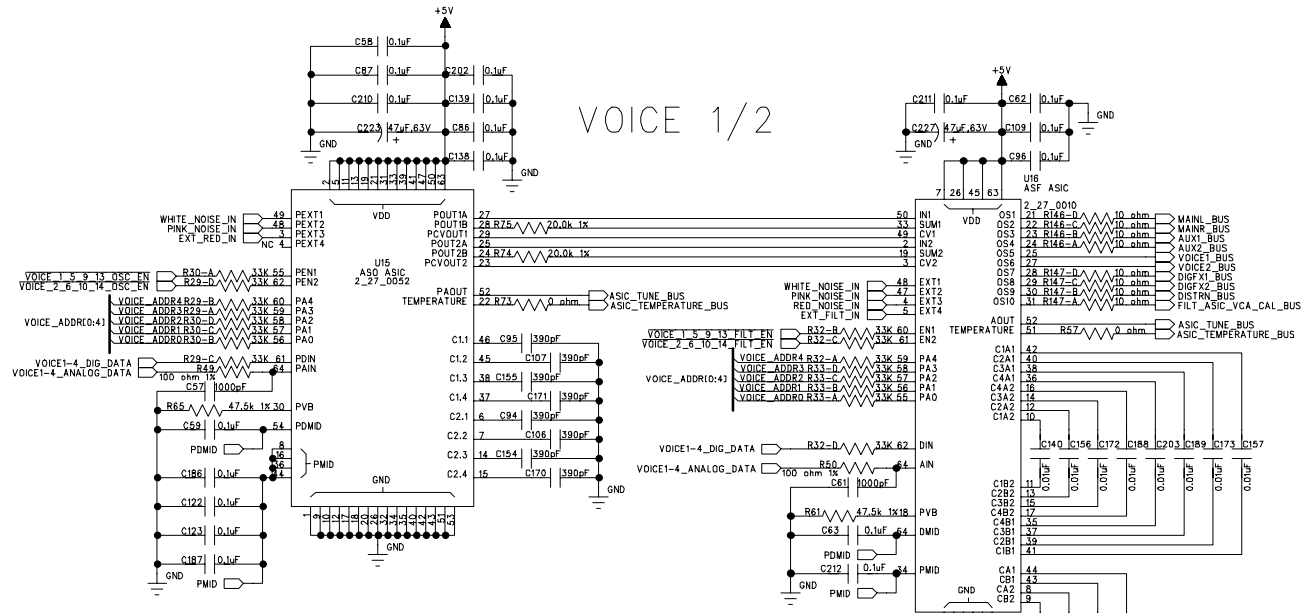

VOICE 3/4

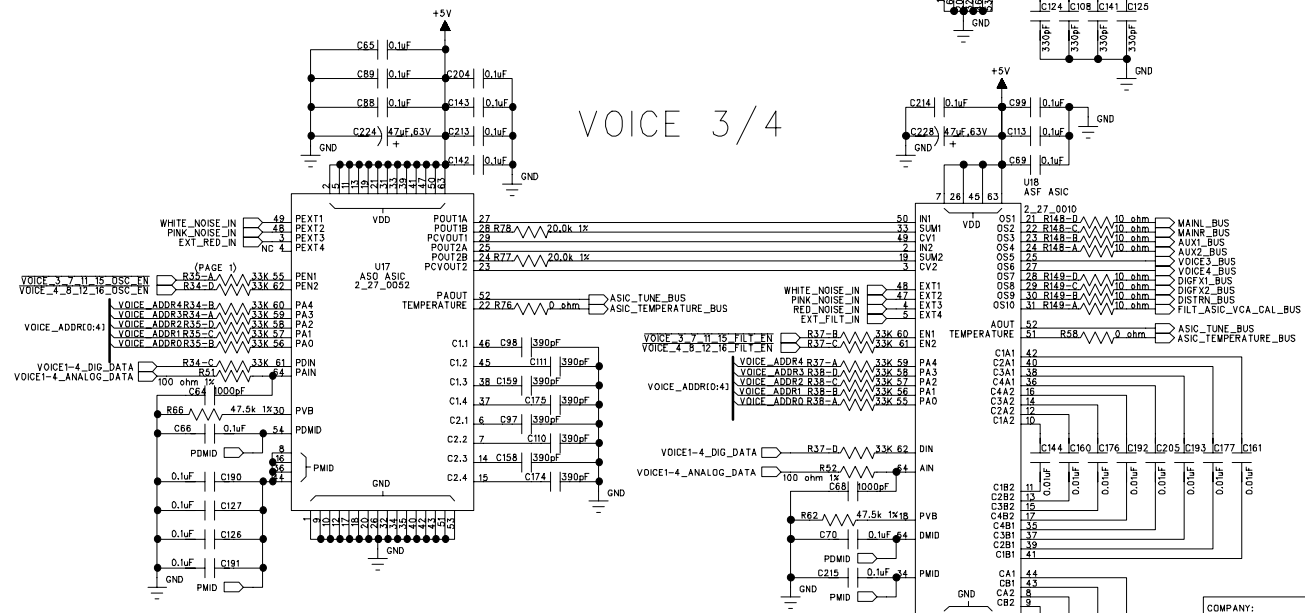

COMPANY: **ALESIS**

TITLE: **A6 ANALOG ASIC PCB VOICES 1-4**

PART NUMBER: 9-40-0210-C REV: C

ASSY NUMBER: 9-79-0210

FILENAME: A6AAC06A.SCH SIZE: C

SCALE: SHEET. 2 OF 6

DRAWN: Jay Kho DATED: 2/01

RELEASED: DATED:

REVISION RECORD			
LTR	ECC NO:	APPROVED:	DATE:

VOICE 5/6

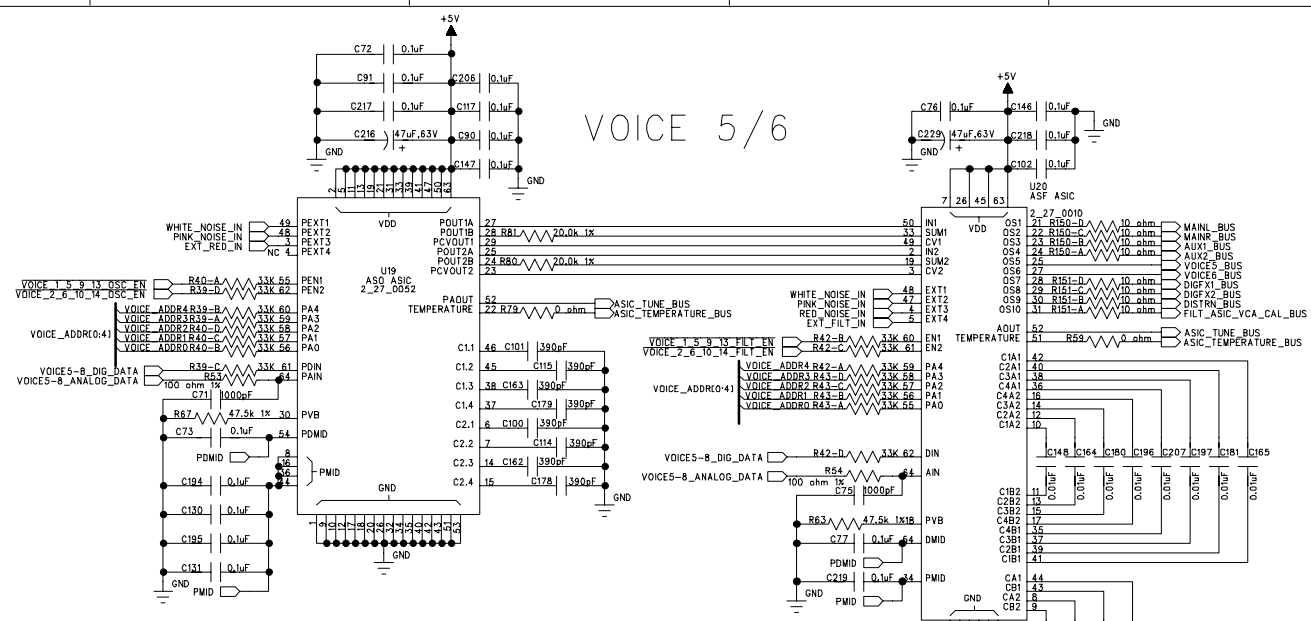

VOICE 7/8

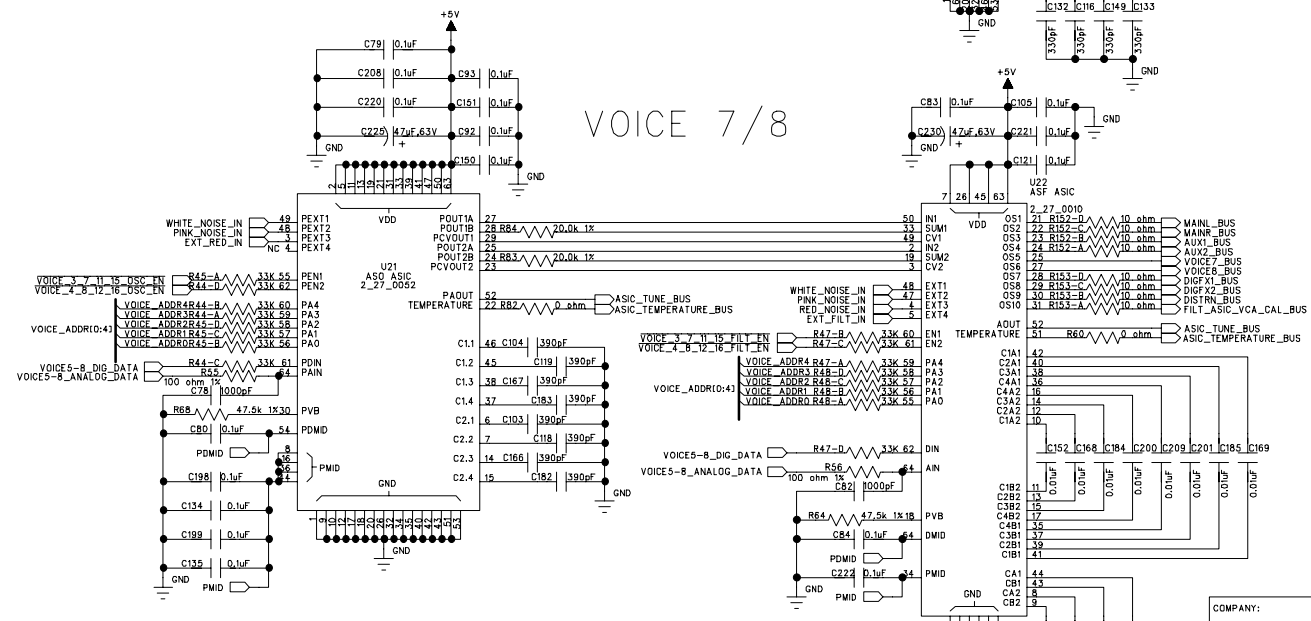

COMPANY:		ALESIS	
TITLE:		A6 ANALOG ASIC PCB VOICES 5-8	
PART NUMBER:	9-40-0210-C	REV:	C
ASSY NUMBER:	9-79-0210	FILENAME:	A6AAC06A.SCH
SCALE:		SHEET:	3 OF 6

DRAWN:	Jay Kho	DATED:	2/01
RELEASED:		DATED:	

REVISION RECORD			
LTR	ECC NO:	APPROVED:	DATE:

VOICE 9/10

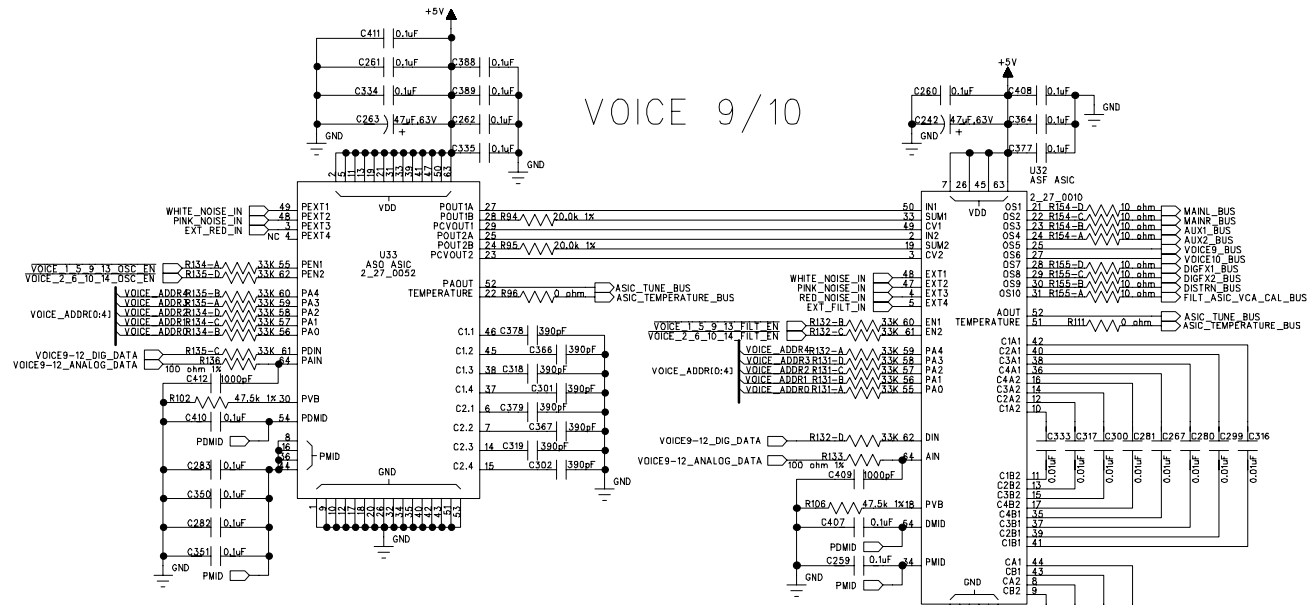

VOICE 11/12

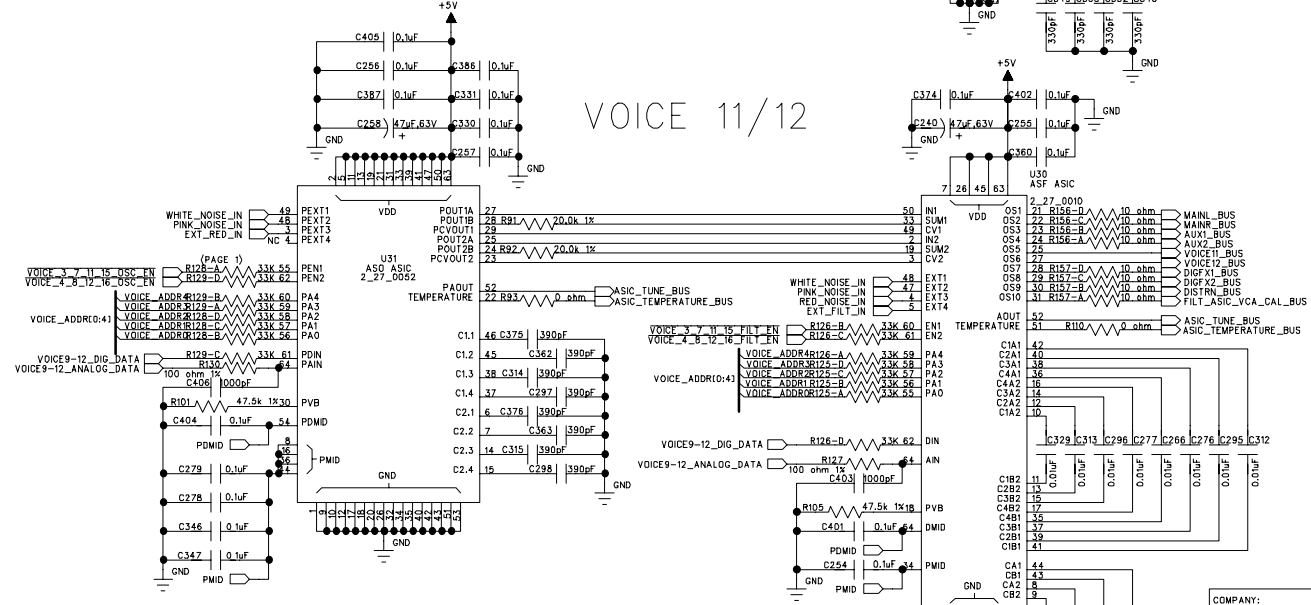

COMPANY:	ALESIS		
TITLE:	A6 ANALOG ASIC PCB VOICES 9-12		
PART NUMBER:	9-40-0210-C	REV:	C
ASSY NUMBER:	9-79-0210	FILENAME:	A6AAC06A.SCH
SCALE:	SHEET 4	OF	6

DRAWN:	Jay Kho	DATED:	2/01
RELEASED:		DATED:	

REVISION RECORD			
LTR	ECD NO:	APPROVED:	DATE:

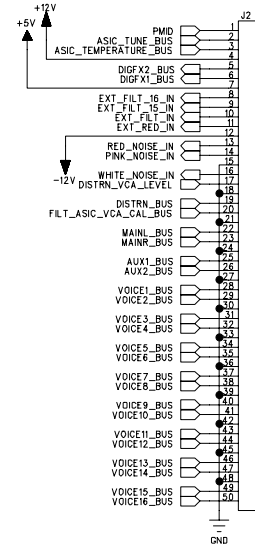
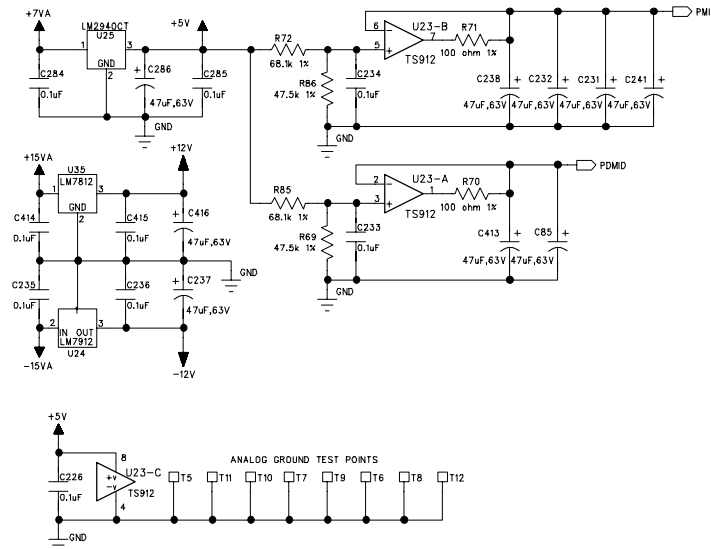

TO A6 ANALOG MASTER PCB

DRAWN: Jay Kho		DATED: 2/01		COMPANY: ALESIS	
RELEASED:		DATED:		TITLE: A6 ANALOG ASIC PCB MISCELLANEOUS	
PART NUMBER: 9-40-0210-C		REV: C		ASSY NUMBER: 9-79-0210	
FILENAME: A6AAC06A.SCH		SCALE:		SHEET: 6 OF 6	

ALESIS 9-40-0210-C "TOPASSY"

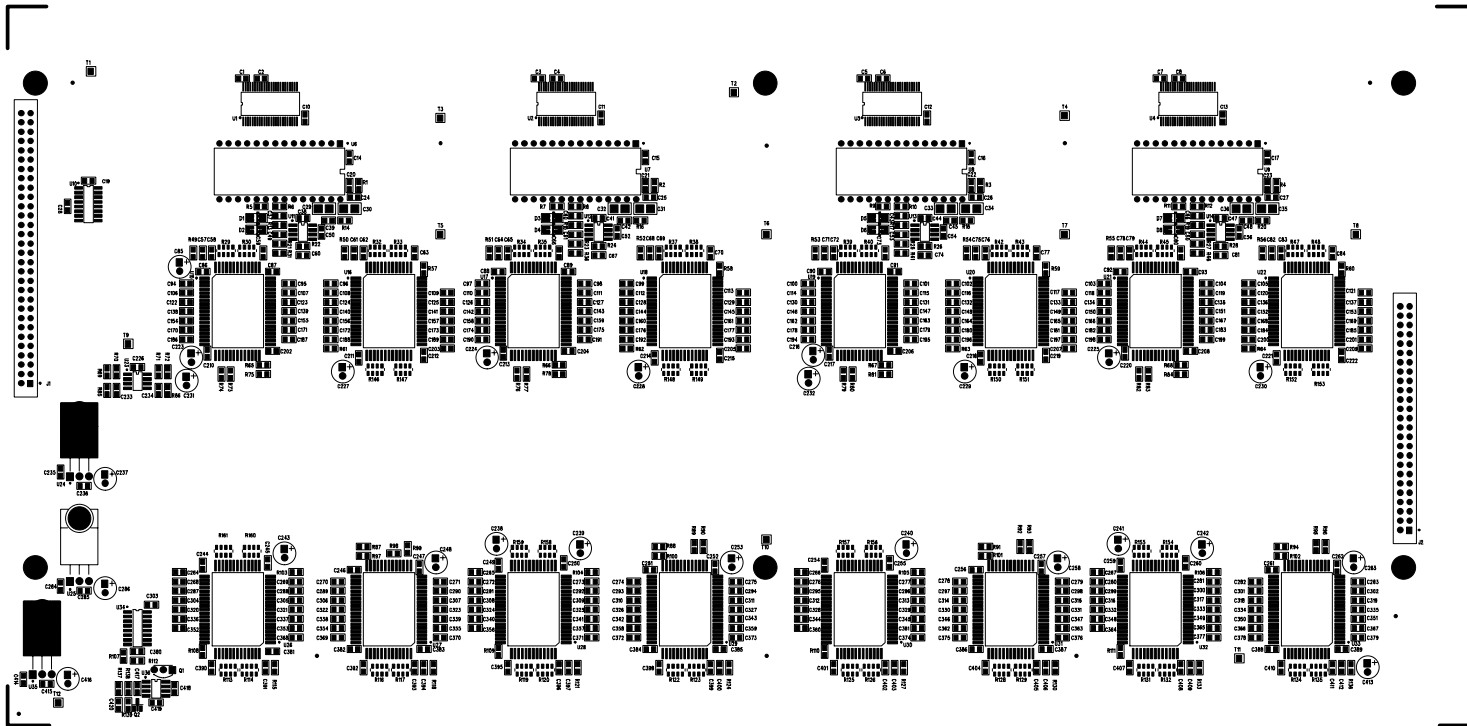

Mounting Instructions for U24, U25, and U35
(to be assembled before soldering).

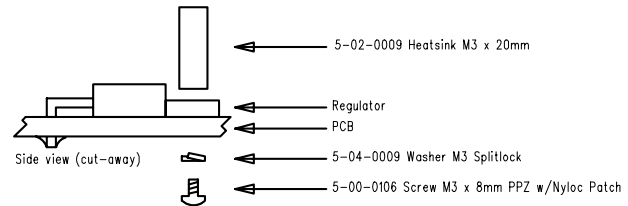



ALESIS 9-40-0210-C "TOPTRACE"

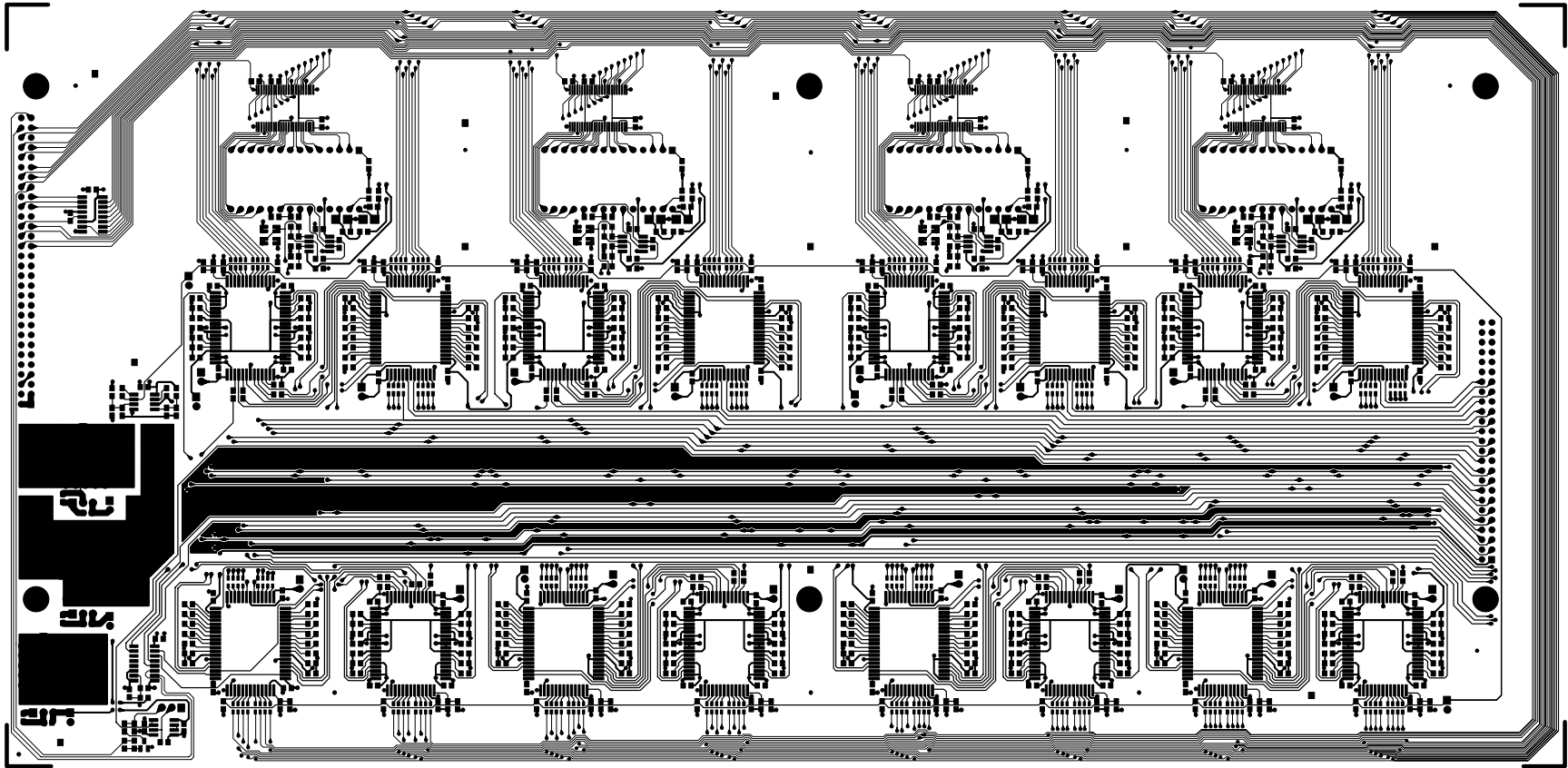



ALESIS 9-40-0210-C "GNDPLANE LAYER 2"

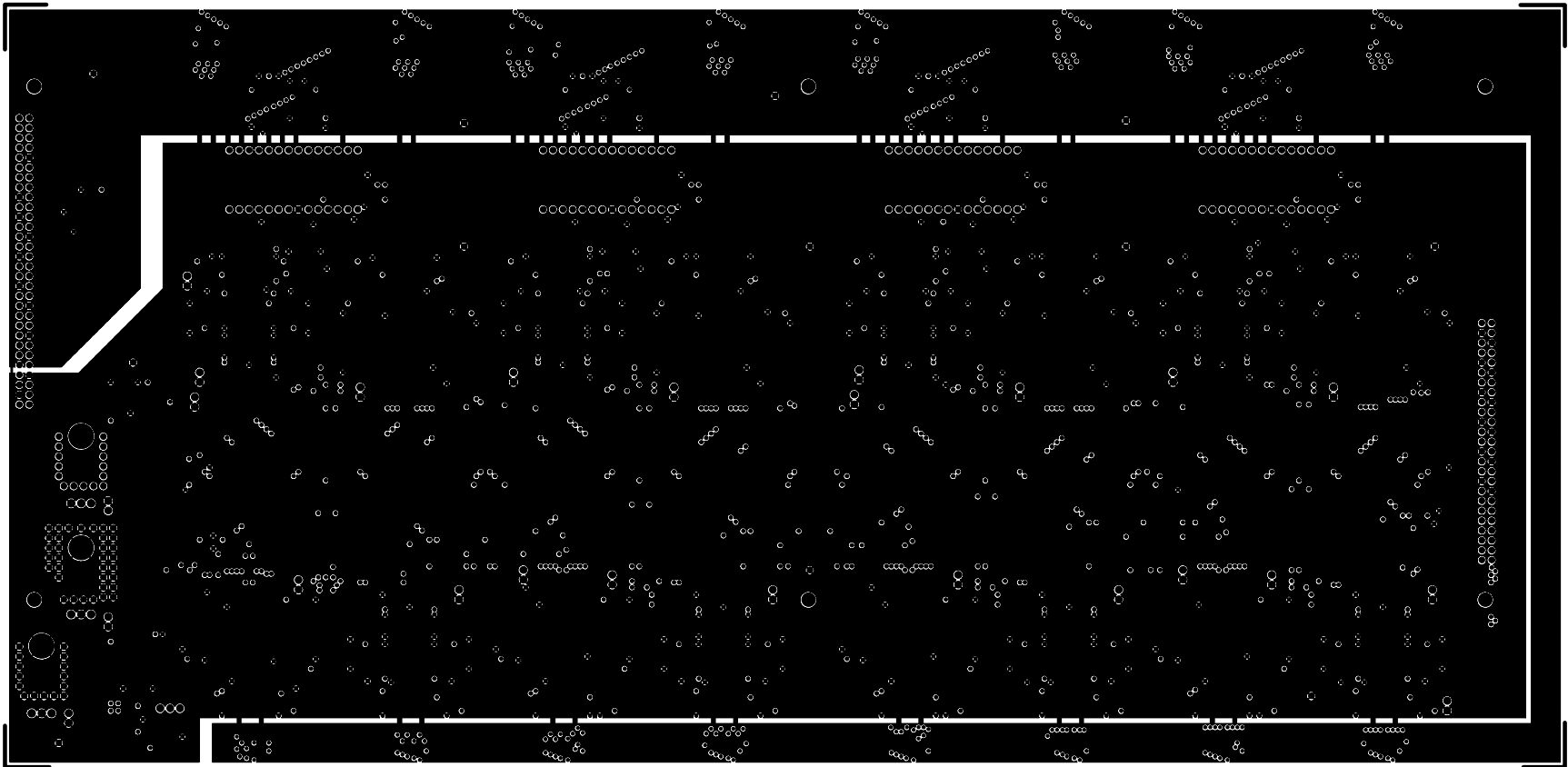



ALESIS 9-40-0210-C "PWRPLANE LAYER 3"

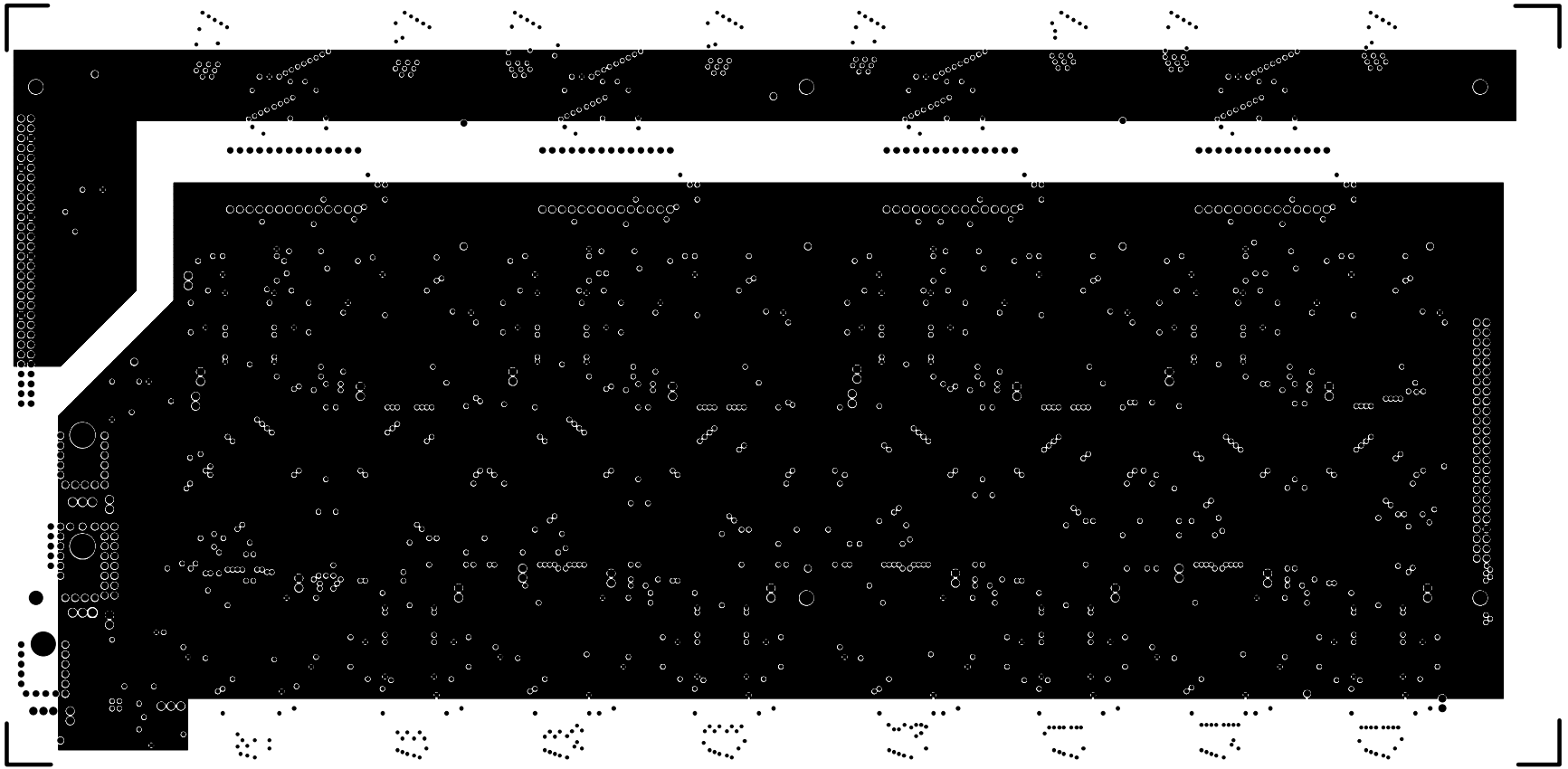



ALESIS 9-40-0210-C "BOTTRACE"

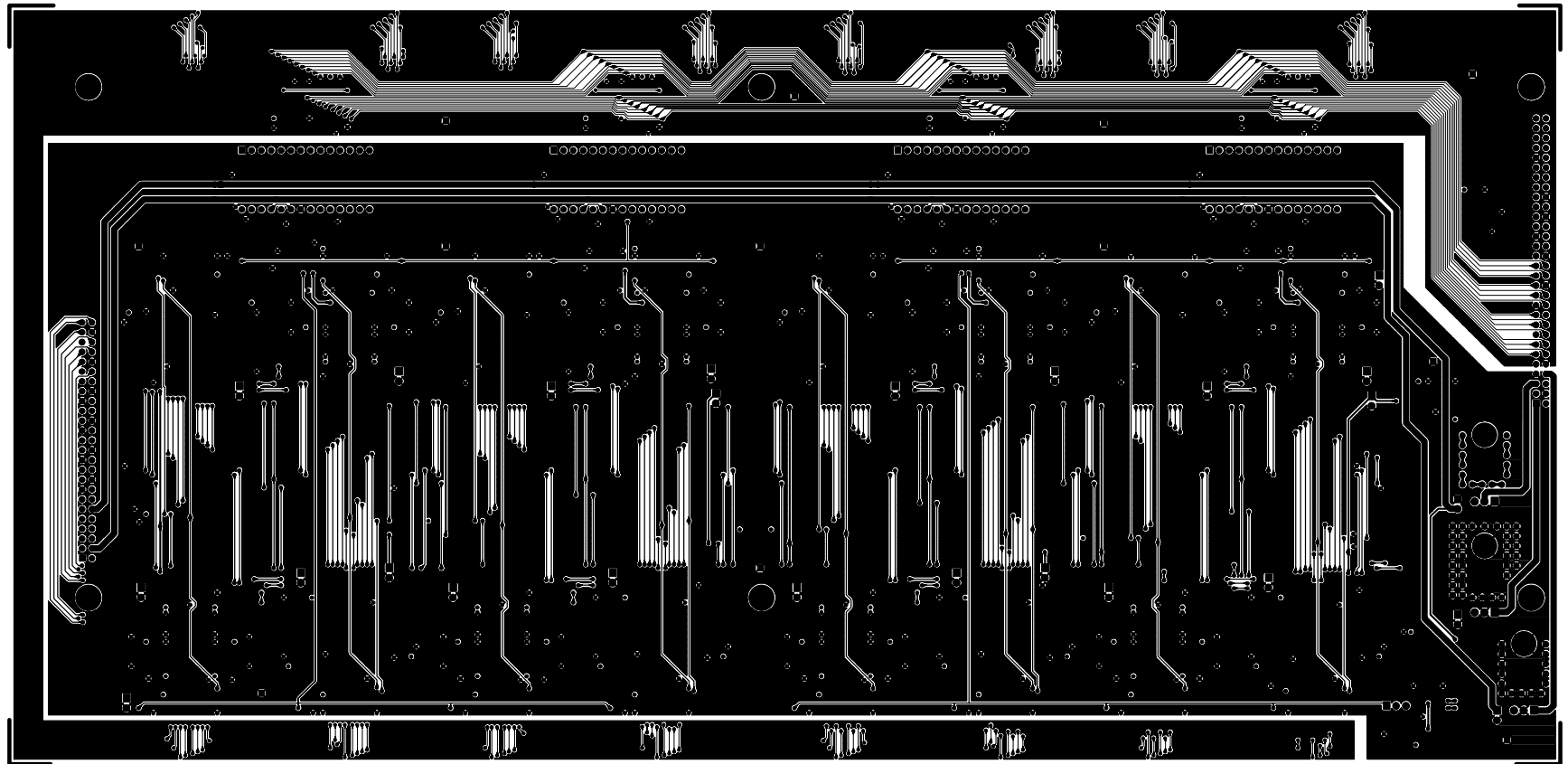

6

5

4

3

2

1

REVISION RECORD			
LTR	ECO NO:	APPROVED:	DATE:

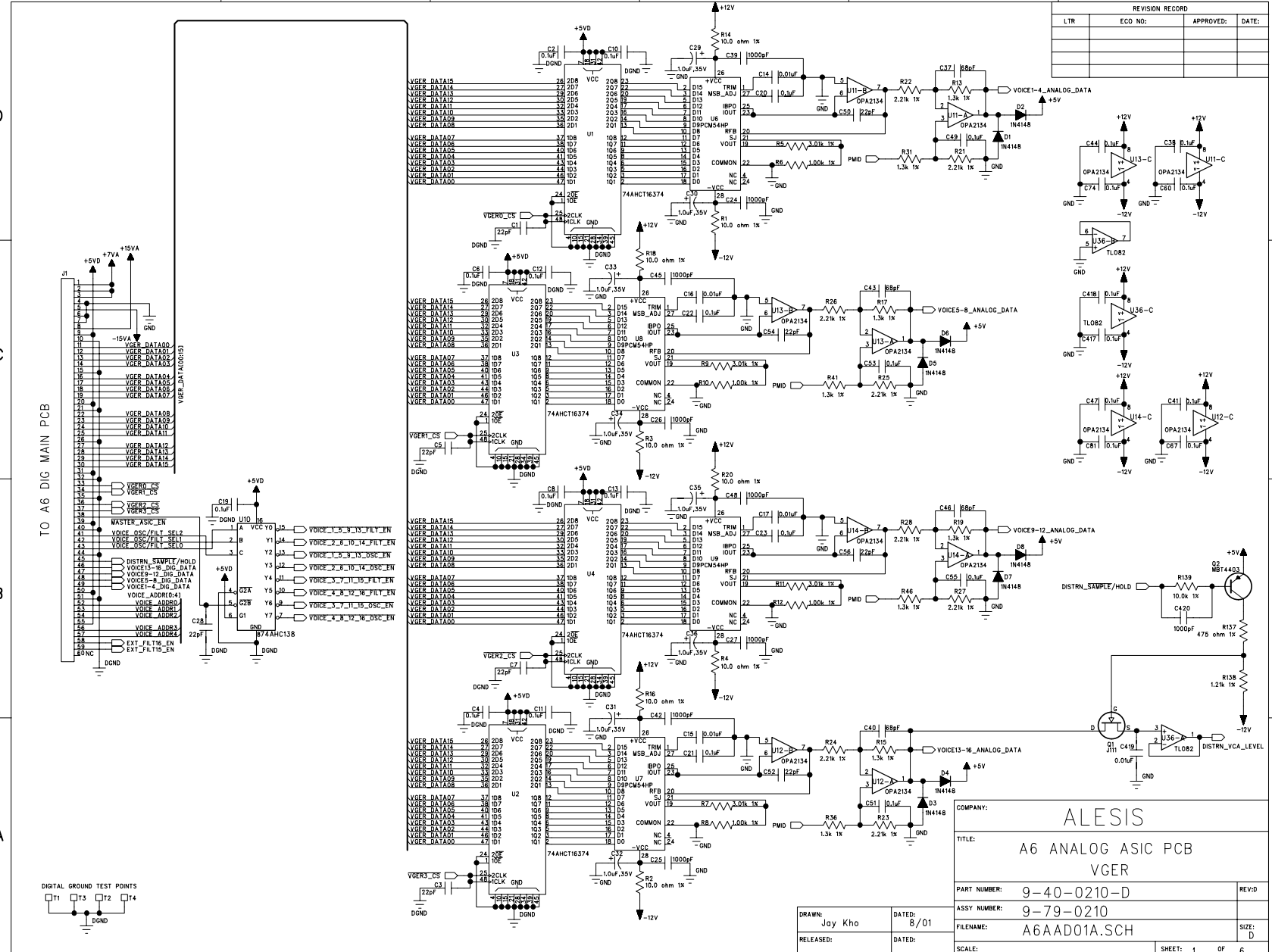

TO A6 DIG MAIN PCB

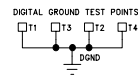

COMPANY: **ALESIS**

TITLE: **A6 ANALOG ASIC PCB**
VGER

PART NUMBER: **9-40-0210-D** REV:D

ASSY NUMBER: **9-79-0210**

FILENAME: **A6AAD01A.SCH** SIZE: D

SCALE: SHEET: 1 OF 6

DRAWN: **Jay Kho** DATED: **8/01**

RELEASED: DATED:

6

5

4

3

2

1

D

D

C

C

B

B

A

A

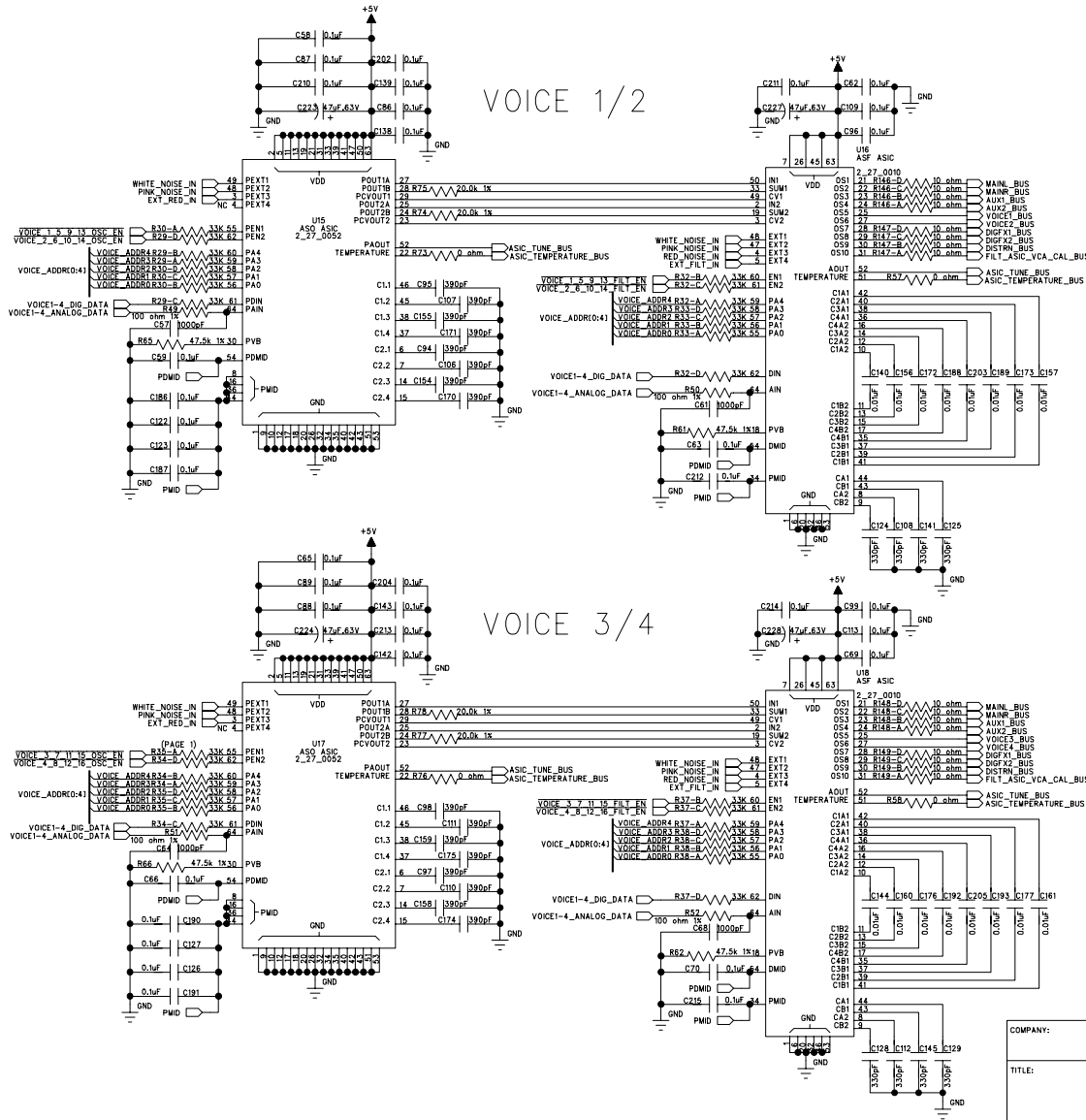

REVISION RECORD			
LTR	ECD NO:	APPROVED:	DATE:

COMPANY:		ALEXIS	
TITLE: A6 ANALOG ASIC PCB VOICES 1-4			
PART NUMBER:	9-40-0210-D	REV:D	
ASSY NUMBER:	9-79-0210		
FILENAME:	A6AAD01A.SCH		
SCALE:			

DRAWN:	Jay Kho	DATED:	8/01
RELEASED:		DATED:	

6

5

4

3

2

1

D

D

C

C

B

B

A

A

VOICE 5/6

VOICE 7/8

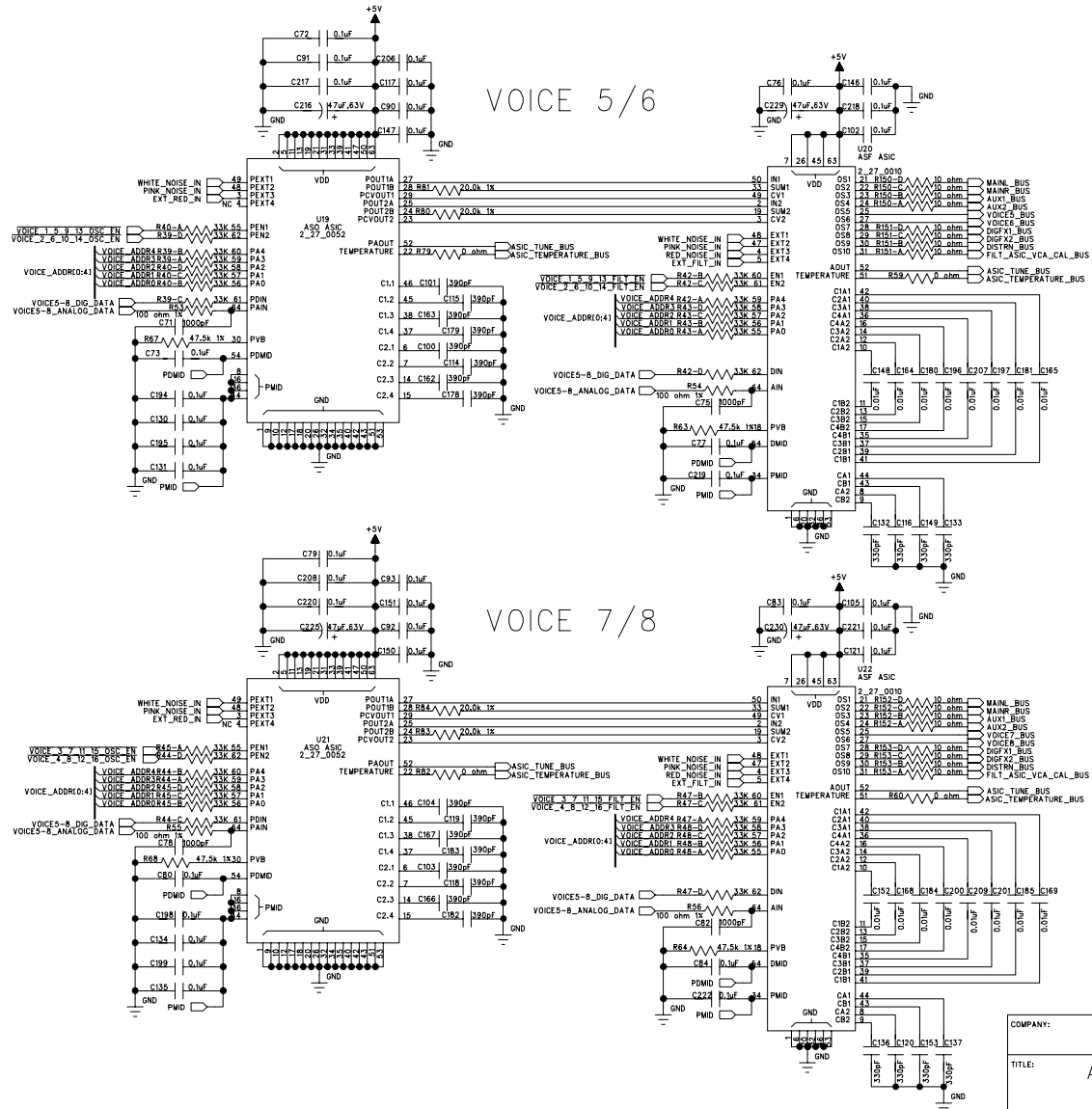

REVISION RECORD			
LTR	ECD NO:	APPROVED:	DATE:

COMPANY:		ALEXIS	
TITLE: A6 ANALOG ASIC PCB VOICES 5-8			
PART NUMBER: 9-40-0210-D			REV:D
ASSY NUMBER: 9-79-0210			
FILENAME: A6AAD01A.SCH			SIZE: D
SCALE:			
DRAWN: Jay Kho	DATED: 8/01		
RELEASED:	DATED:		
SHEET: 3			OF 6

6

5

4

3

2

1

REVISION RECORD			
LTR	ECD NO:	APPROVED:	DATE:

VOICE 9/10

VOICE 11/12

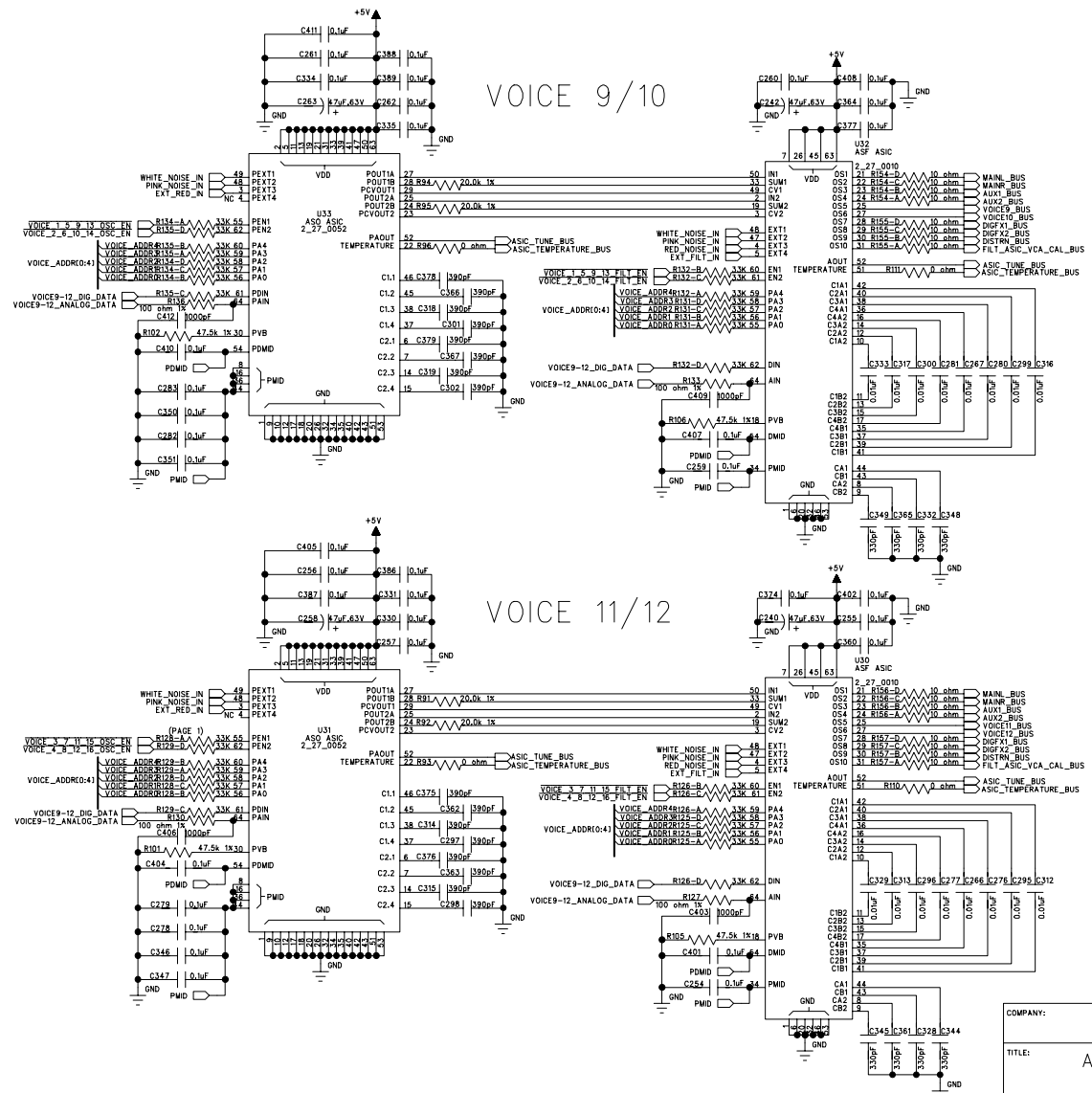

COMPANY: ALESIS

TITLE: A6 ANALOG ASIC PCB
VOICES 9-12

PART NUMBER: 9-40-0210-D REV:D

ASSY NUMBER: 9-79-0210

FILENAME: A6AAD01A.SCH

SCALE: SHEET: 4 OF 6

DRAWN: Jay Kho DATED: 8/01

RELEASED: DATED:

D

D

C

C

B

B

A

A

6

5

4

3

2

1

REVISION RECORD			
LTR	ECD NO:	APPROVED:	DATE:

VOICE 13/14

VOICE 15/16

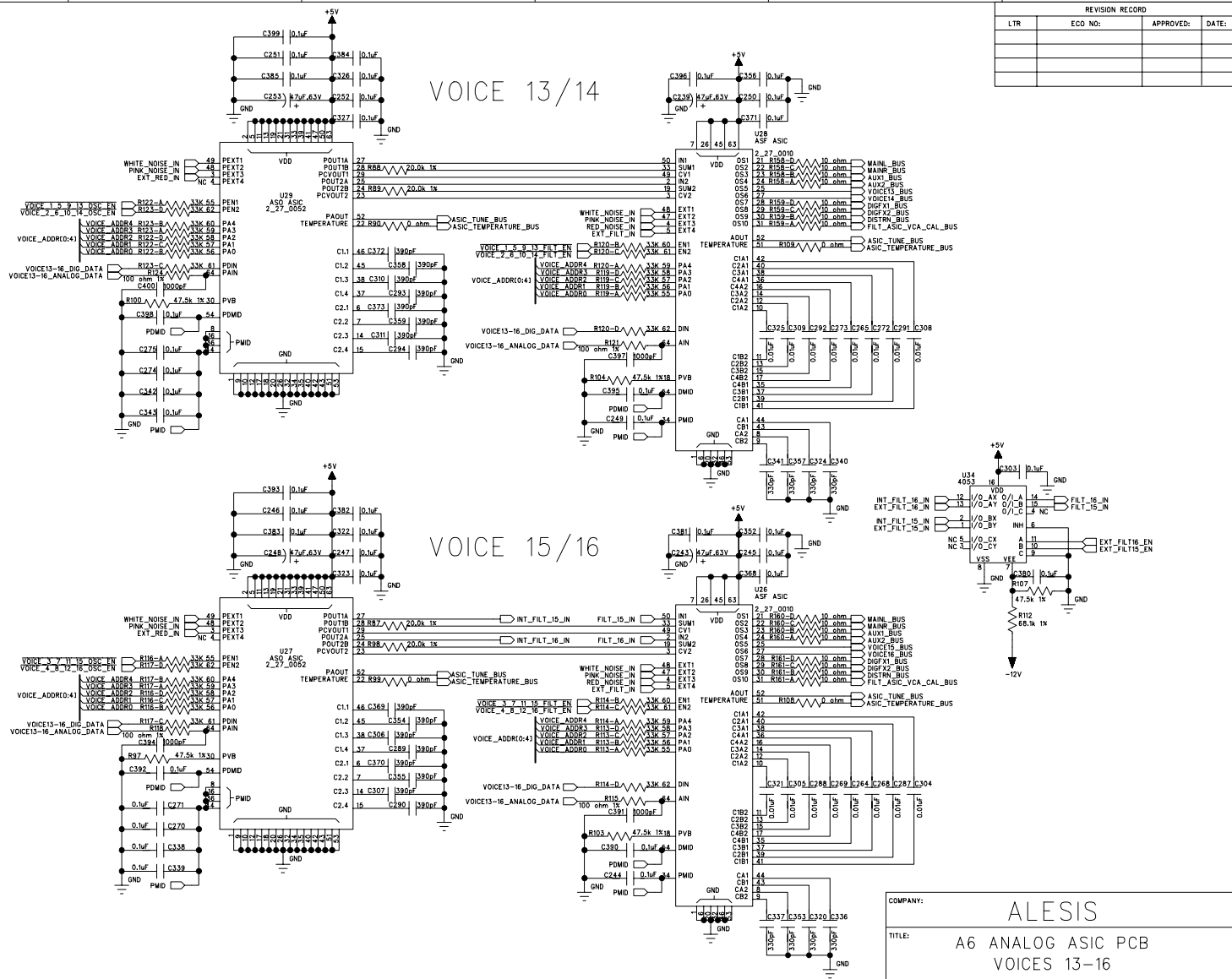

6

5

4

3

2

1

REVISION RECORD			
LTR	ECD NO:	APPROVED:	DATE:

D

D

C

C

B

B

A

A

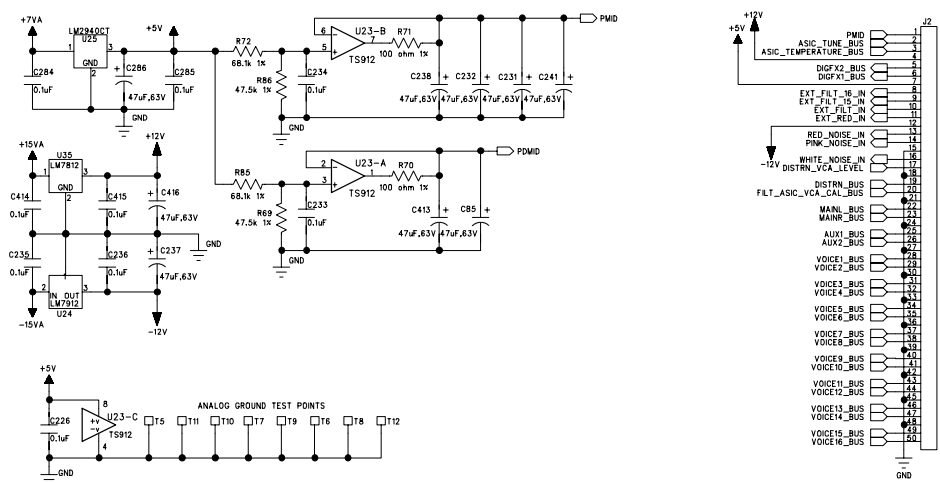

TO A6 ANALOG MASTER PCB

COMPANY:		ALEXIS	
TITLE:		A6 ANALOG ASIC PCB MISCELLANEOUS	
PART NUMBER:	9-40-0210-D	REV-D	
ASSY NUMBER:	9-79-0210		
FILENAME:	A6AAD01A.SCH	SIZE:	D
SCALE:		SHEET:	6 OF 6

DRAWN:	Jay Kho	DATED:	8/01
RELEASED:		DATED:	

ALESIS 9-40-0210-D "TOPASSY"

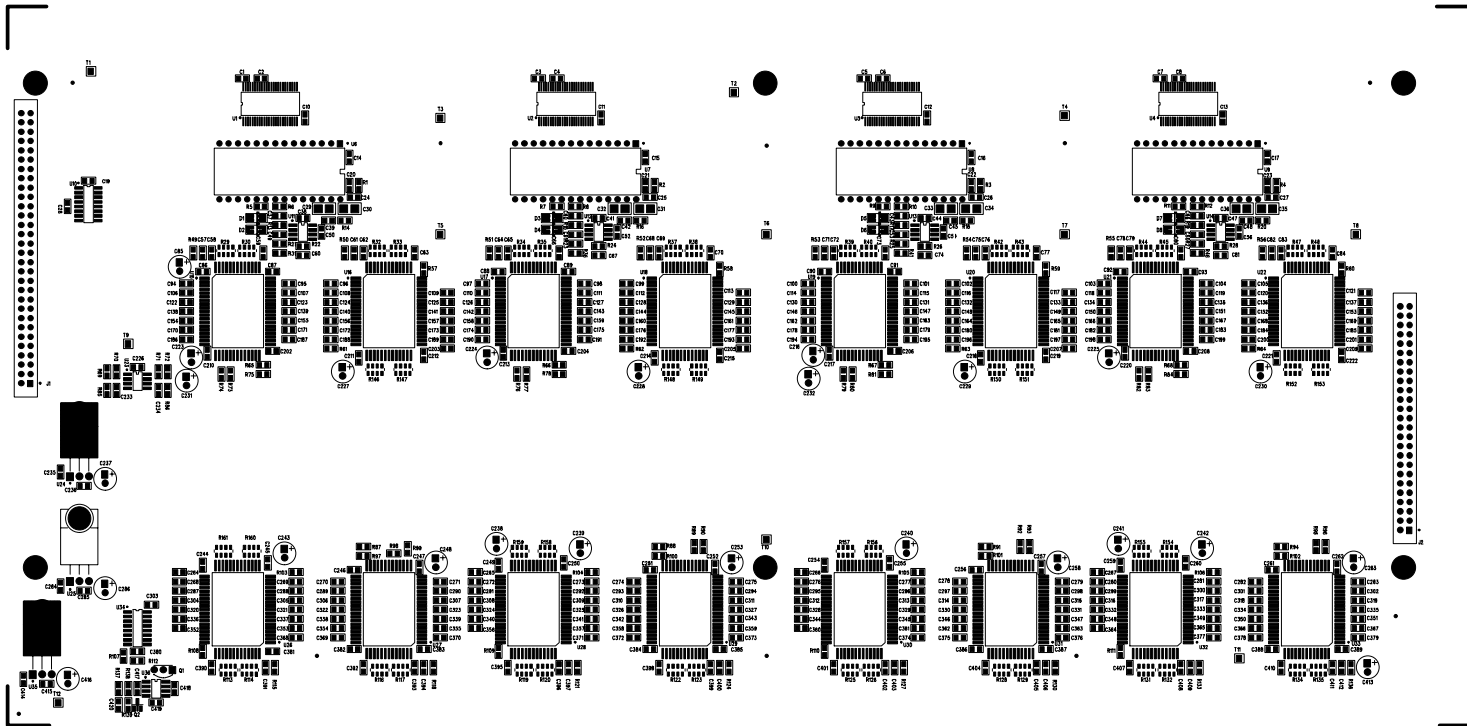

Mounting Instructions for U24, U25, and U35
(to be assembled before soldering).

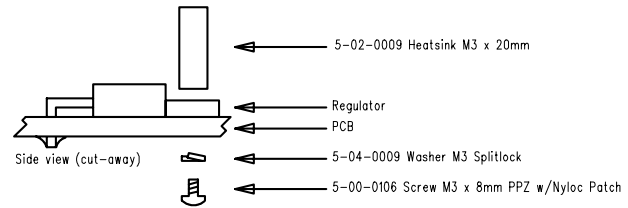



ALESIS 9-40-0210-D "TOPTRACE"

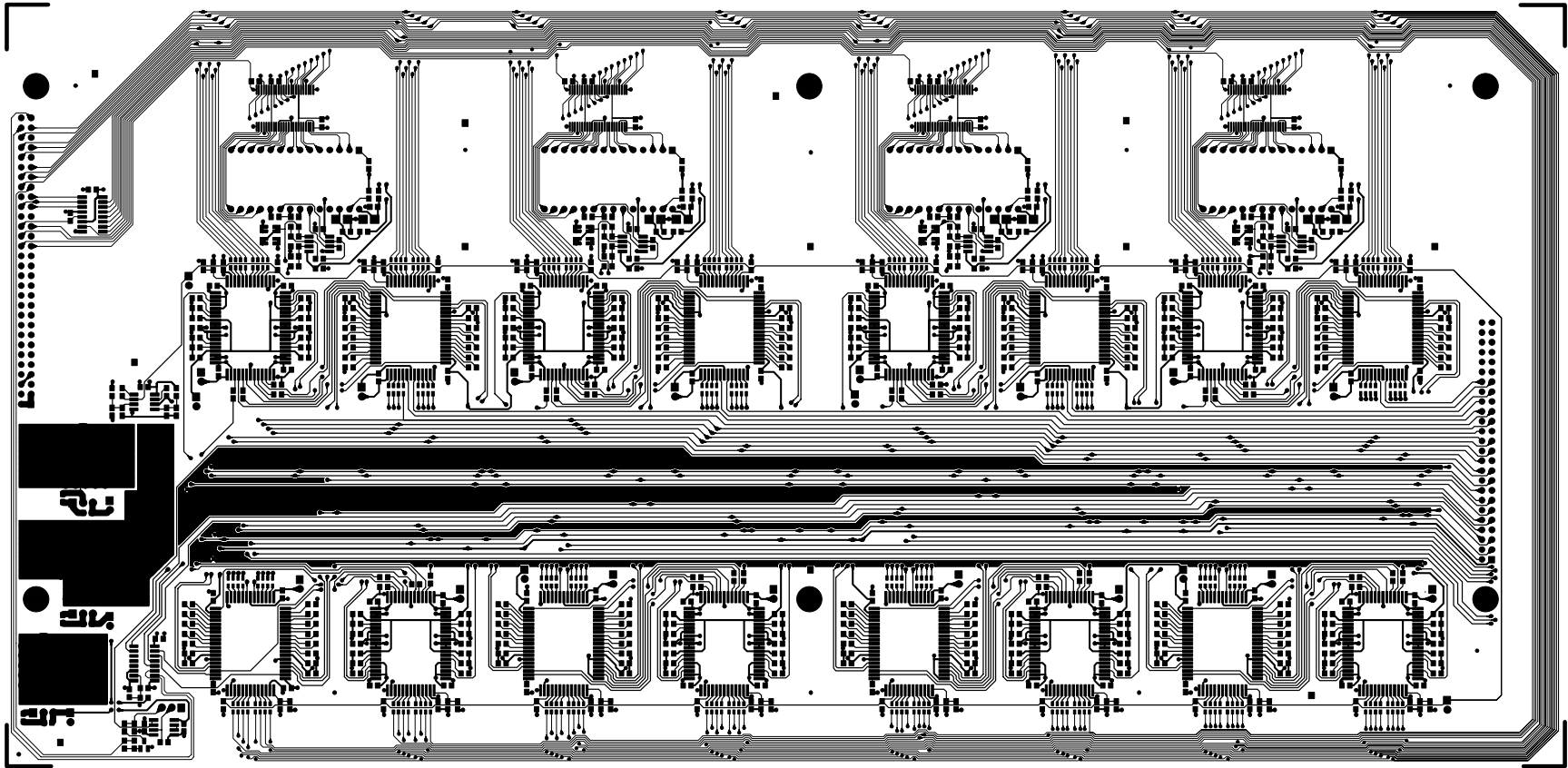



ALESIS 9-40-0210-D "GNDPLANE LAYER 2"

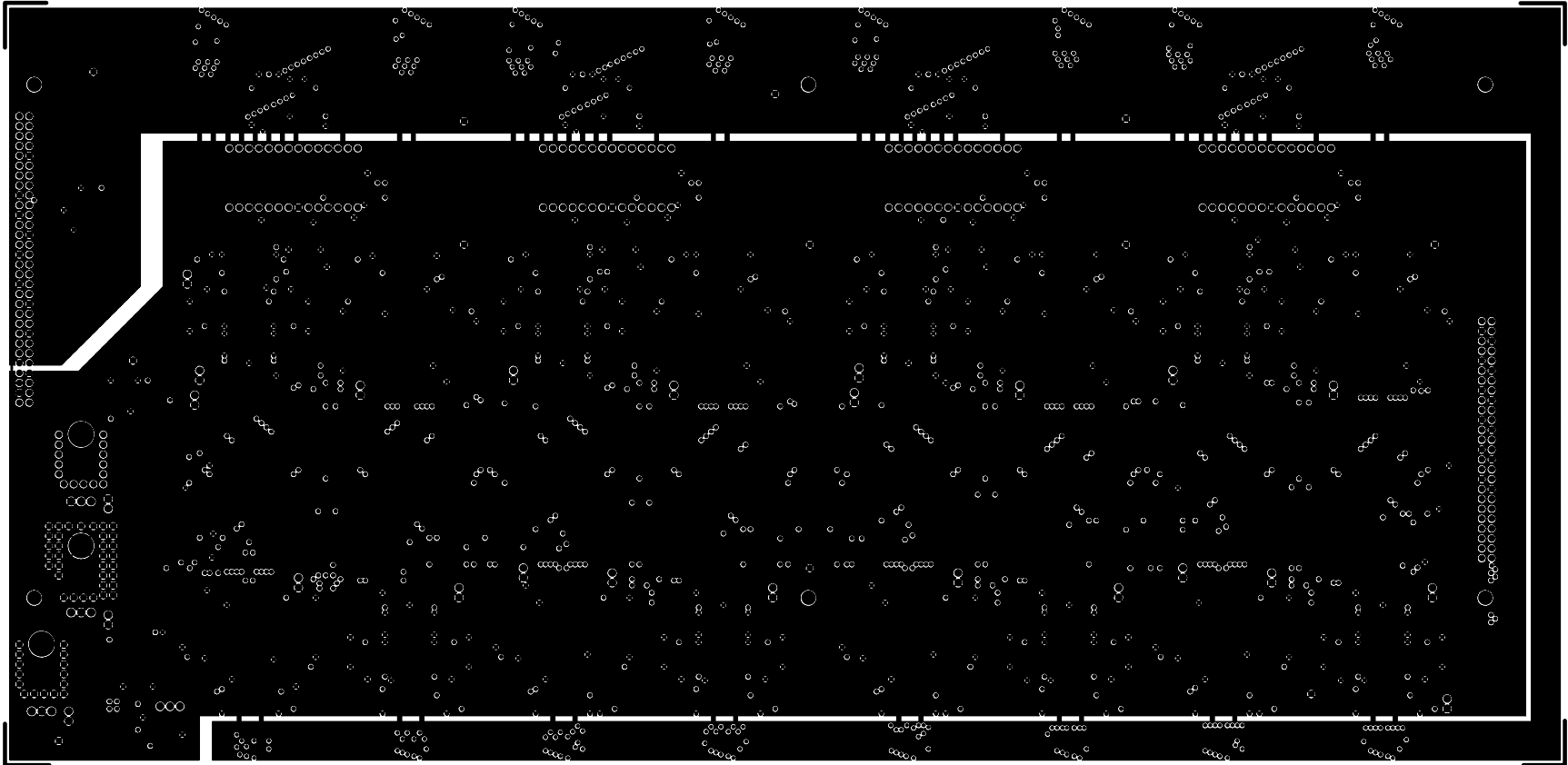



ALESIS 9-40-0210-D "PWRPLANE LAYER 3"

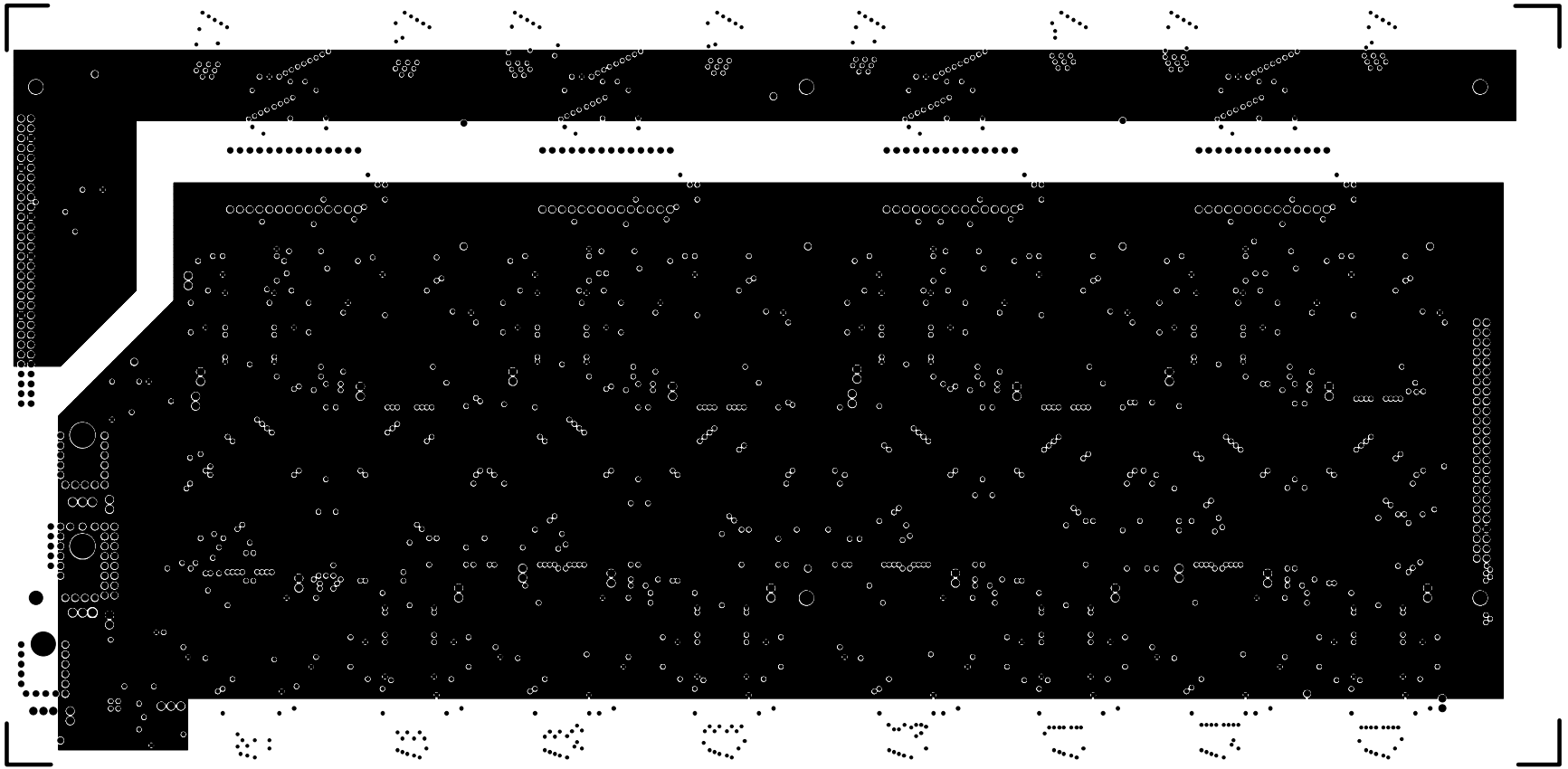



"AFES2 9-40-0310-D" BOTTRAVE

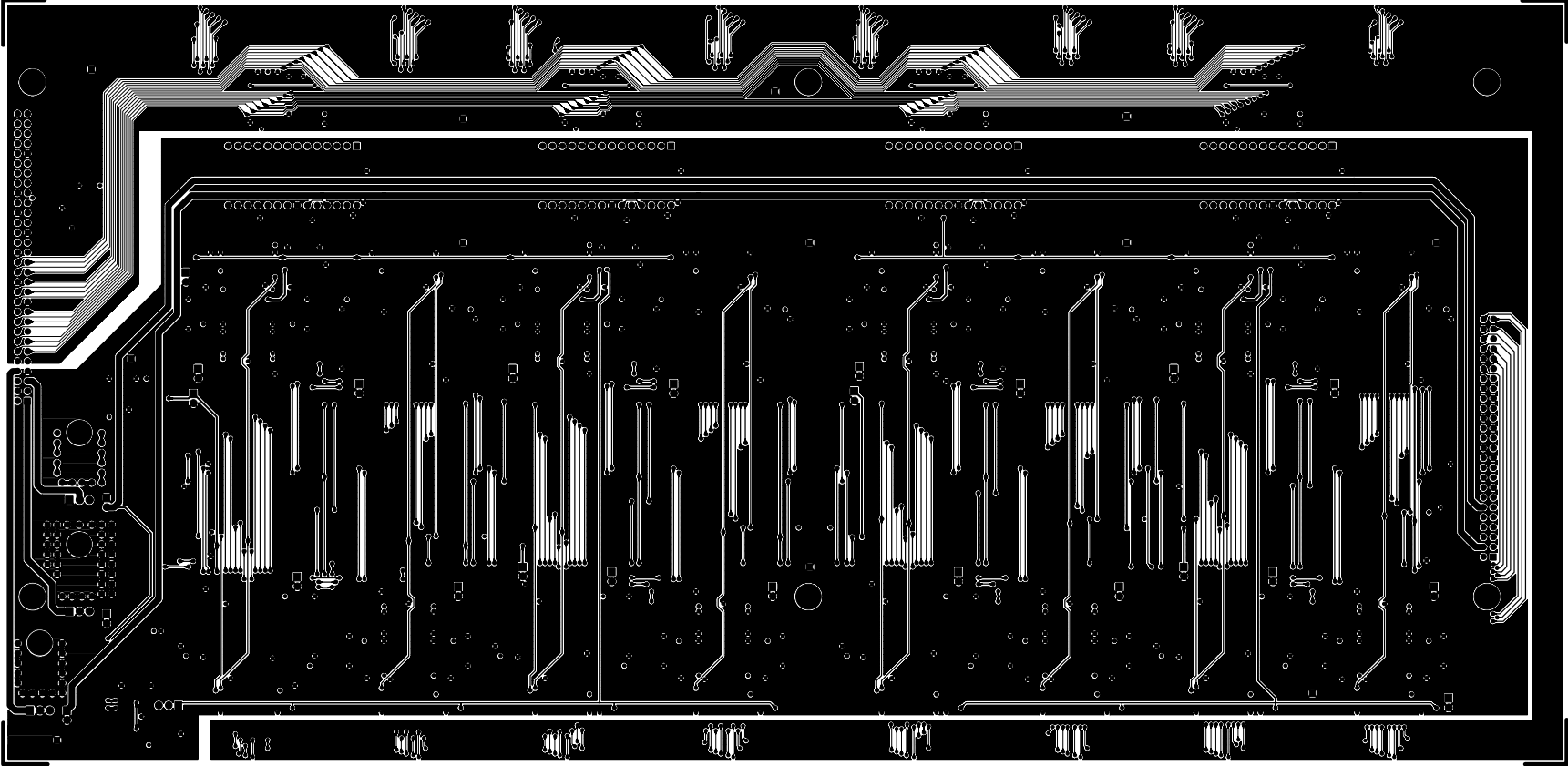

6

5

4

3

2

1

DISTORTION CIRCUIT

DISTORTION VCA

REVISION RECORD			
LTR	ECO NO:	APPROVED:	DATE:

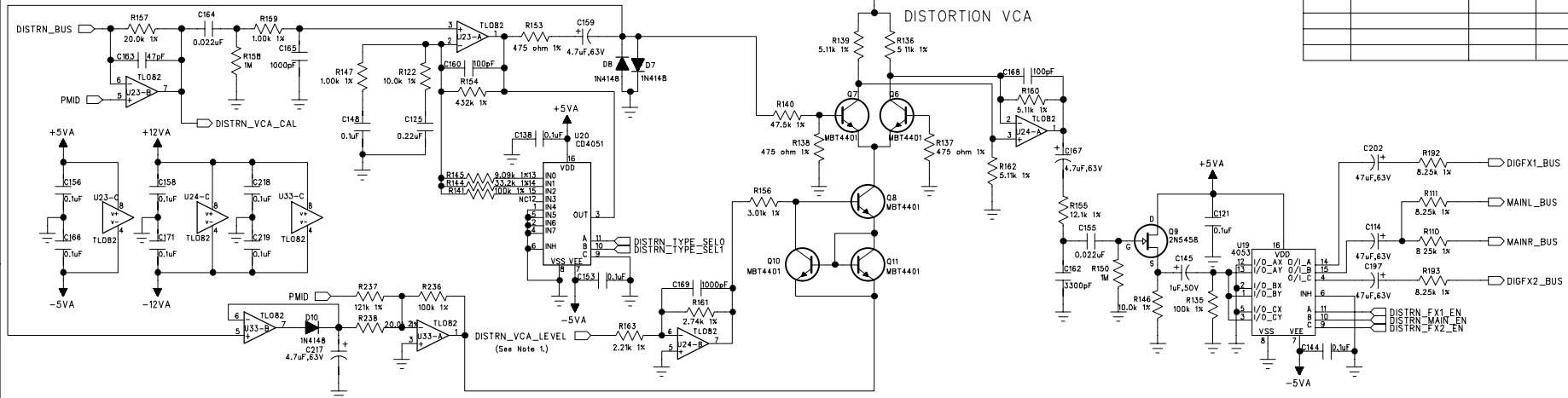

FX SENDS

FX RETURNS

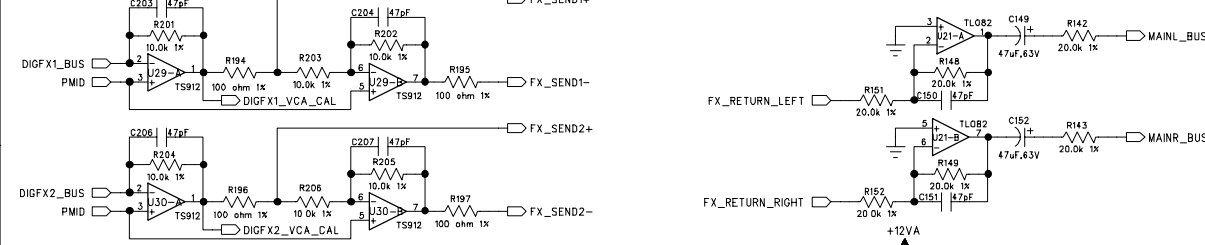

V1	VCA_CAL	R211	47.0k 1x
V2	VCA_CAL	R212	47.0k 1x
V3	VCA_CAL	R213	47.0k 1x
V4	VCA_CAL	R214	47.0k 1x
V5	VCA_CAL	R215	47.0k 1x
V6	VCA_CAL	R216	47.0k 1x
V7	VCA_CAL	R217	47.0k 1x
V8	VCA_CAL	R218	47.0k 1x
V9	VCA_CAL	R219	47.0k 1x
V10	VCA_CAL	R220	47.0k 1x
V11	VCA_CAL	R221	47.0k 1x
V12	VCA_CAL	R222	47.0k 1x
V13	VCA_CAL	R223	47.0k 1x
V14	VCA_CAL	R224	47.0k 1x
V15	VCA_CAL	R225	47.0k 1x
V16	VCA_CAL	R226	47.0k 1x
V17	VCA_CAL	R227	47.0k 1x
V18	VCA_CAL	R228	47.0k 1x
V19	VCA_CAL	R229	47.0k 1x
V20	VCA_CAL	R230	47.0k 1x
MAIN1	VCA_CAL	R231	20.0k 1x
MAINR	VCA_CAL	R232	20.0k 1x
DIGFX1	VCA_CAL	R233	10.0k 1x
DIGFX2	VCA_CAL	R234	10.0k 1x
DISTRN	VCA_CAL	R235	20.0k 1x
DISTRN_VCA_CAL	VCA_CAL	R236	20.0k 1x

NOISE GENERATOR

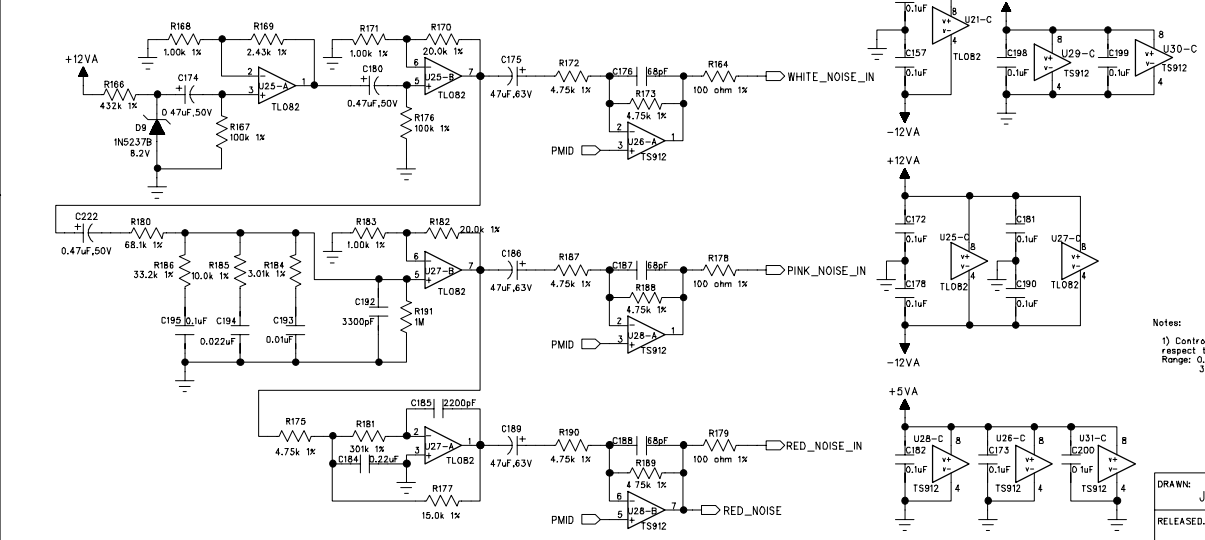

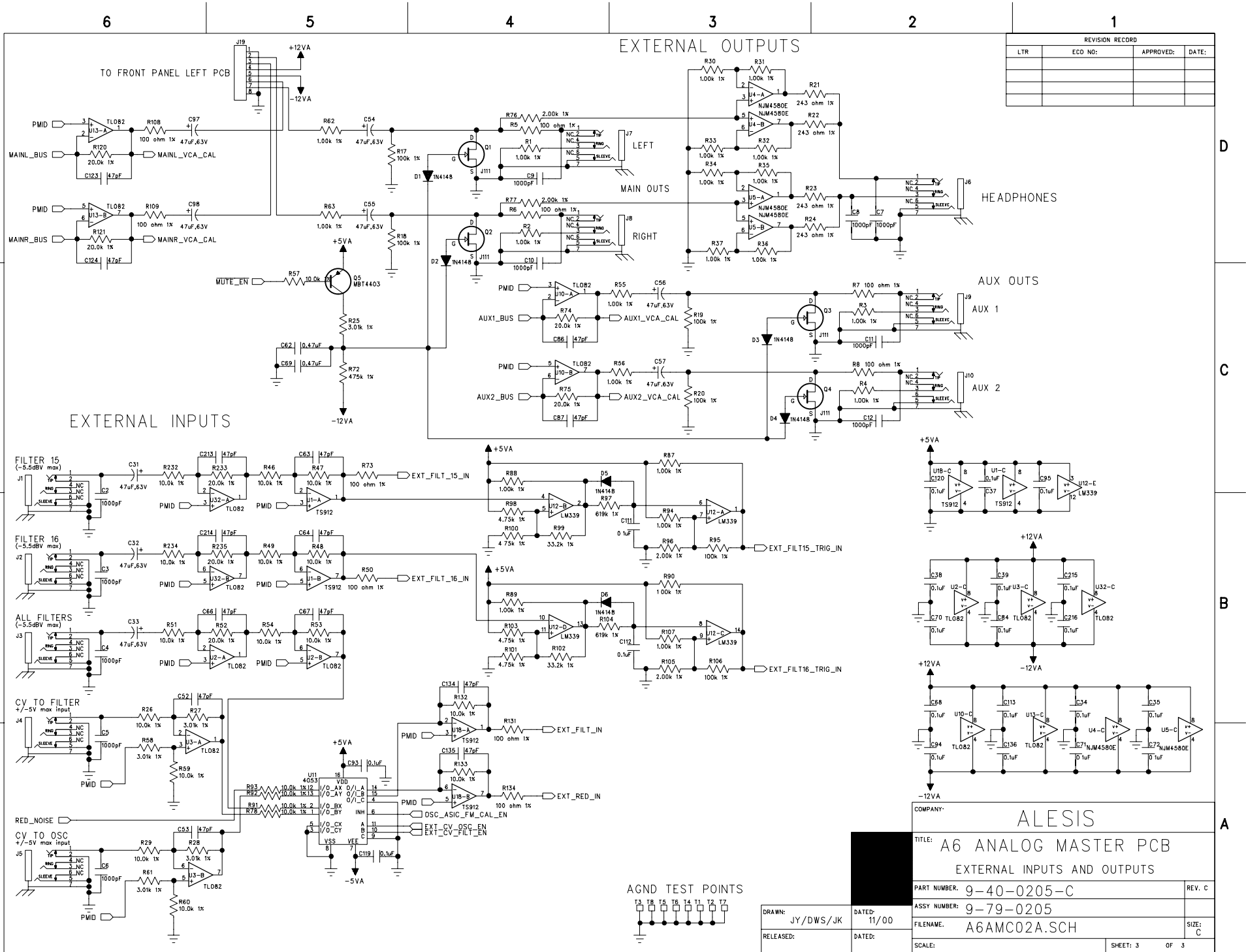

REVISION RECORD			
LTR	ECO NO:	APPROVED:	DATE:

COMPANY:		ALESIS	
TITLE: A6 ANALOG MASTER PCB EXTERNAL INPUTS AND OUTPUTS			
PART NUMBER:		9-40-0205-C	REV. C
ASSY NUMBER:		9-79-0205	
FILENAME:		A6AMC02A.SCH	SIZE: C
SCALE:			SHEET: 3 OF 3

DRAWN:	JY/DWS/JK	DATED:	11/00
RELEASED:		DATED:	

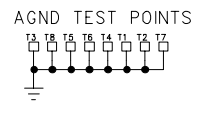

D

D

C

C

B

B

A

A



ALESIS 9-40-0205-C "TOPASSY"

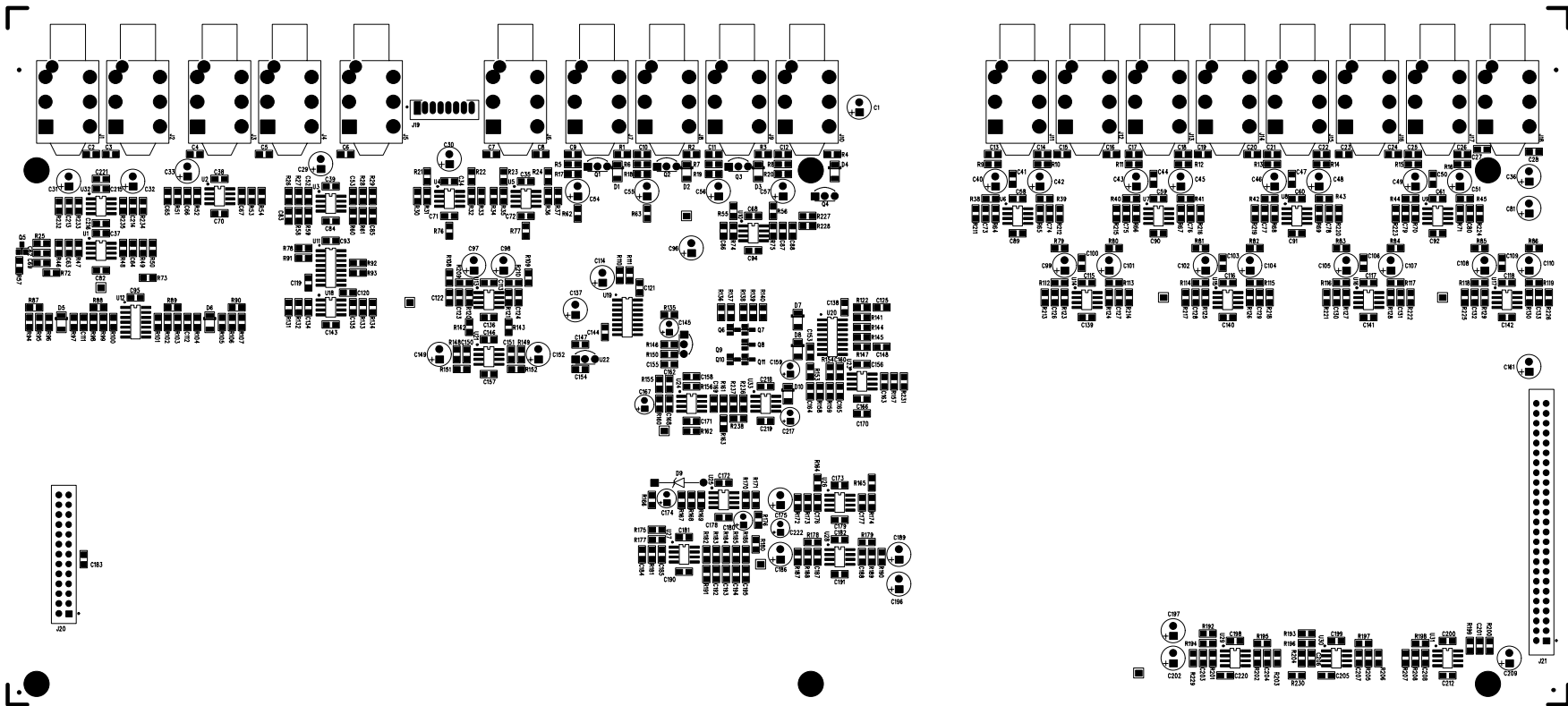



ALESIS 9-40-0205-C "TOPTRACE"

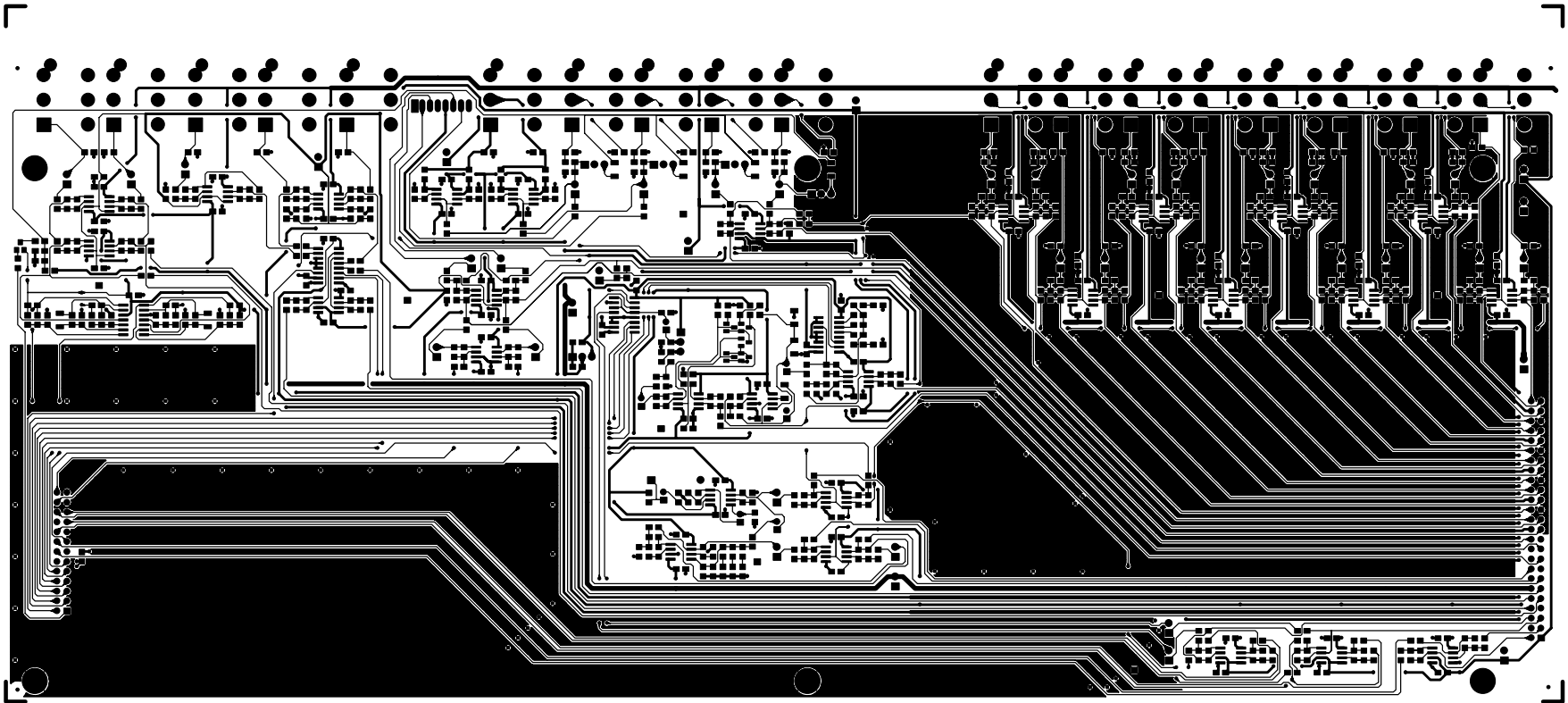

ALESIS 9-40-0205-C "BOTTRACE"

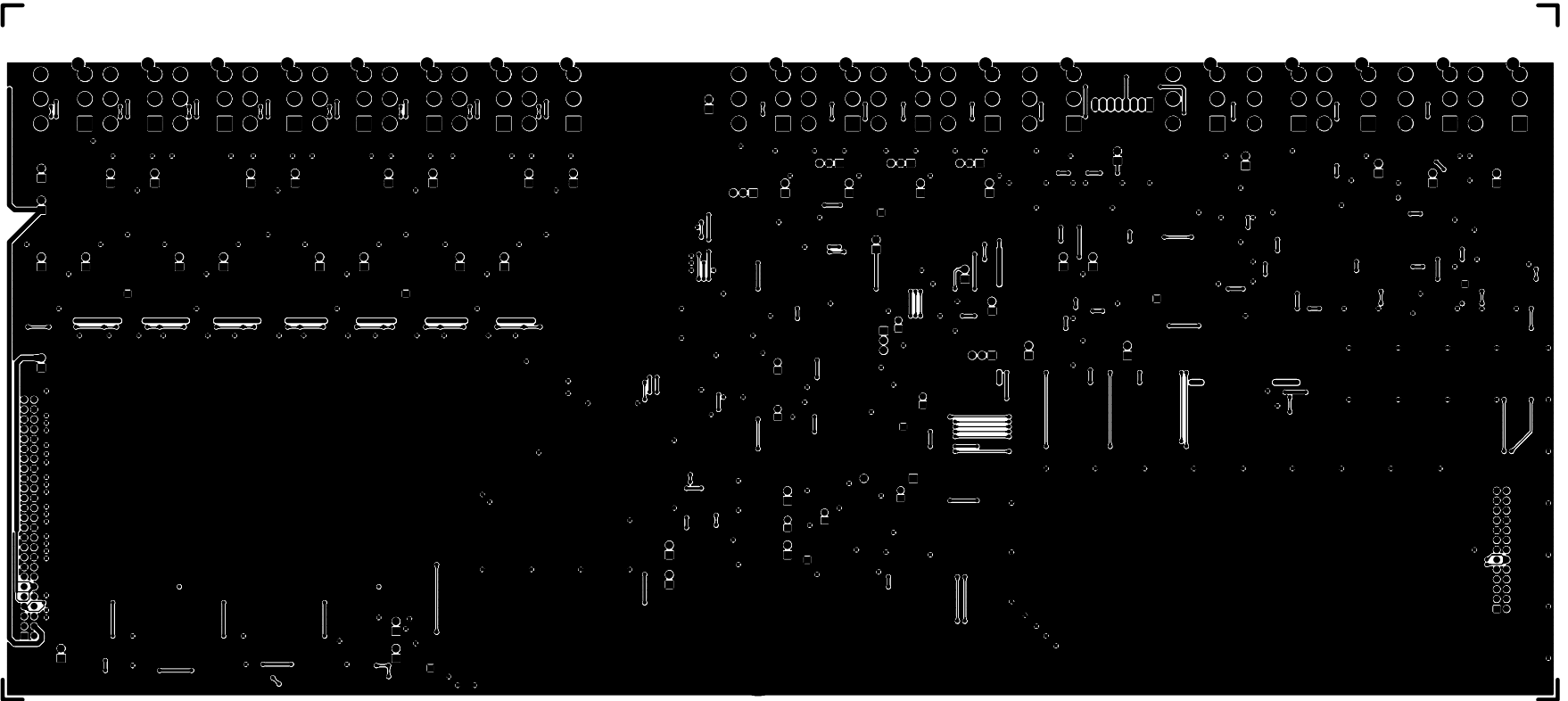

REVISION RECORD			
LTR	ECD NO:	APPROVED:	DATE:

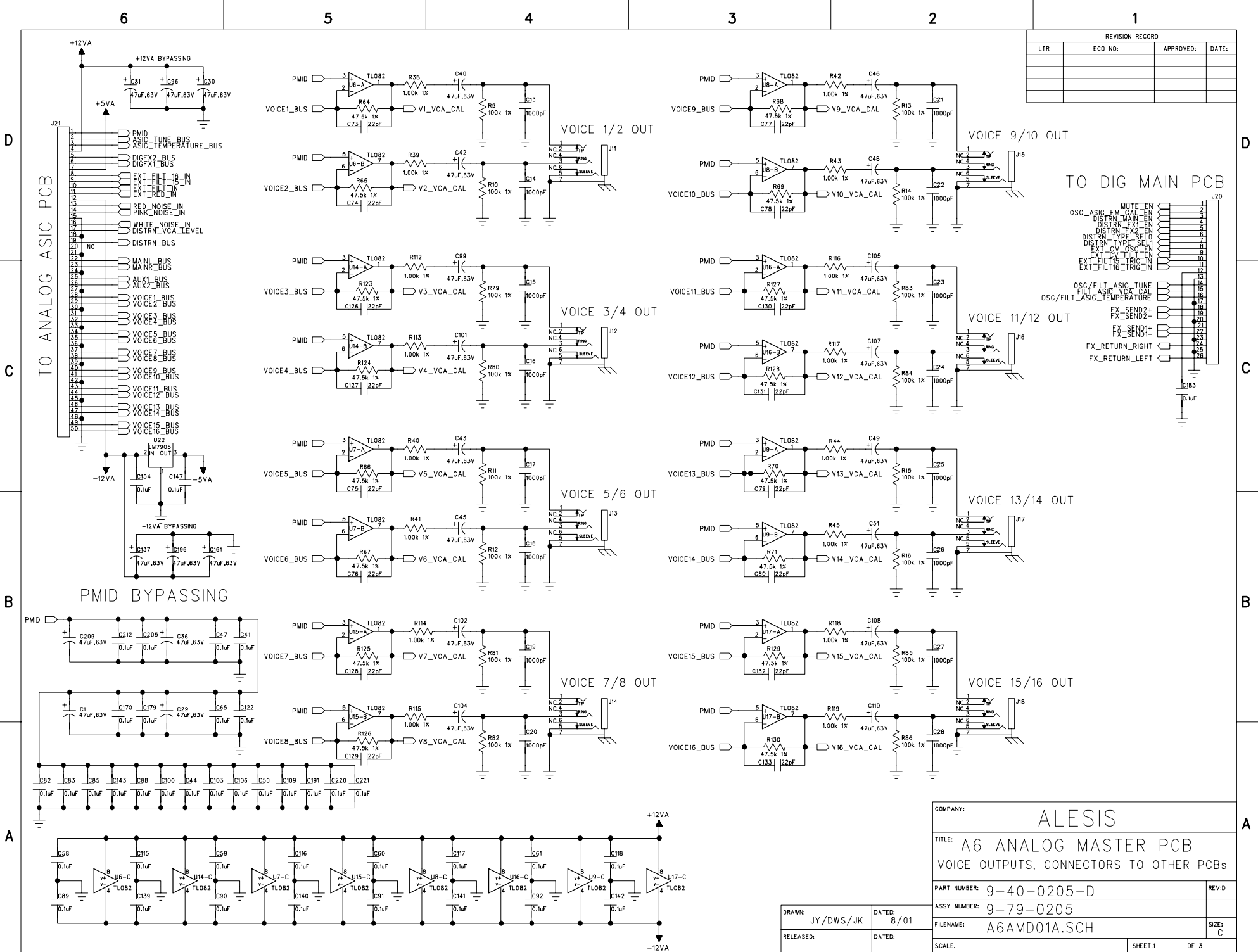

TO DIG MAIN PCB

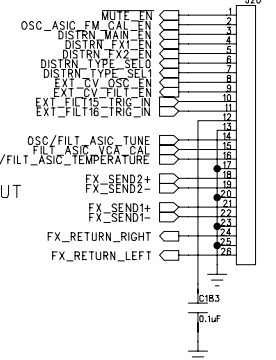

COMPANY:	ALESIS		
TITLE:	A6 ANALOG MASTER PCB VOICE OUTPUTS, CONNECTORS TO OTHER PCBs		
PART NUMBER:	9-40-0205-D	REV:	D
ASSY NUMBER:	9-79-0205		
FILENAME:	A6AMD01A.SCH	SIZE:	C
SCALE:		SHEET:1	OF 3

DRAWN:	JY/DWS/JK	DATED:	8/01
RELEASED:		DATED:	

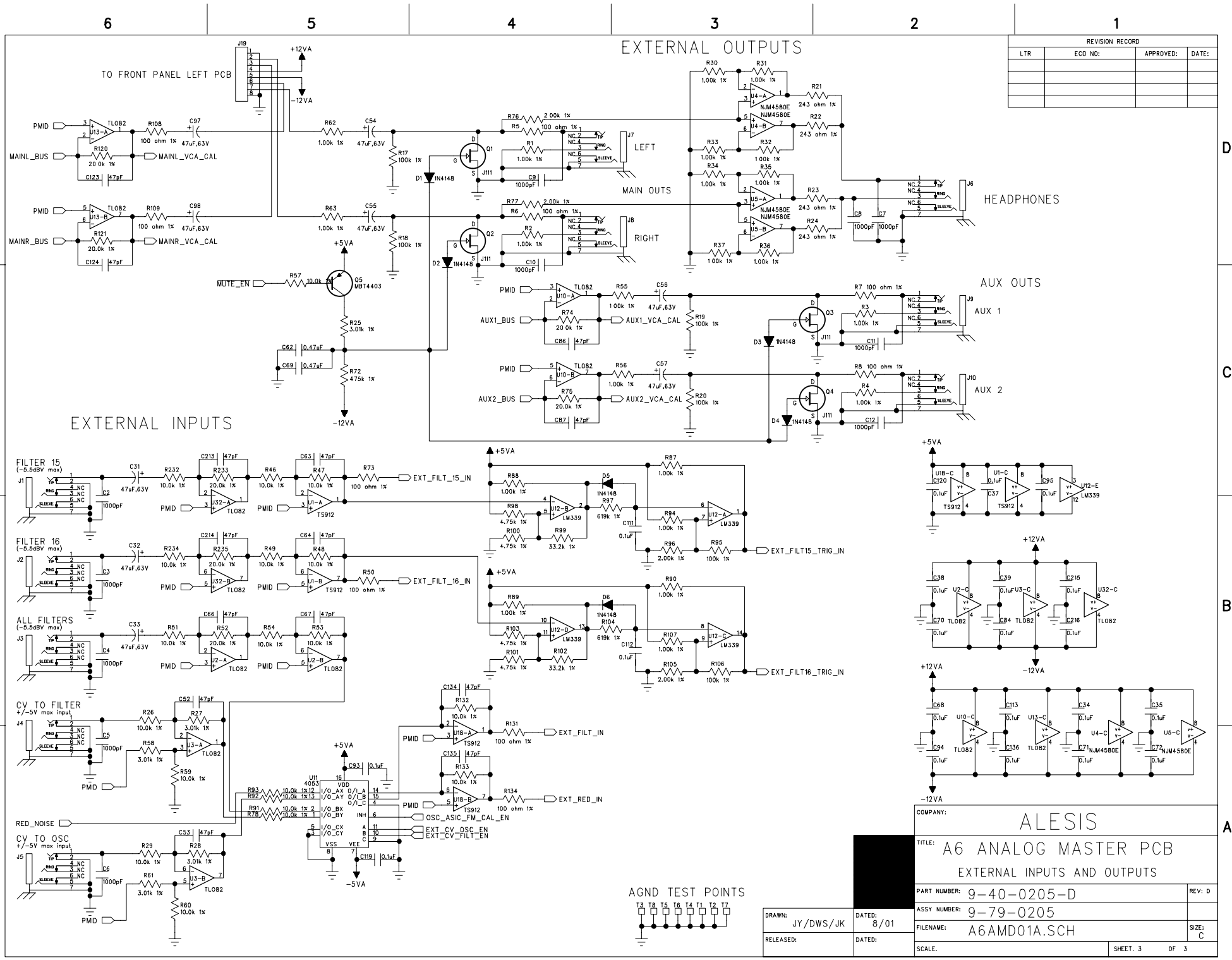

REVISION RECORD			
LTR	ECD NO:	APPROVED:	DATE:

COMPANY:		ALESIS	
TITLE: A6 ANALOG MASTER PCB			
EXTERNAL INPUTS AND OUTPUTS			
PART NUMBER: 9-40-0205-D		REV: D	
ASSY NUMBER: 9-79-0205			
FILENAME: A6AMD01A.SCH		SIZE: C	
SCALE:		SHEET 3 OF 3	

DRAWN: JY/DWS/JK	DATED: 8/01
RELEASED:	DATED:

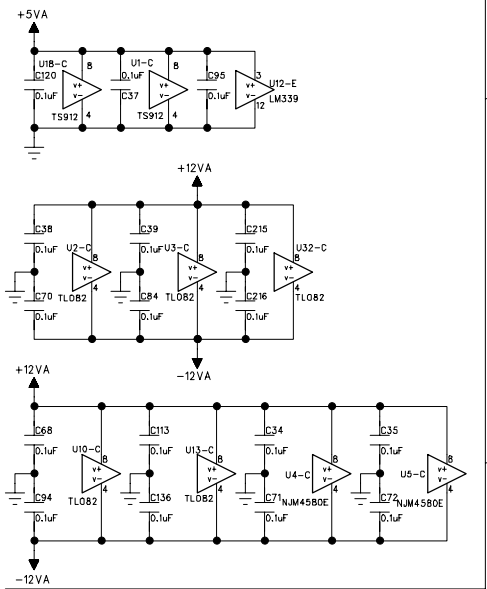
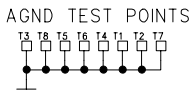



ALESIS 9-40-0205-D "TOPASSY"

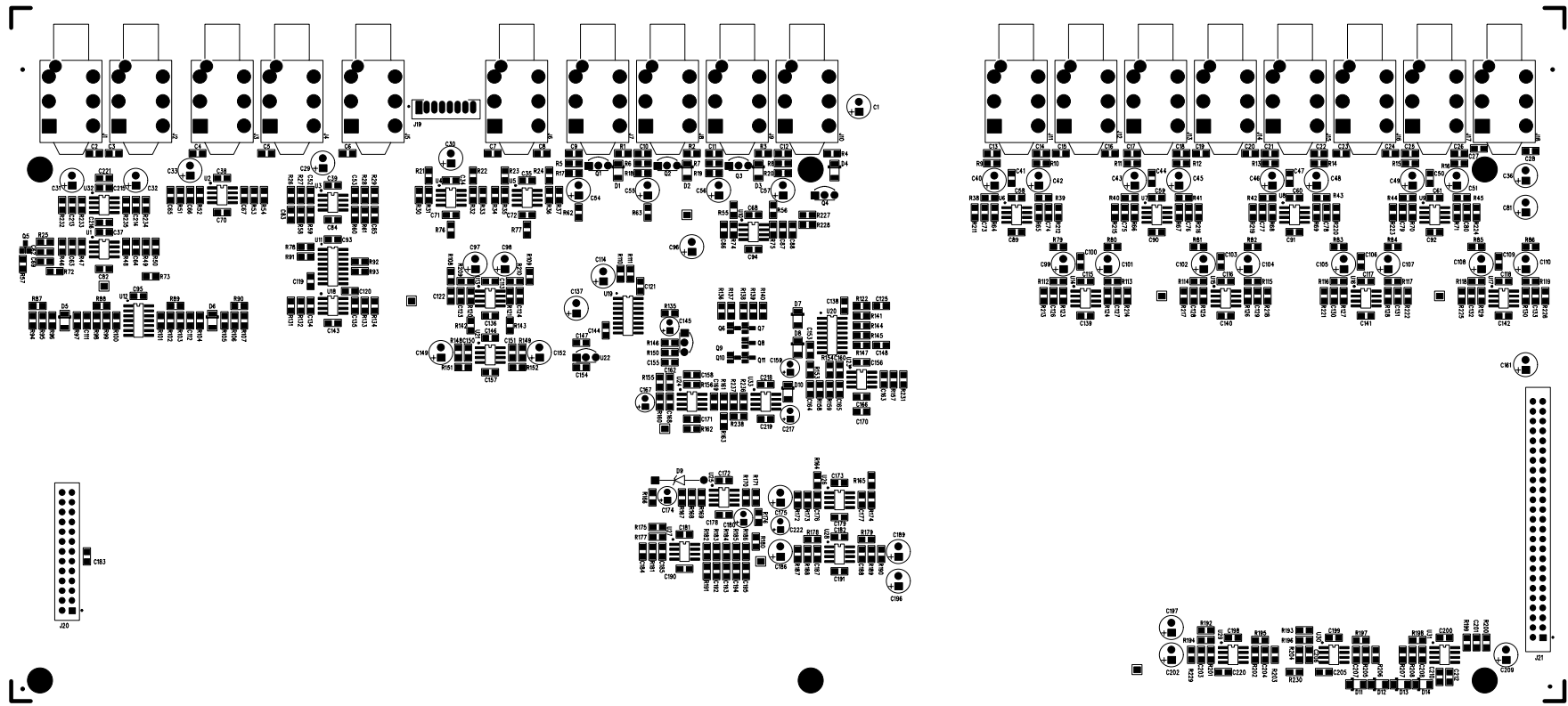



ALESIS 9-40-0205-D "TOPTRACE"

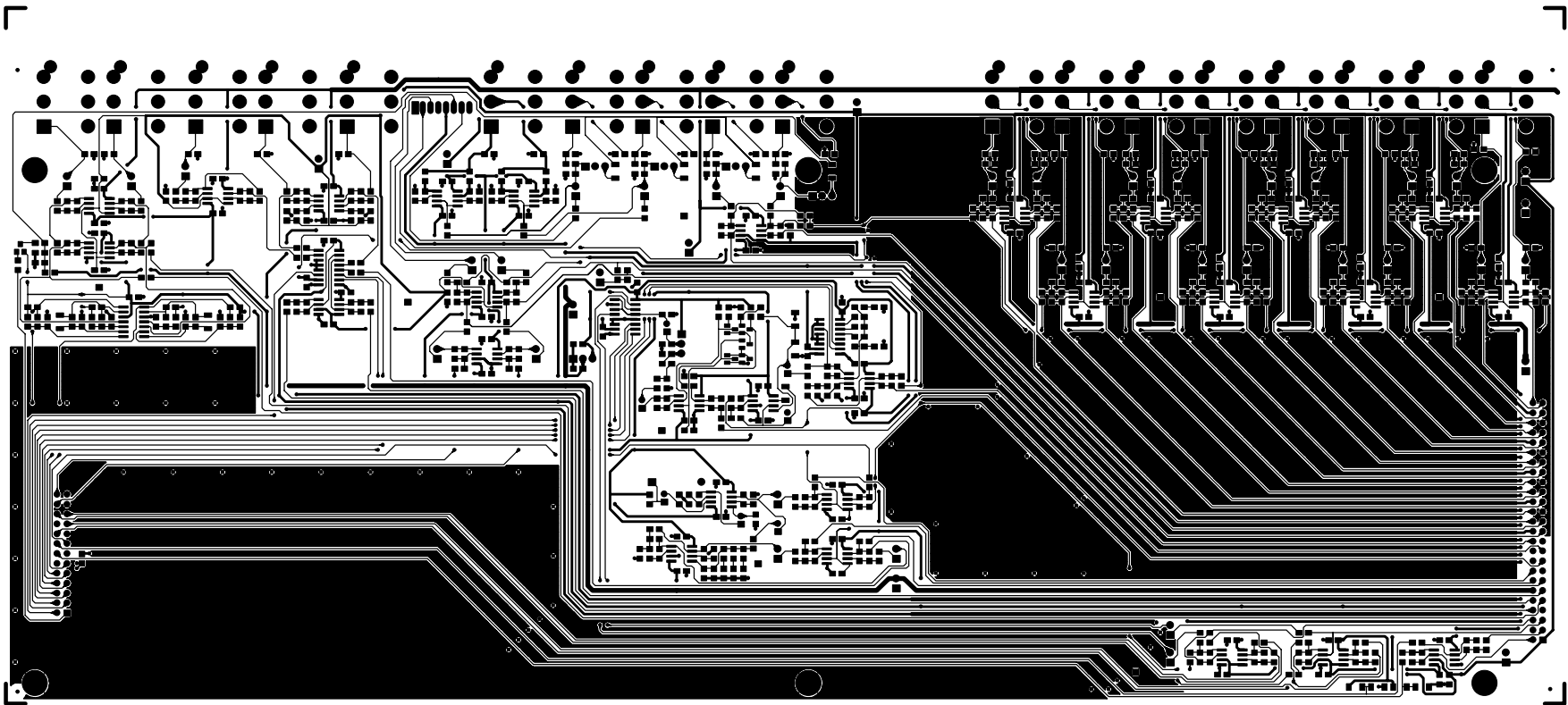



VLE212 3-40-0303-D "BOLTRACE"

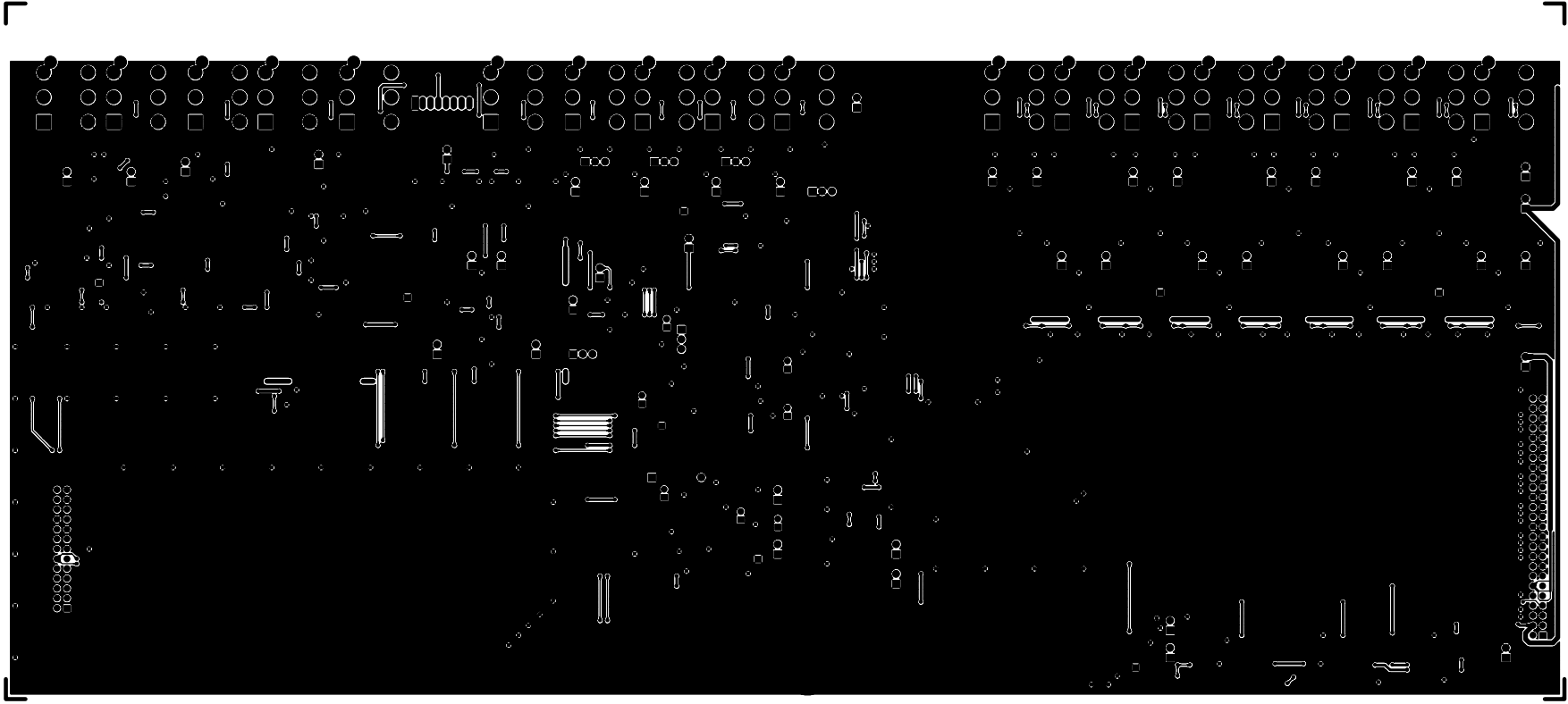

ALESIS ASSEMBLY DRAWING "TOP" 9-79-0207-C

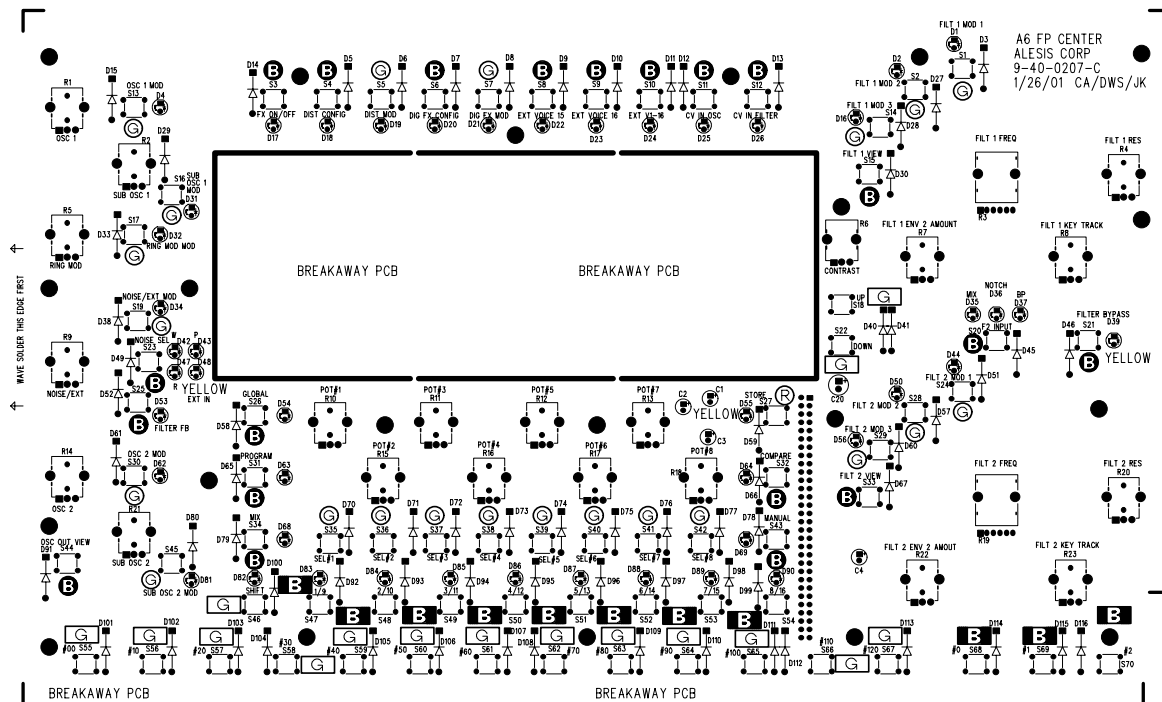

1. Wave solder all surface mount parts and thru hole leads.
2. Board designed to be wave soldered, straight edge first (refer to note with arrows on this drawing)
3. Hand stuff all thru hole components on topside and make sure they are flush (flat) against the PCB.
4. Before wavesoldering, mask J1 pads (will be assembled bottomsides)
5. Refer to drawings (see below) for assembling and inserting LEDs and spacers. Insert spacers with LED flush against PCB. Top of LED should not be above rim (top) of spacer. Center LED inside of spacer.
6. D39, D48 & D55 are yellow LEDs (3-02-0013) and are marked "YELLOW" All other LEDs are green (3-02-0021) and unmarked.
7. Detach BREAKAWAY PCBs along bottom edge and in the inner rectangle after wavesoldering.
8. VERY IMPORTANT: ALL POTS (0-09-1096, 0-09-0018, 0-09-1090) SWITCHES (6-02-0050) AND LED ASSEMBLIES (SEE BELOW) MUST BE PERFECTLY FLUSH (FLAT) AGAINST THE PCB.
9. Board to be wave soldered using Alesis supplied solder fixture.
10. SWITCHCAP LEGEND: "B" in a circle for black circular switchcaps "R" in a circle for red circular switchcaps. "G" in a circle for grey circular switchcaps. "B" in a rectangle for black rectangular switchcaps. "G" in a rectangle for grey rectangular switchcaps.

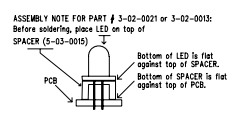
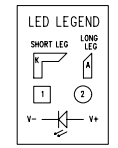

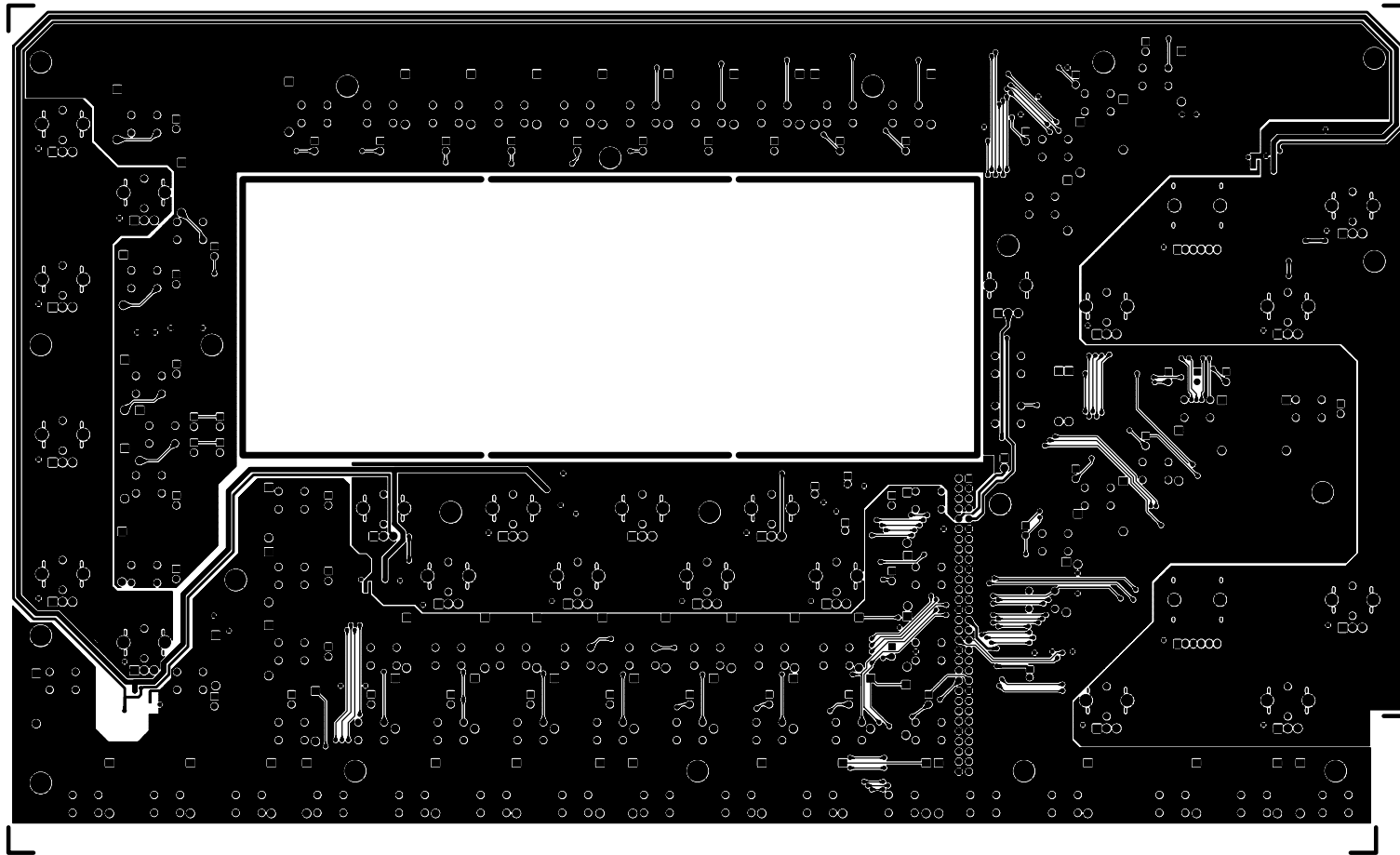

ALESIS 9-40-0207-C "TOPTRACE"

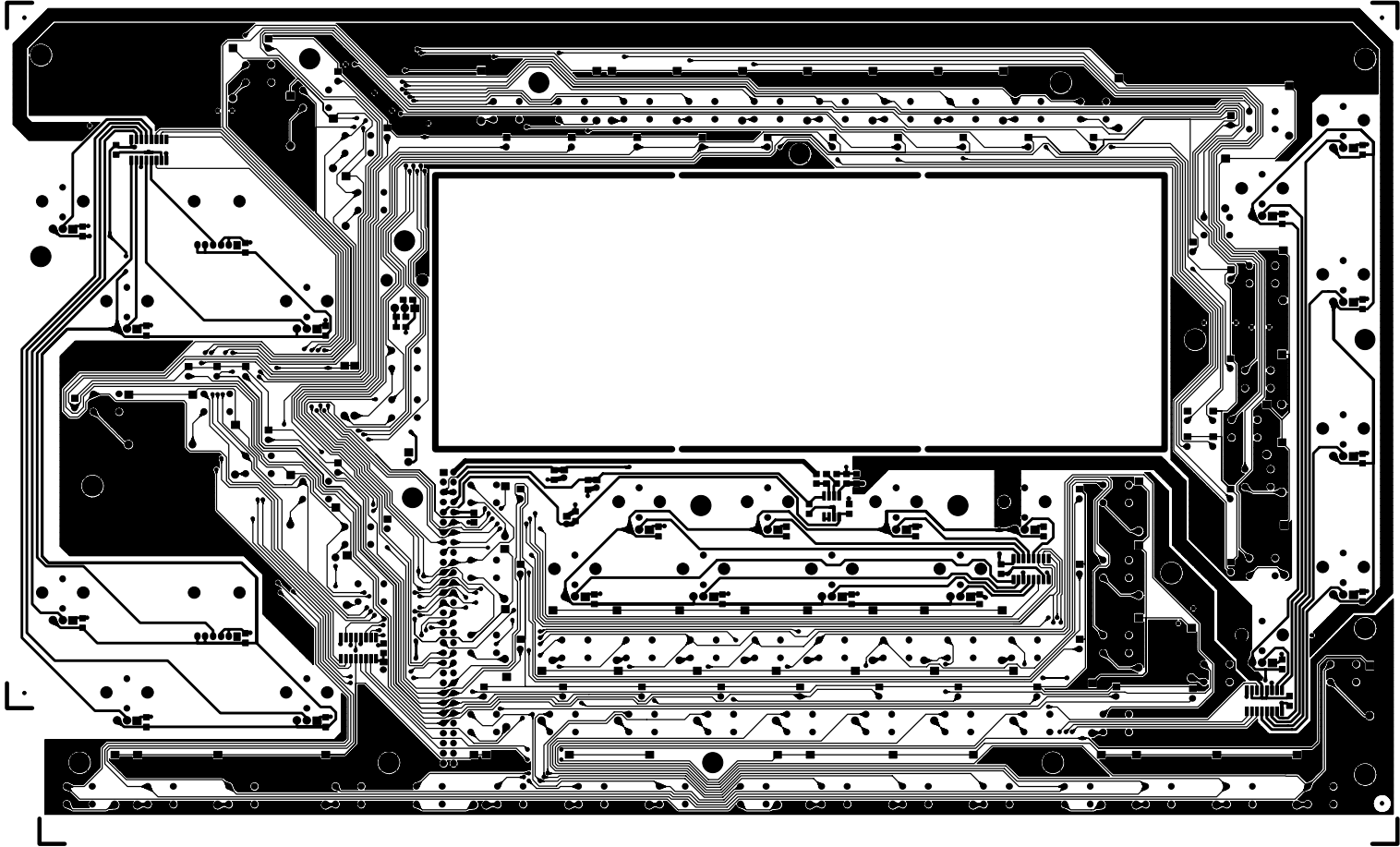

ALESIS 9-40-0207-C "BOTTRACE"





ALESIS ASSEMBLY DRAWING "BOTTOM" 9-79-0207-C



3. Insert J1 (60-pin DIL header) on bottom side and handsolder.

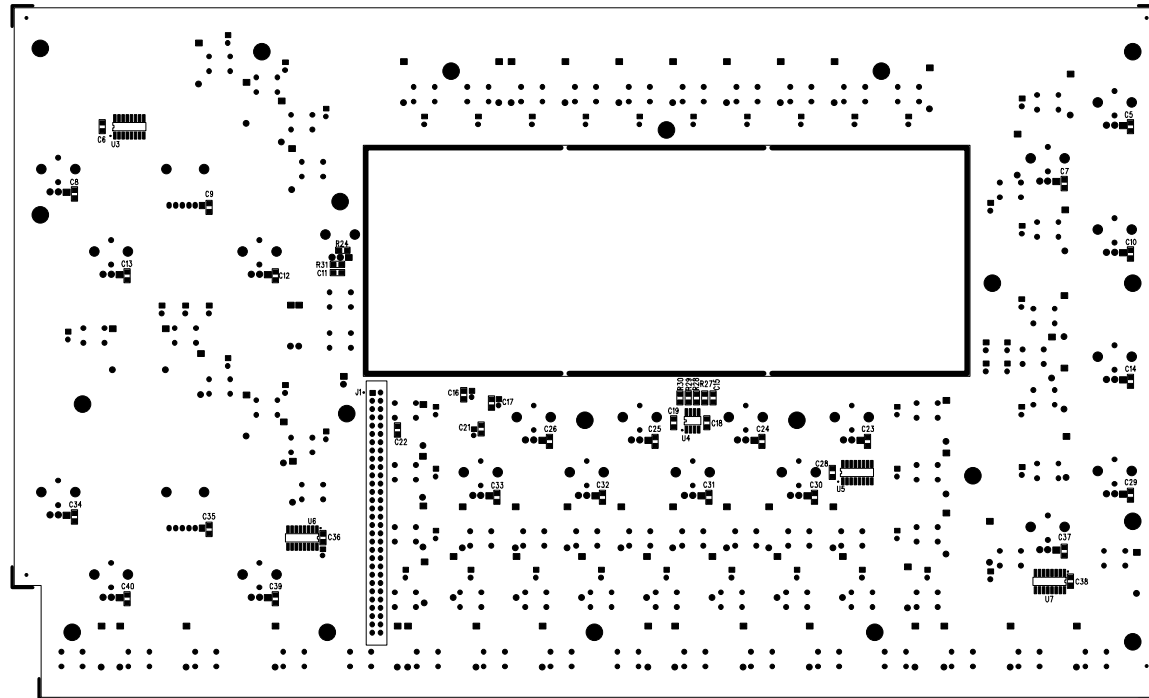

REVISION RECORD			
LTR	ECD NO:	APPROVED:	DATE:
B	A25802	DWS	9/21/00

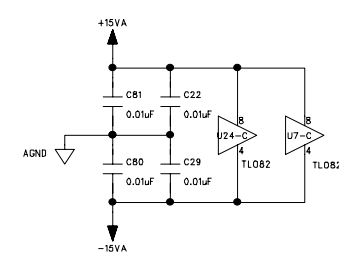
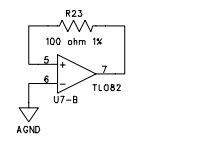
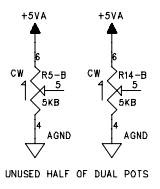
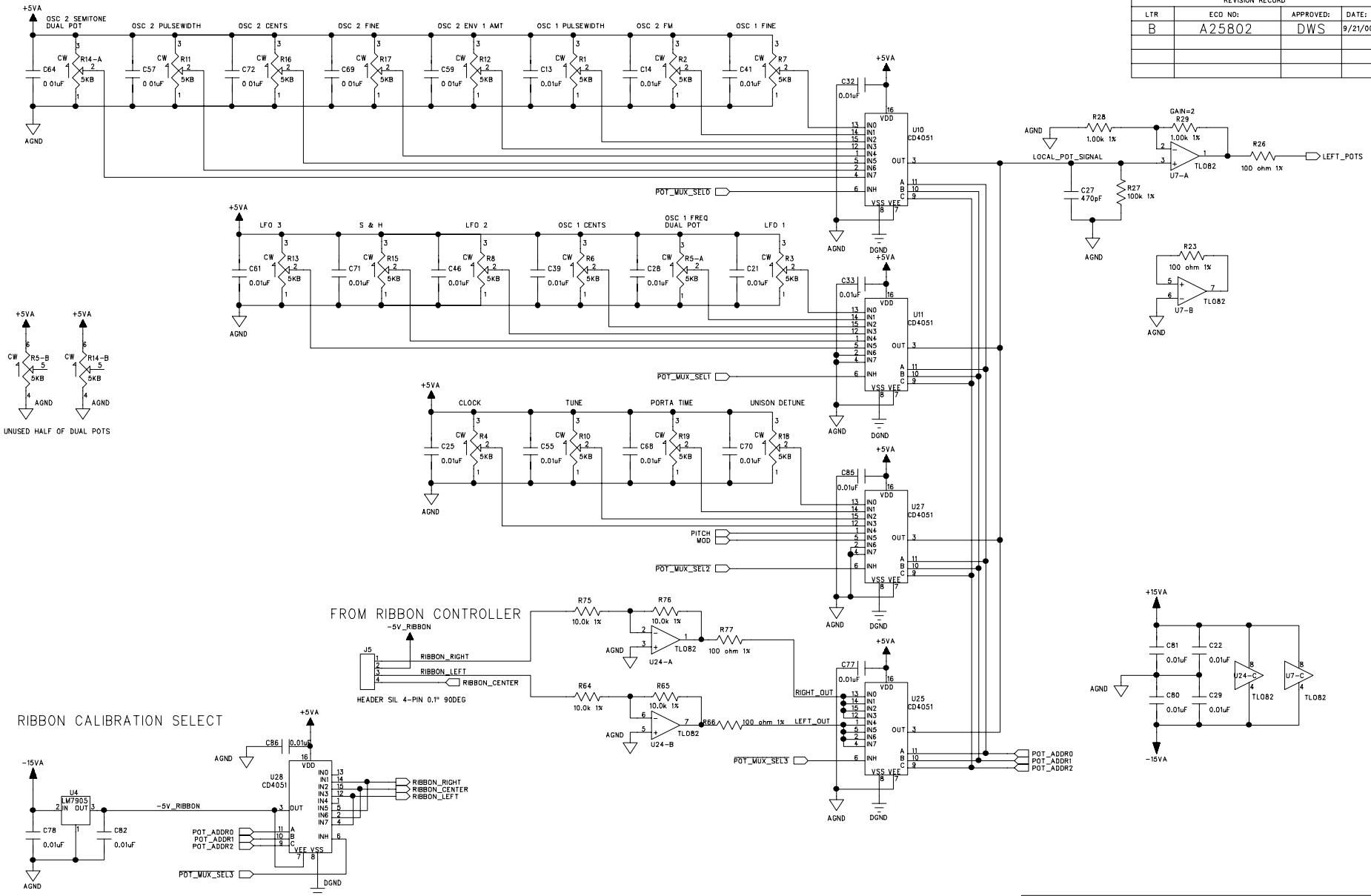

ESTIMATED POWER
 375MA FROM +7V SUPPLY
 12MA FROM +15V SUPPLY
 12MA FROM -15V SUPPLY

COMPANY:	ALESIS		
TITLE:	A6 FRONT PANEL LEFT		
PART NUMBER:	9-40-0206-B	REV:	B
ASSY NUMBER:	9-79-0206	FILENAME:	A6FLB07D.SCH
SCALE:	SHEET 1 OF 4		

DRAWN:	BRIAN SHM	DATED:	7/27/00
RELEASED:	DWS	DATED:	9/21/00

REVISION RECORD			
LTR	ECD NO:	APPROVED:	DATE:
B	A25802	DWS	9/21/00

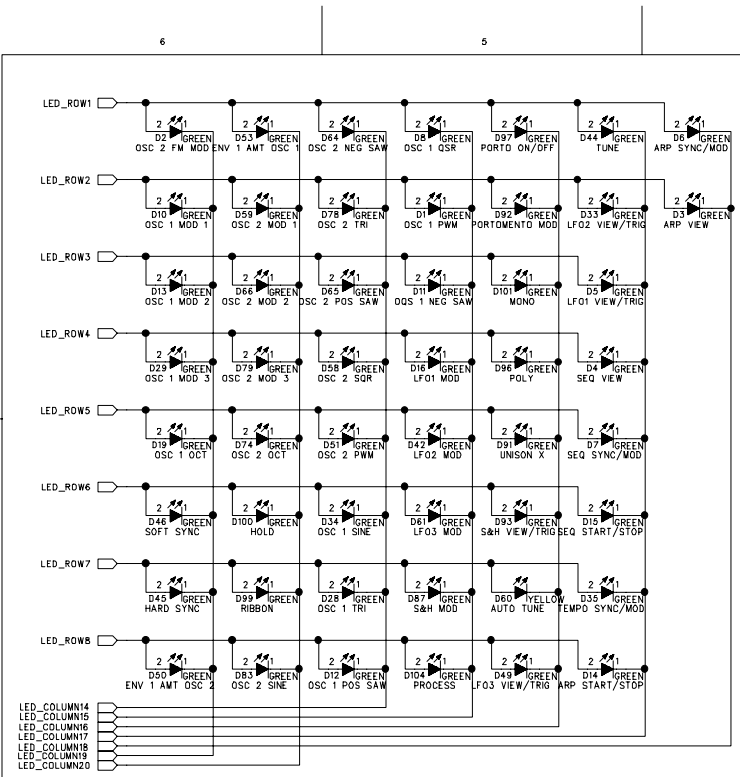

TO PITCH/MOD POTS
HEADER 6-PIN SIL 2mm RA SHROUDED

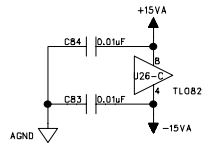
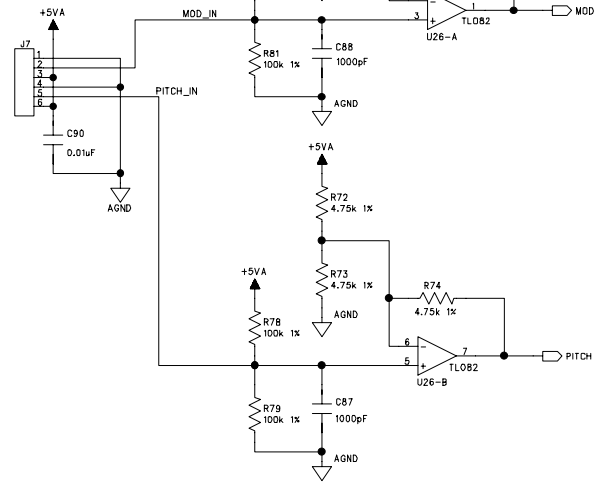

TO ANALOG MAIN PCB

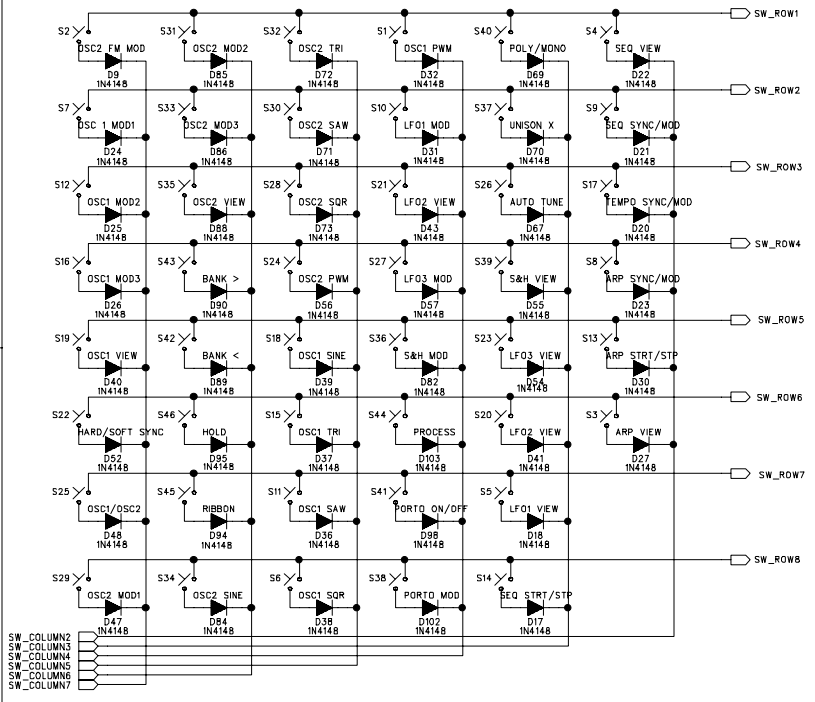
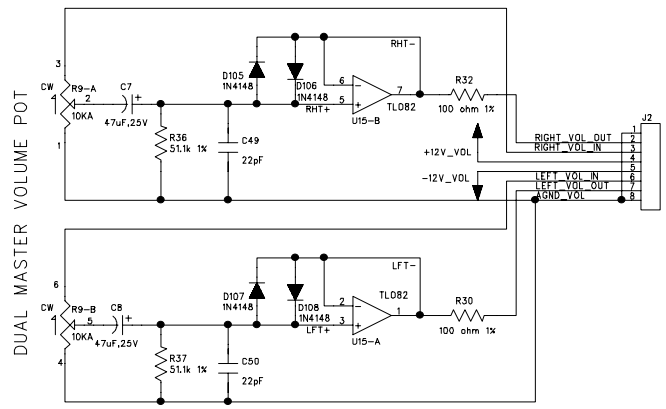

TO PITCH/MOD PCB
Use .1" shrouded connector in BOM

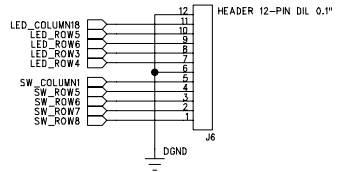

COMPANY:		ALESIS	
TITLE:		A6 FRONT PANEL LEFT	
PART NUMBER:	9-40-0206-B	REV:	B
ASSY NUMBER:	9-79-0206		
FILENAME:	A6FLB07A.SCH		
DRAWN:	BRIAN SHIM	DATED:	7/27/00
RELEASED:	DWS	DATED:	9/21/00
SCALE:			SHEET 2 OF 4

REVISION RECORD			
LTR	ECD NO:	APPROVED:	DATE:
B	A25802	DWS	9/21/00

TO DIGITAL MAIN PCB

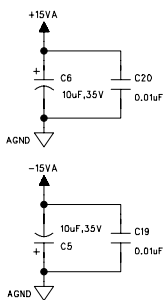
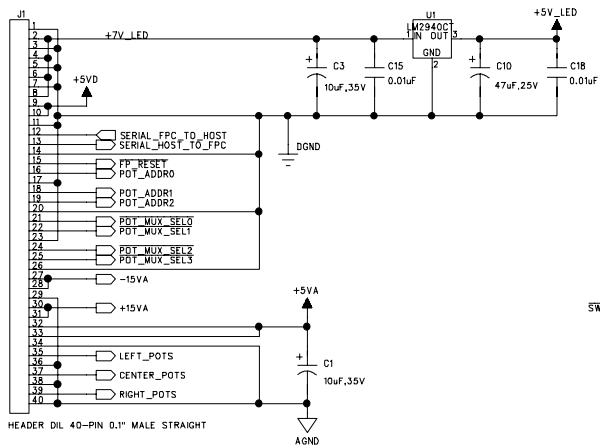

TO CENTER AND RIGHT FP PCBs

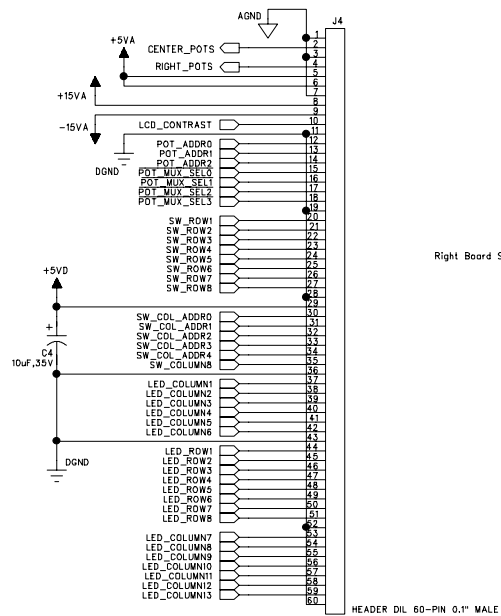

Right Board S/L

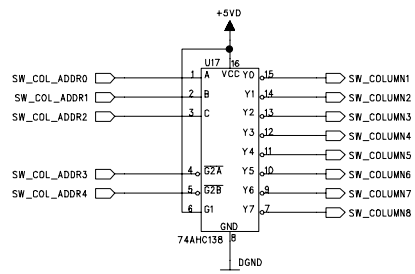
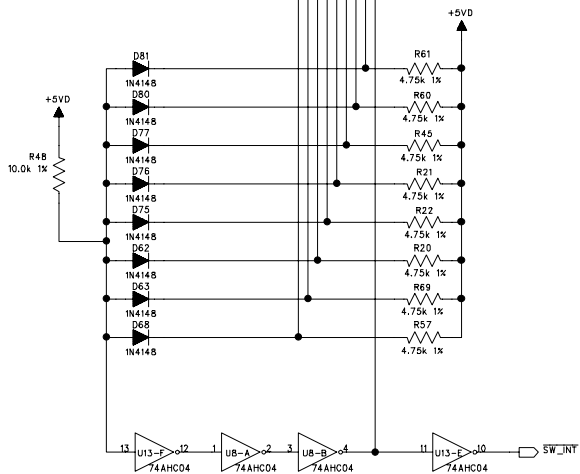
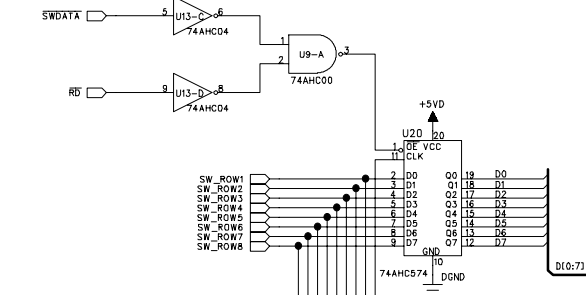

COMPANY:	ALESIS		
TITLE:	A6 FRONT PANEL LEFT		
PART NUMBER:	9-40-0206-B	REV:	B
ASSY NUMBER:	9-79-0206		
FILENAME:	A6FLB07A.SCH		
SCALE:		SHEET:	3 OF 4

DRAWN:	BRIAN SHIM	DATED:	7/27/00
RELEASED:	DWS	DATED:	9/21/00

REVISION RECORD			
LTR	ECD NO:	APPROVED:	DATE:
B	A25802	DWS	9/21/00

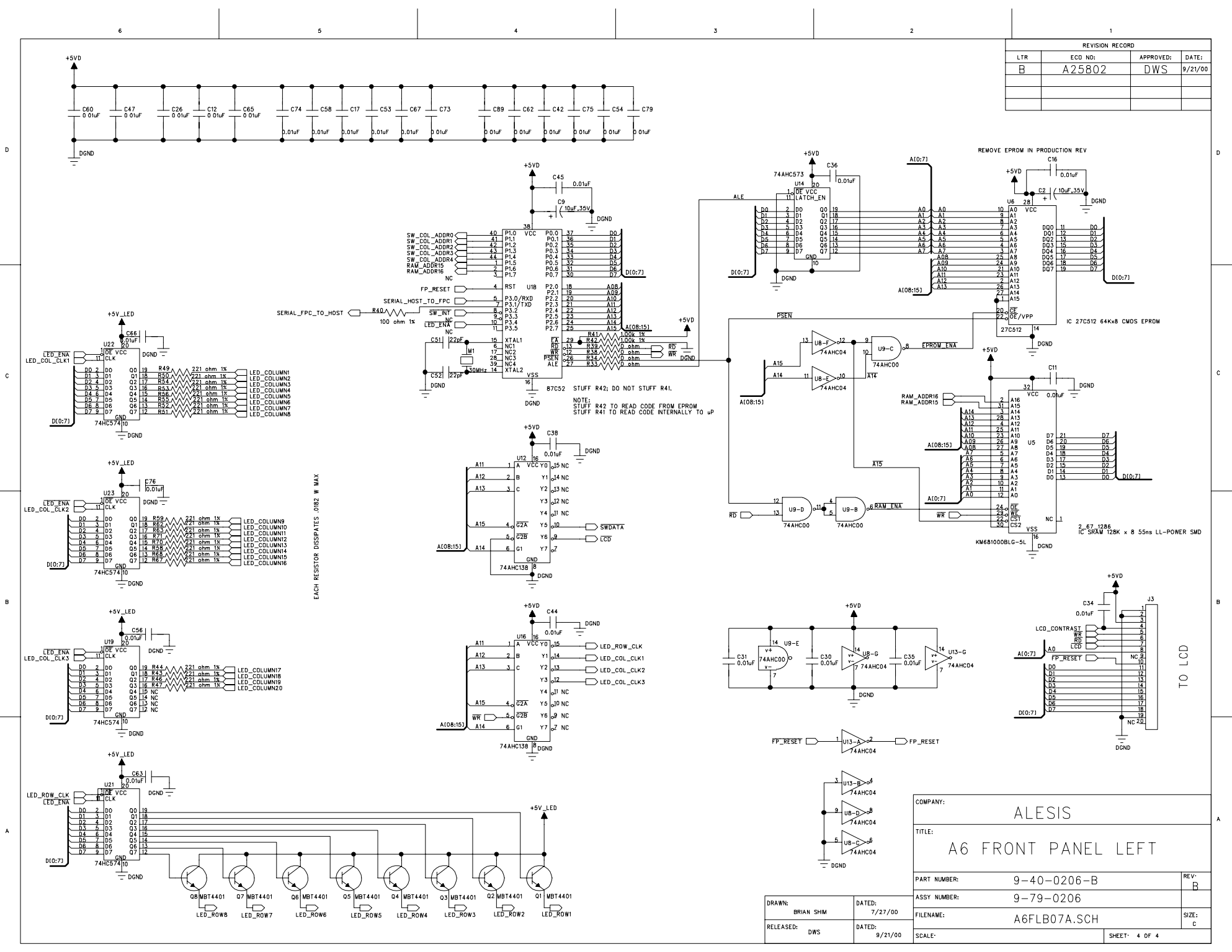

EACH RESISTOR DISSIPATES .082 W MAX

COMPANY:	ALESIS		
TITLE:	A6 FRONT PANEL LEFT		
PART NUMBER:	9-40-0206-B	REV:	B
ASSY NUMBER:	9-79-0206	FILENAME:	A6FLB07A.SCH
SCALE:		SHEET:	4 OF 4

DRAWN:	BRIAN SHIM	DATED:	7/27/00
RELEASED:	DWS	DATED:	9/21/00

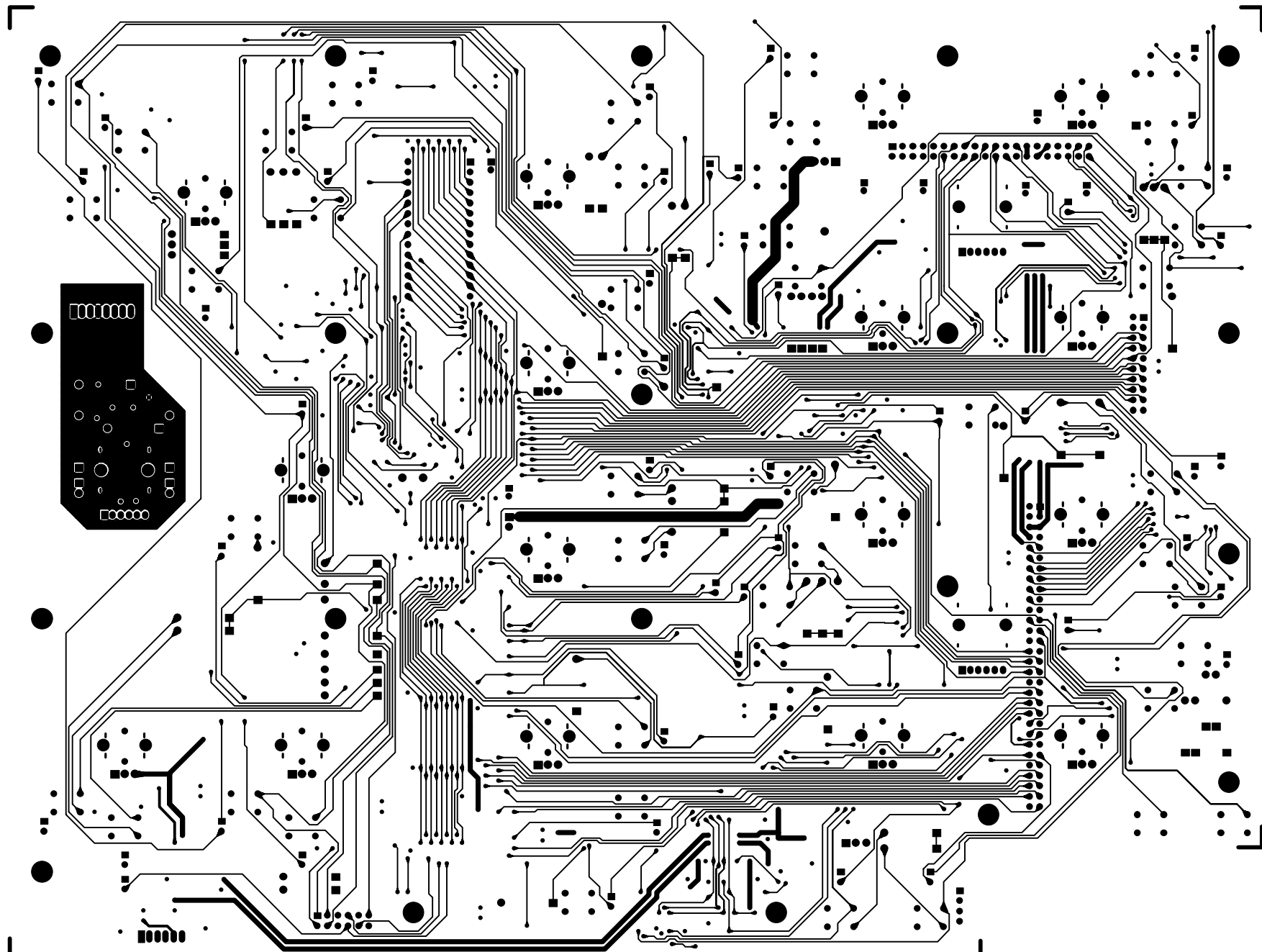

ALESIS 9-40-0206-B "TOPTRACE"

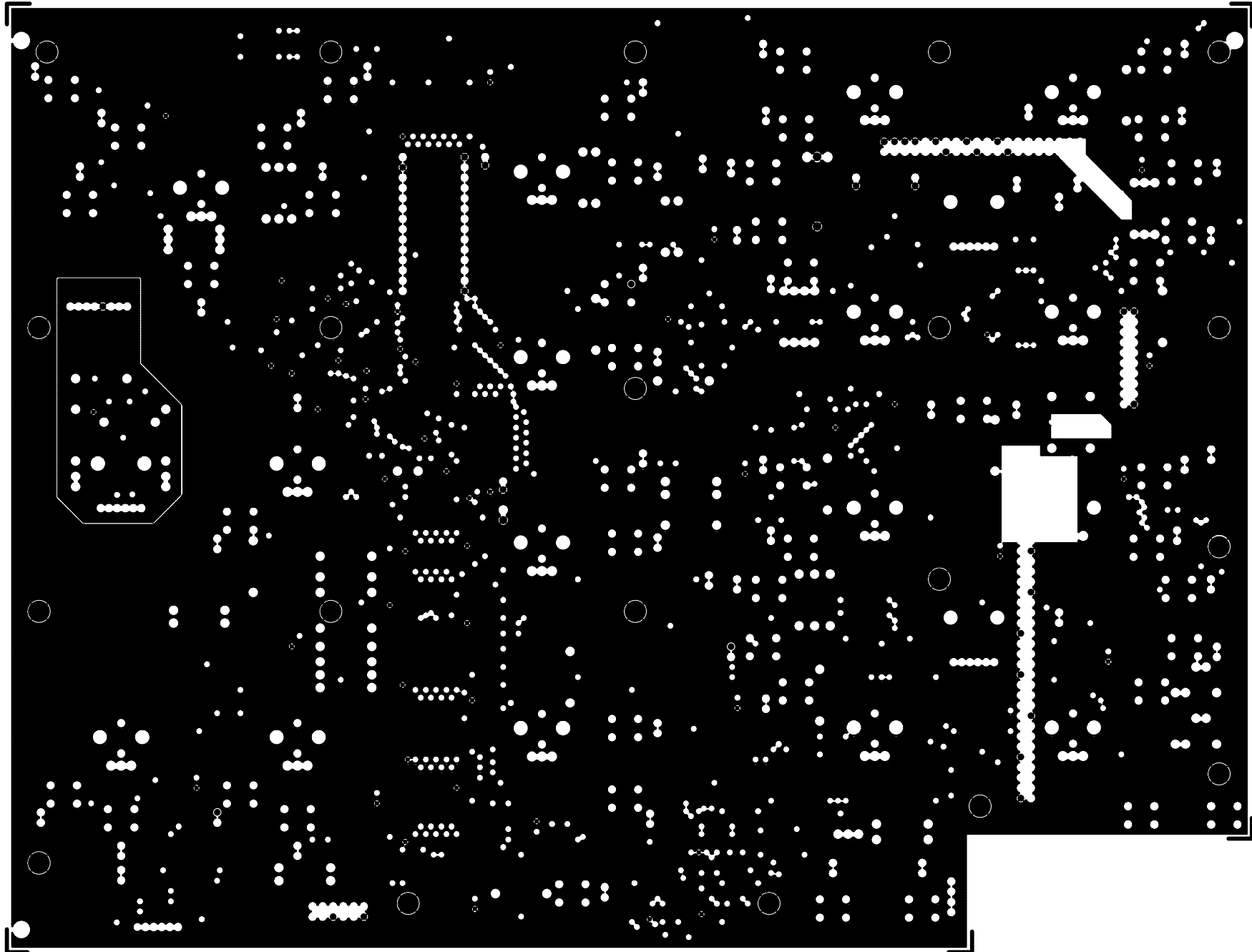

ALESIS 9-40-0206-B "GNDPLANE LAYER 2"



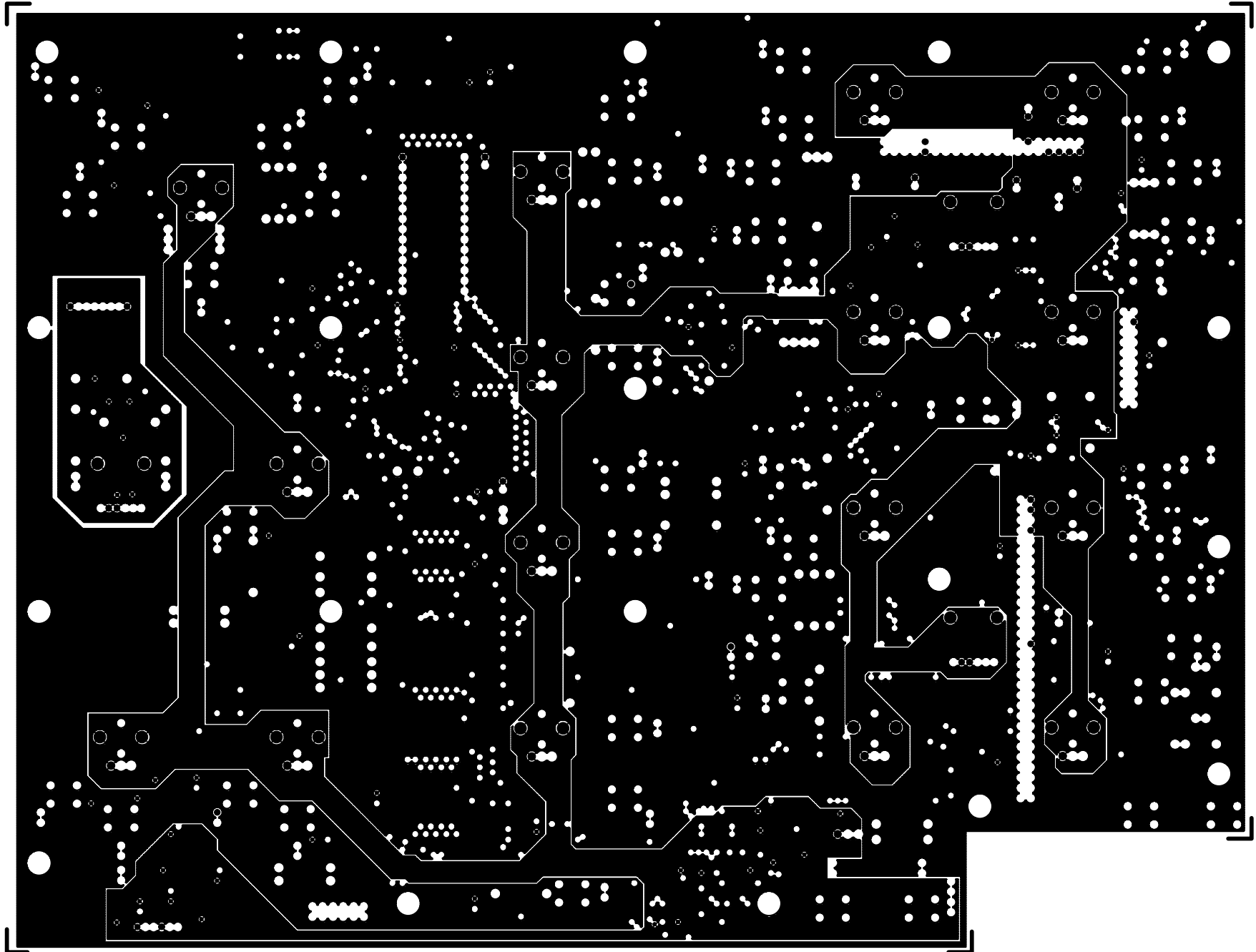

ALESIS 9-40-0206-B "PWRPLANE LAYER 3"

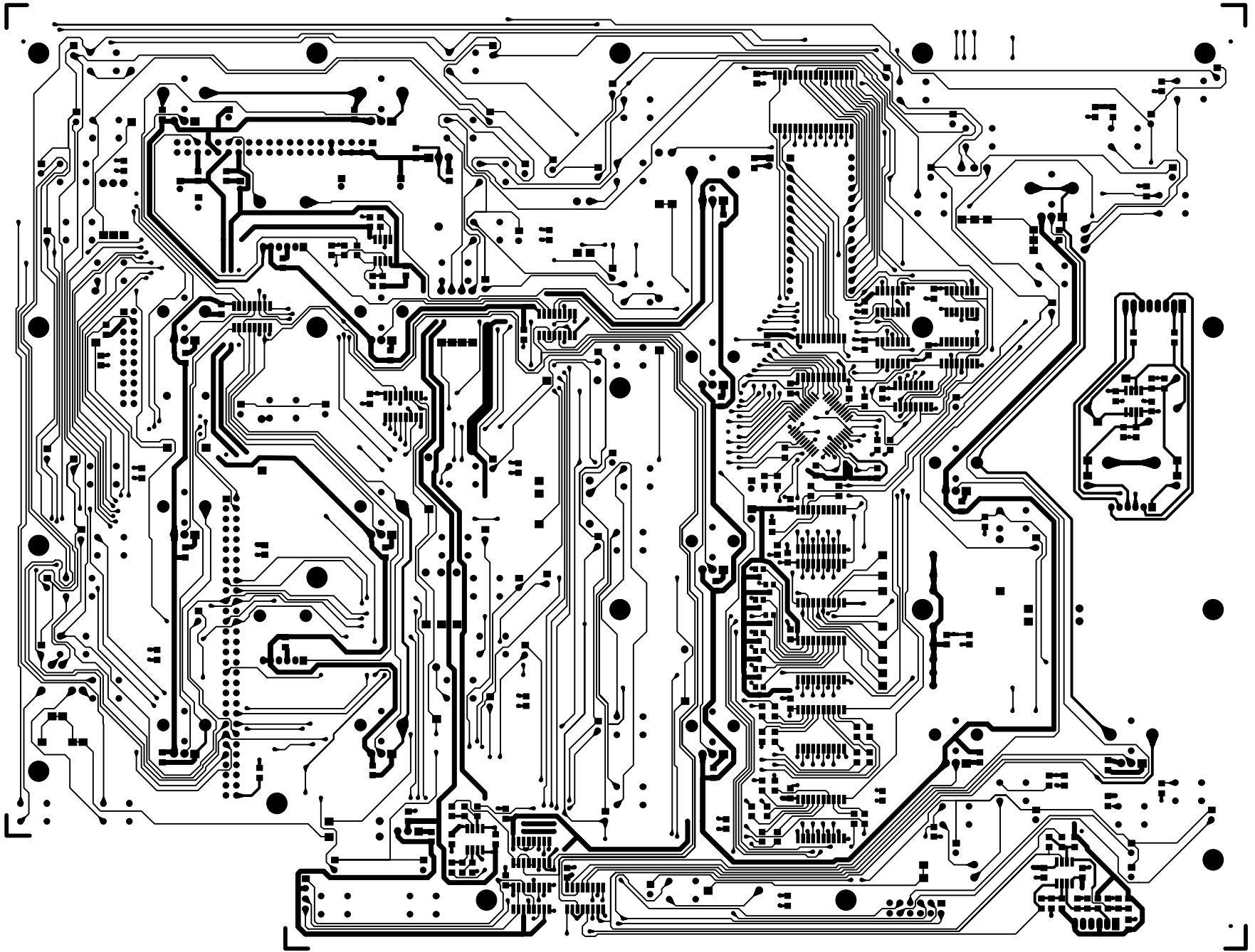

ALESIS 9-40-0206-B "BOTTRACE"



⊕ ALESIS BOTTOM ASSEMBLY DRAWING 9-79-0206-B ⊕

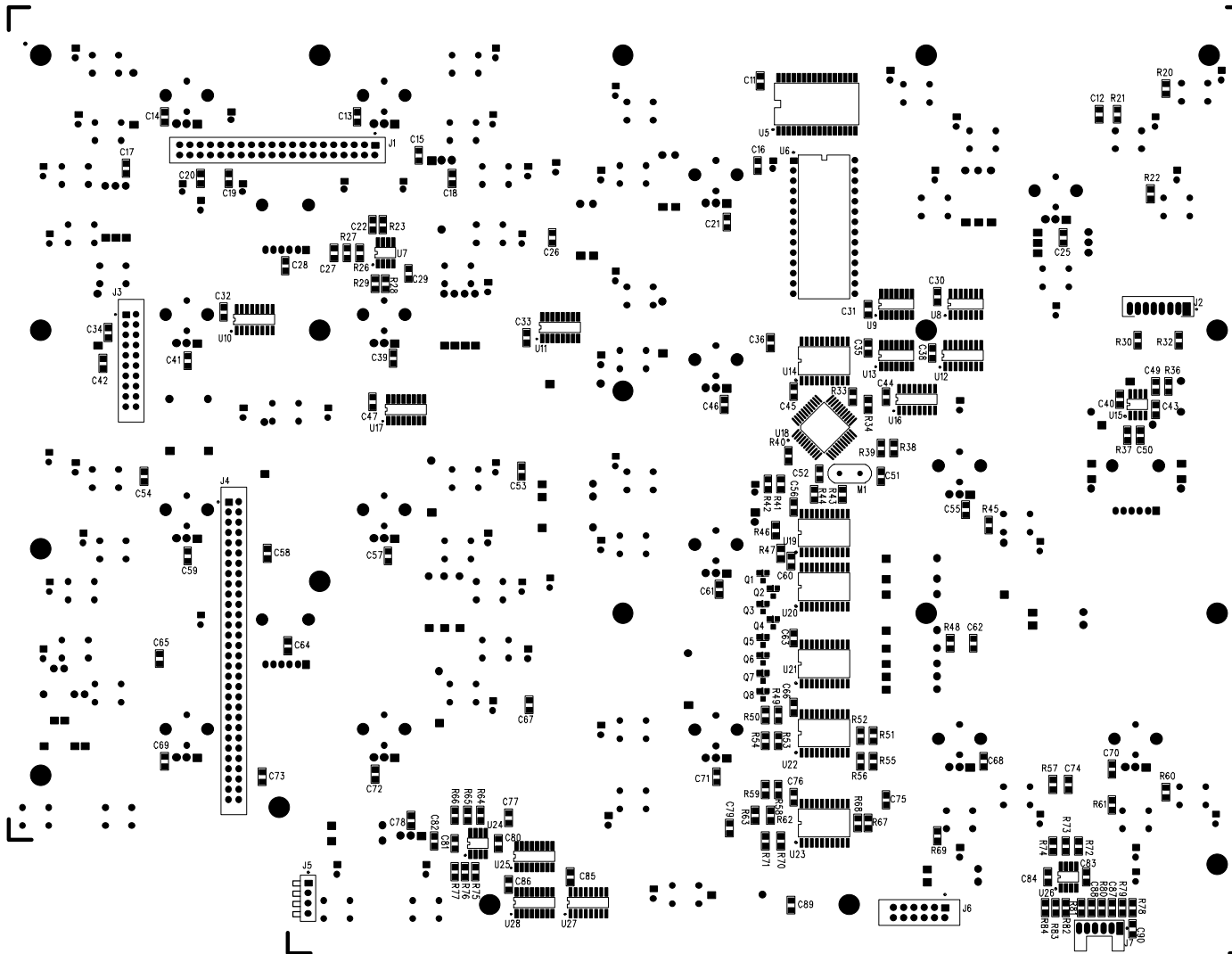

1. Mount the following parts on the bottomside of the PCB and hand solder on the topside: Headers J1-7 (4-14-4000, 4-15-0804, 4-14-1120, 4-14-6000, 4-15-0404, 4-14-0012, 4-15-2106) crystal M1 (7-01-0028) socket U6 (4-06-0025) and hand solder.
2. Right angle header J5 (4-15-0404) should be mounted with pins pointing toward board edge.



REVISION RECORD			
LR	ECO NO	APPROVED	DATE

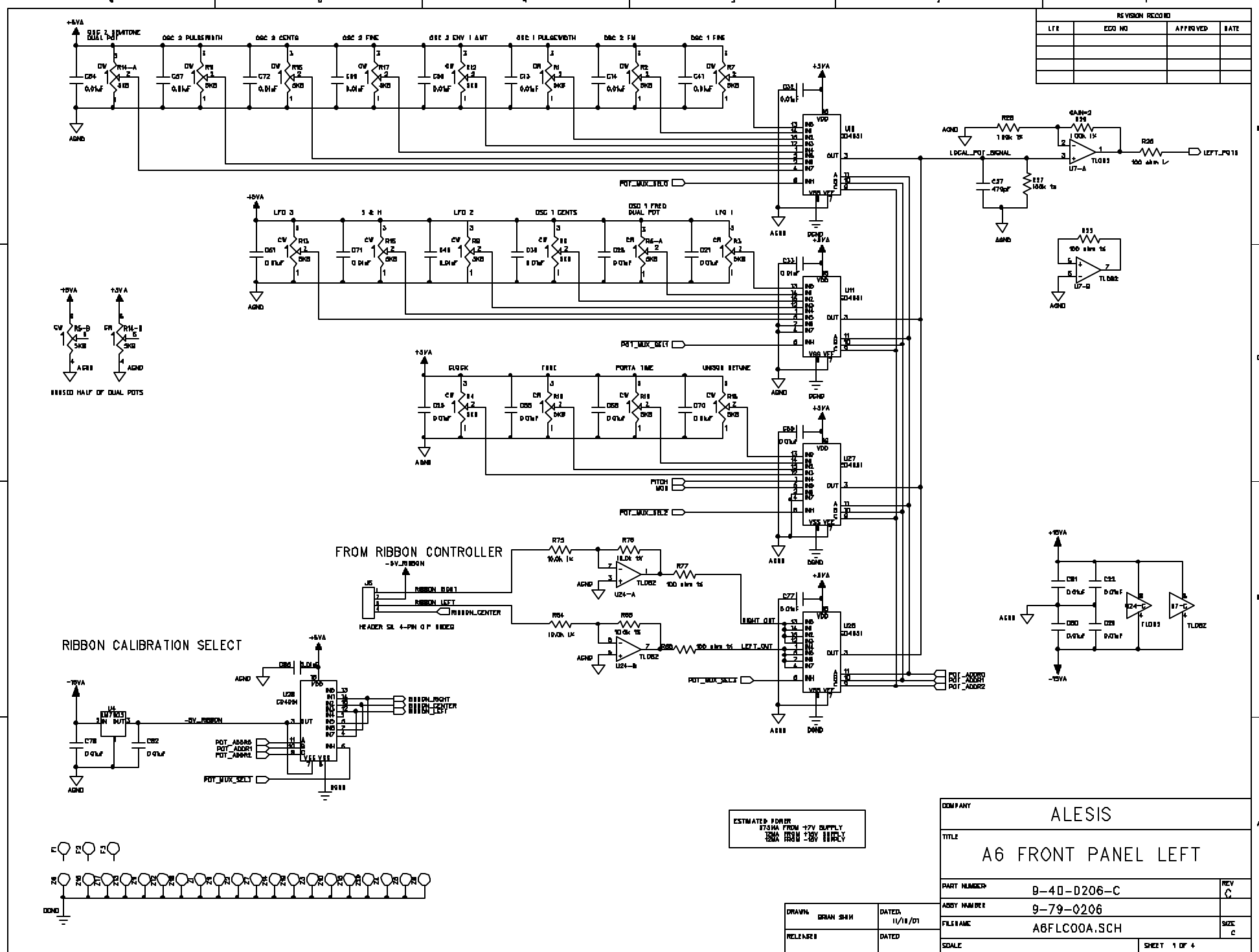

RIBBON CALIBRATION SELECT

FROM RIBBON CONTROLLER

ESTIMATED POWER
 175mA FROM +5V SUPPLY
 200mA FROM +12V SUPPLY

COMPANY		ALESIS	
TITLE			
A6 FRONT PANEL LEFT			
PART NUMBER			REV
B-40-D206-C			C
ASSEMBLY NUMBER			SIZE
9-79-0206			C
FILENAME			SCALE
A6FLC00A.SCH			
DRAWN			DATED
BRAN SHM			11/18/01
RELEASED			DATED
			SHEET 1 OF 4

REVISION RECORD			
LR	ECO NO	APPROVED	DATE

TO DIGITAL MAIN PCB

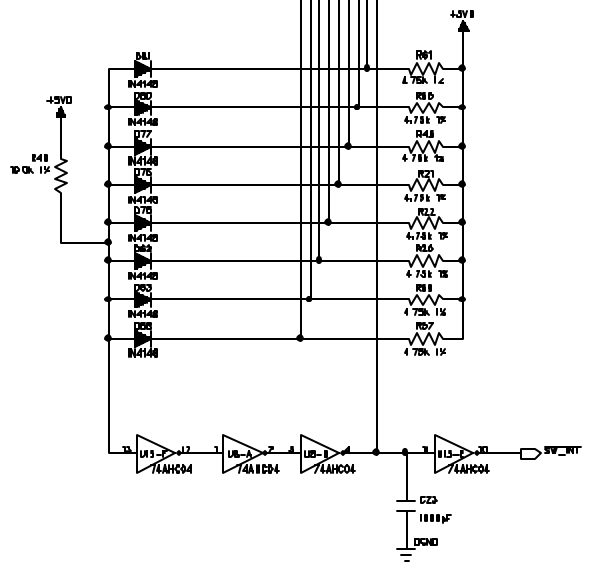
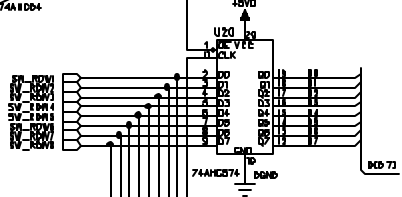
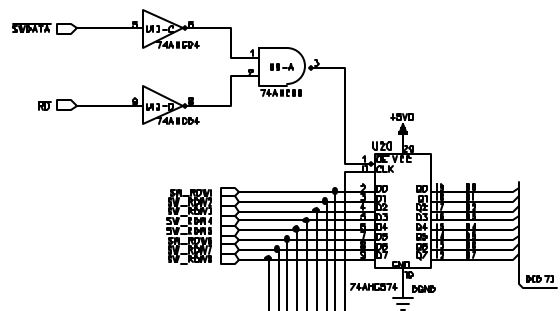
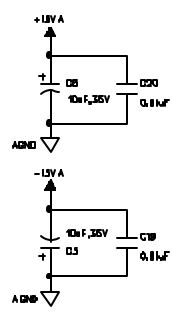
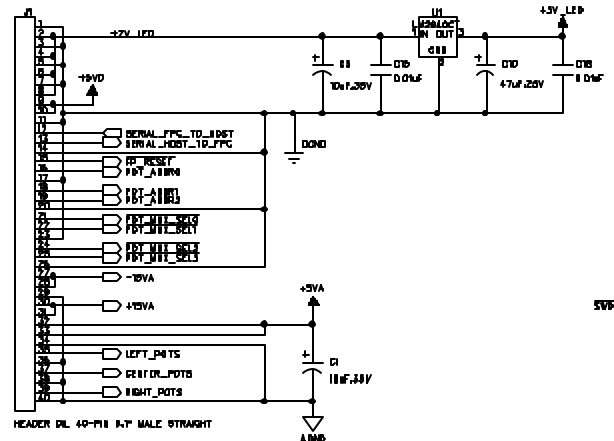

TO CENTER AND RIGHT FP PCBs

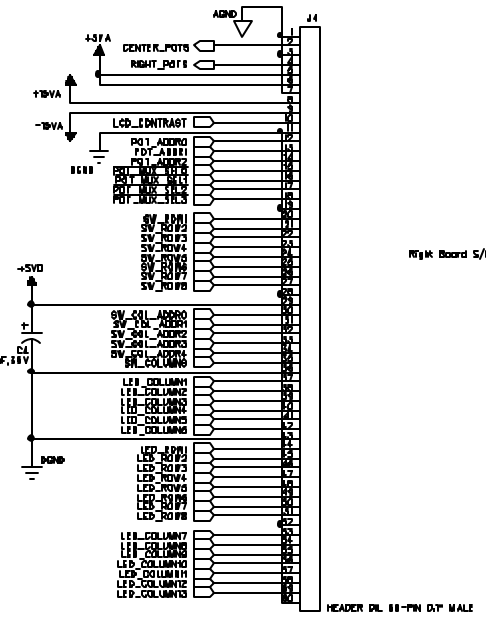

Right Board S/L

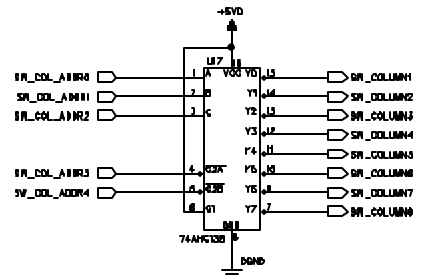

COMPANY	ALEXIS		
TITLE	A6 FRONT PANEL LEFT		
PART NUMBER	9-40-0206-C	REV	
ASBY NUMBER	9-79-0206		
FILENAME	A6FLC00A.SCH		SIZE
SCALE			SHEET 3 OF 4

DRAWN	ORIAN SHM	DATED	11/18/01
RELEASED		DATED	

REVISION RECORD			
LR#	ECO NO	APPROVED	DATE

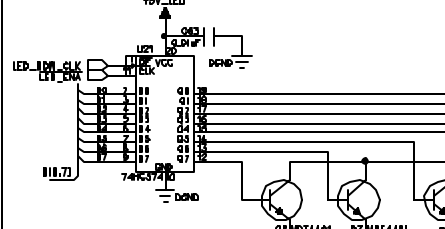
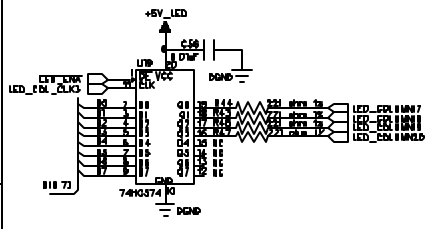
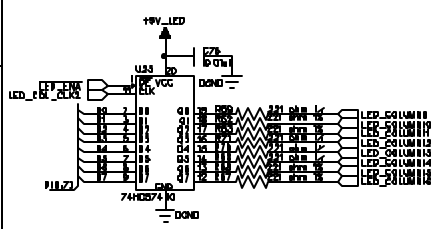
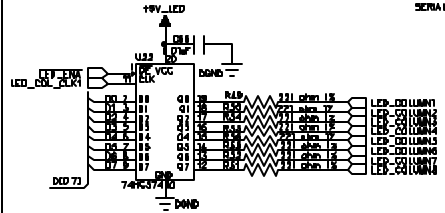
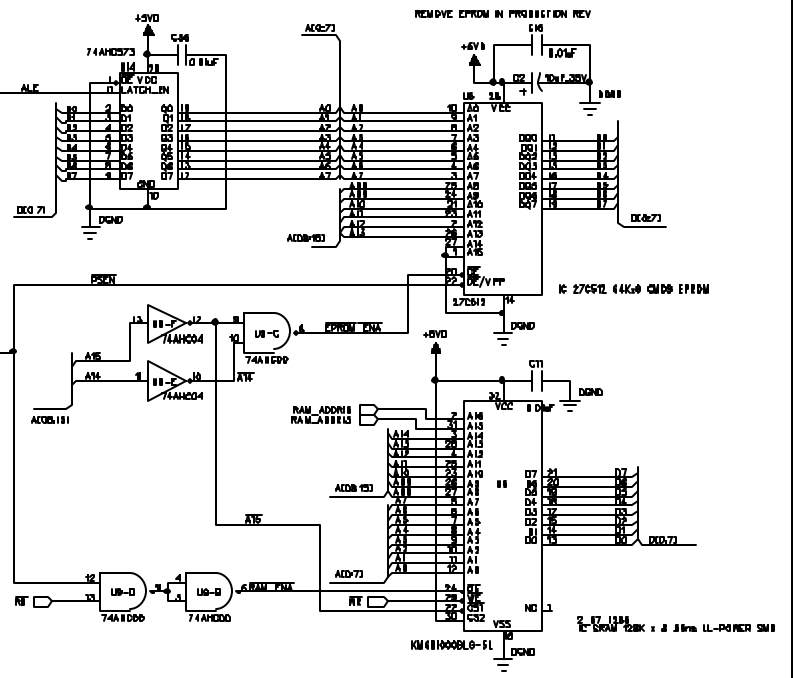
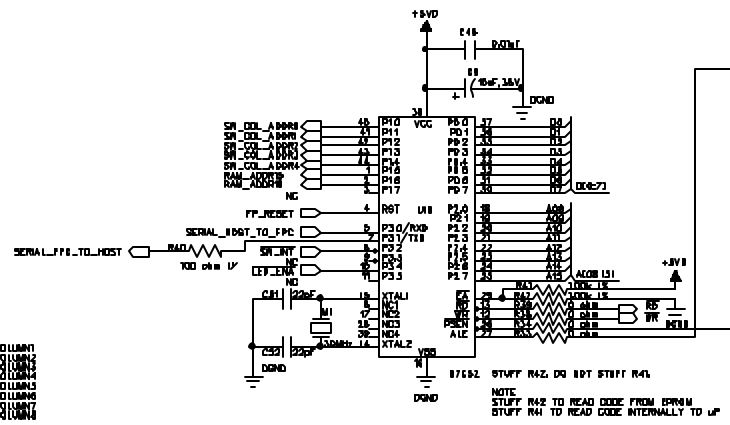
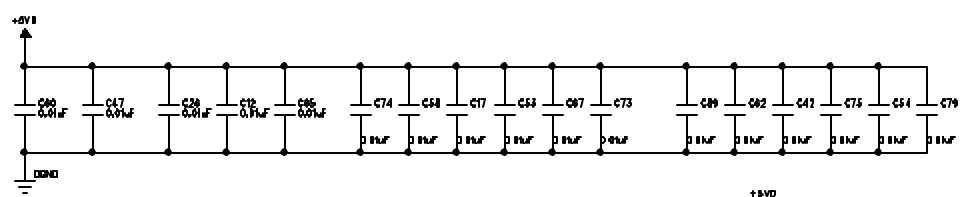

DATA BUSLINE INDICATES IEEE V MAX

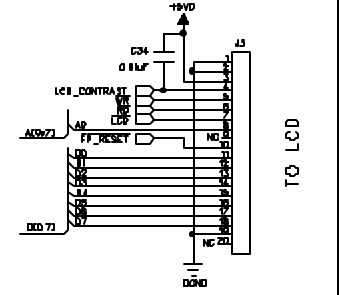
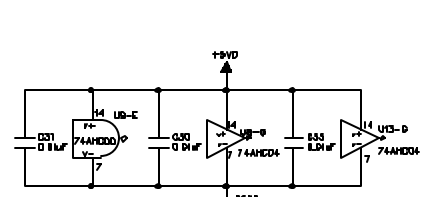
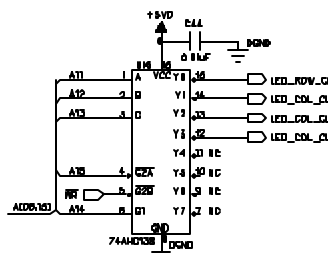
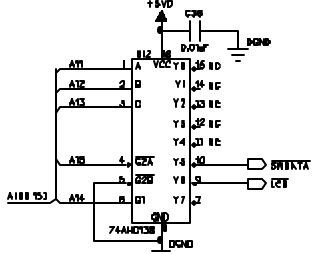

COMPANY	ALEXIS		
TITLE	A6 FRONT PANEL LEFT		
PART NUMBER	9-40-0206-C	REV	C
ASBY NUMBER	9-79-0206	SCALE	
FILE NAME	A6FLC00A.SCH		SIZE
SCALE		SHEET	4 OF 4

DRAWN	BRUN GHW	DATED	7/21/00
RELEASED		DATED	

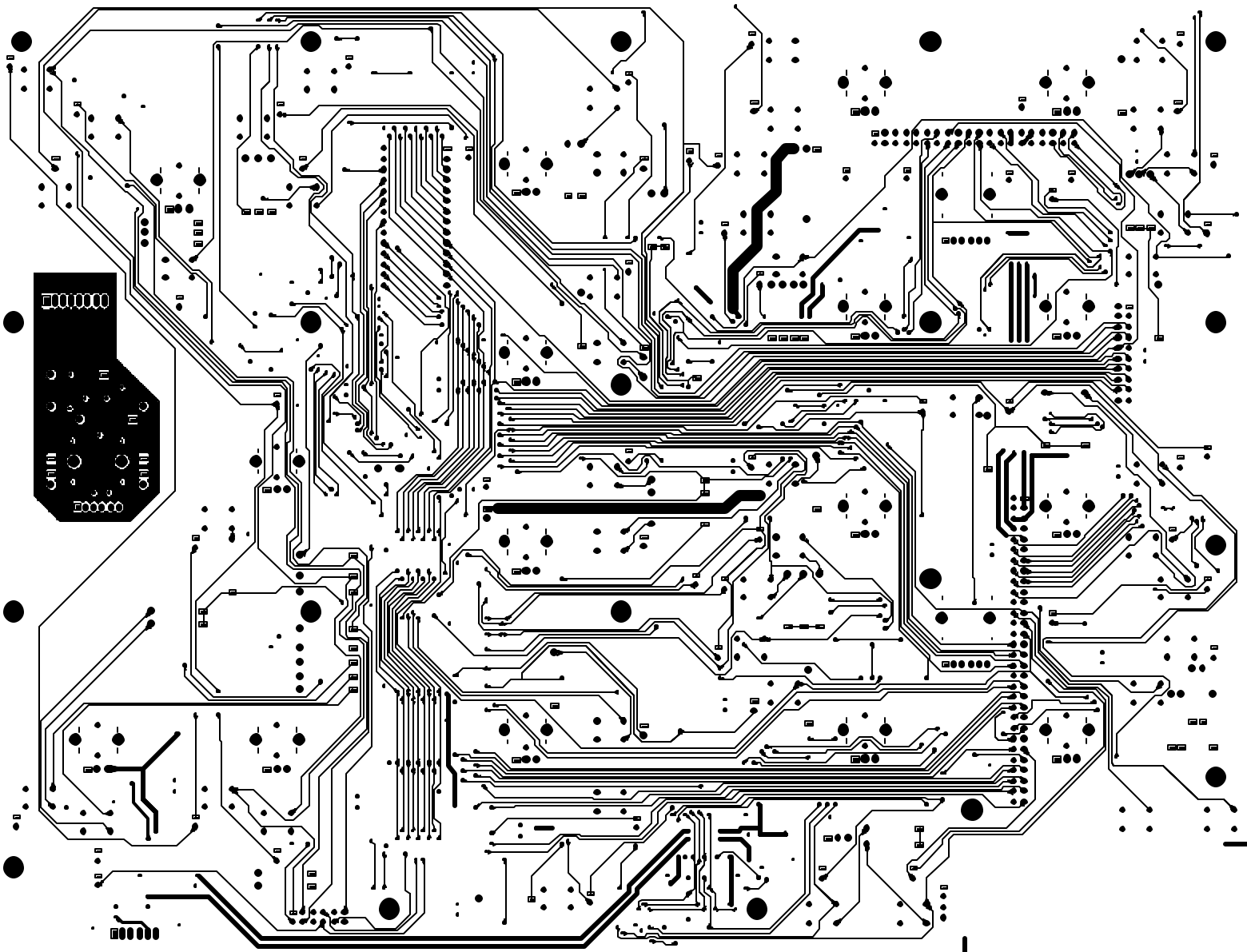

ALESIS 9-40-0206-C "TOPTRACE"



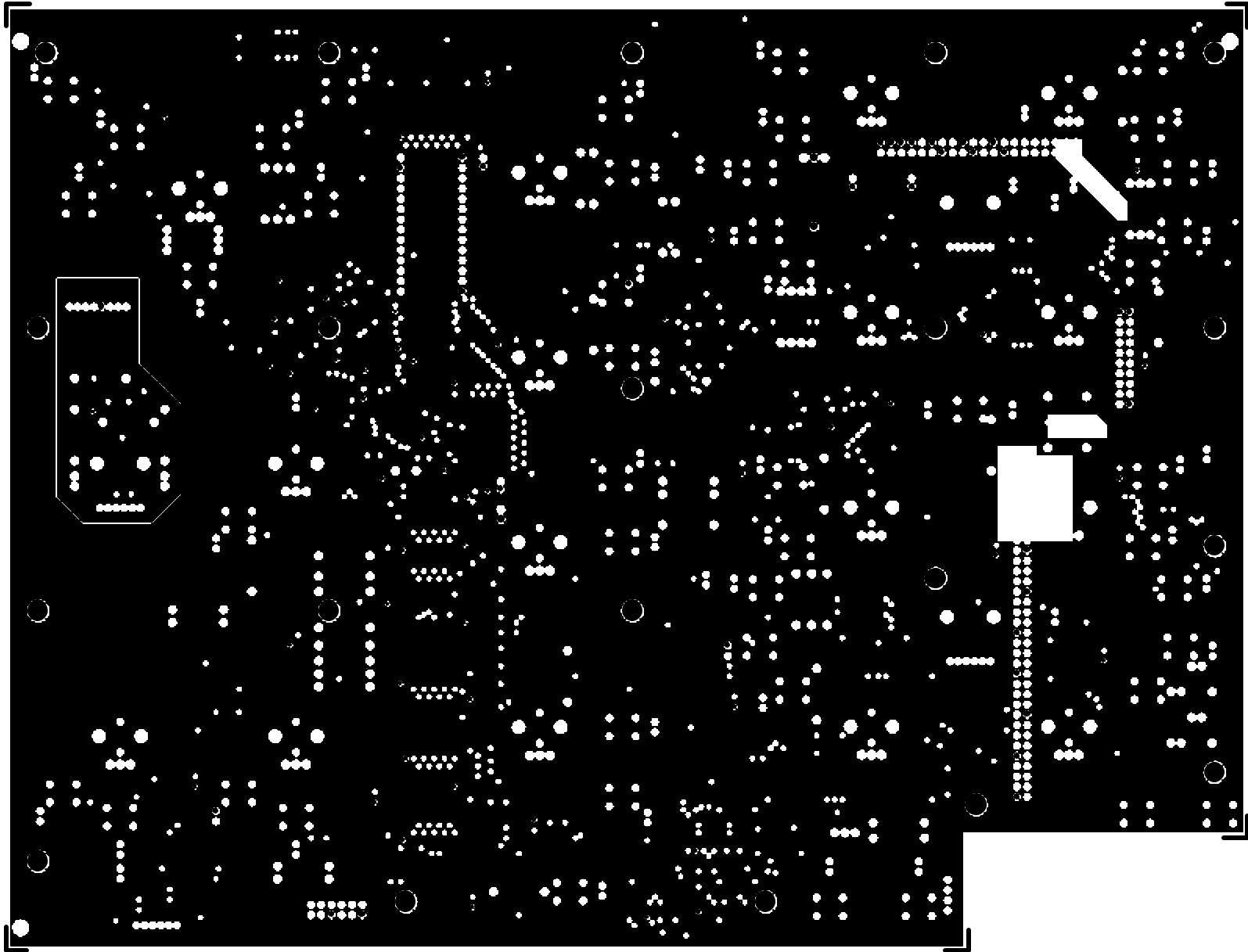

ALESIS 9-40-0206-C "GNDPLANE LAYER 2"



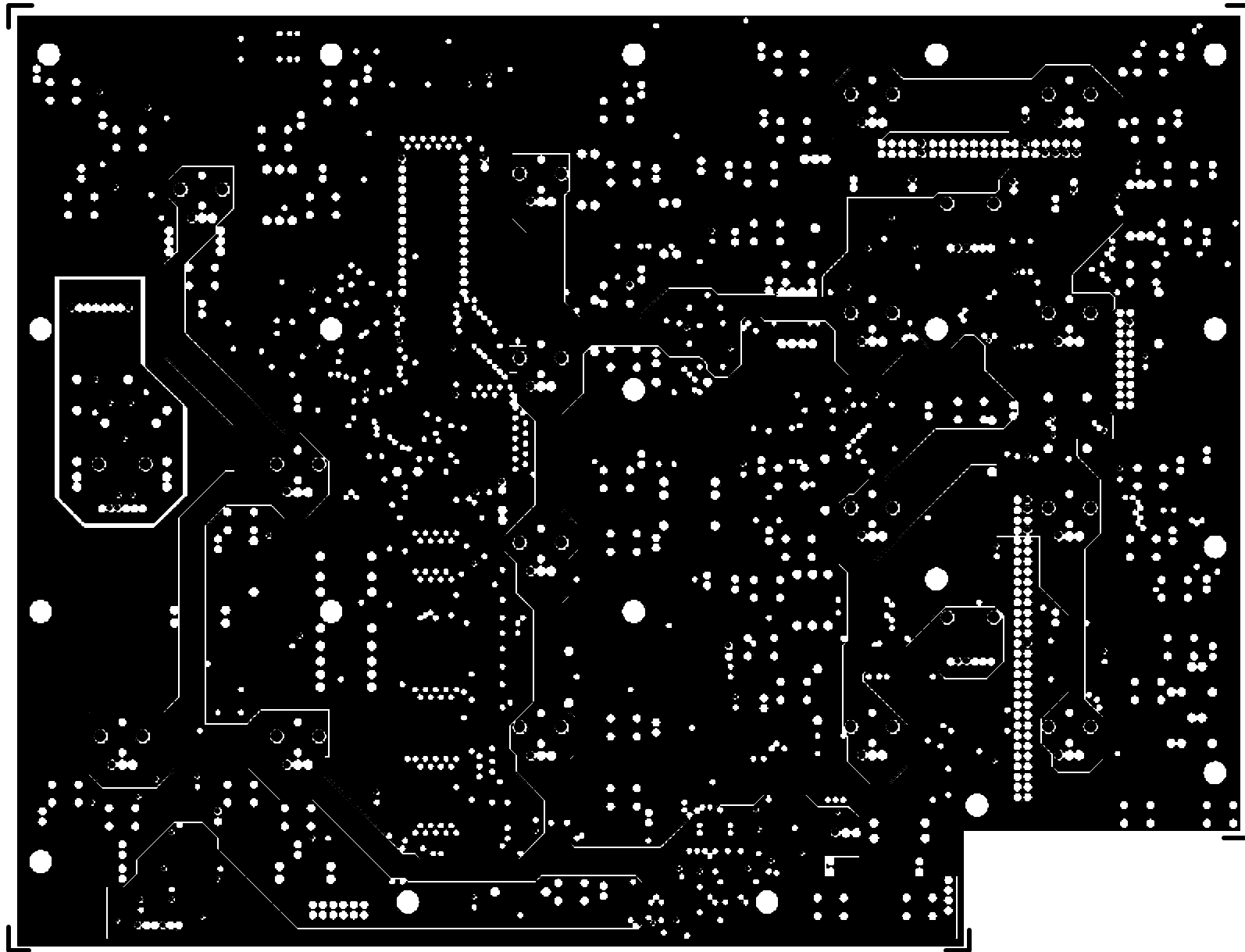

ALESIS 9-40-0206-C "PWRPLANE LAYER 3"

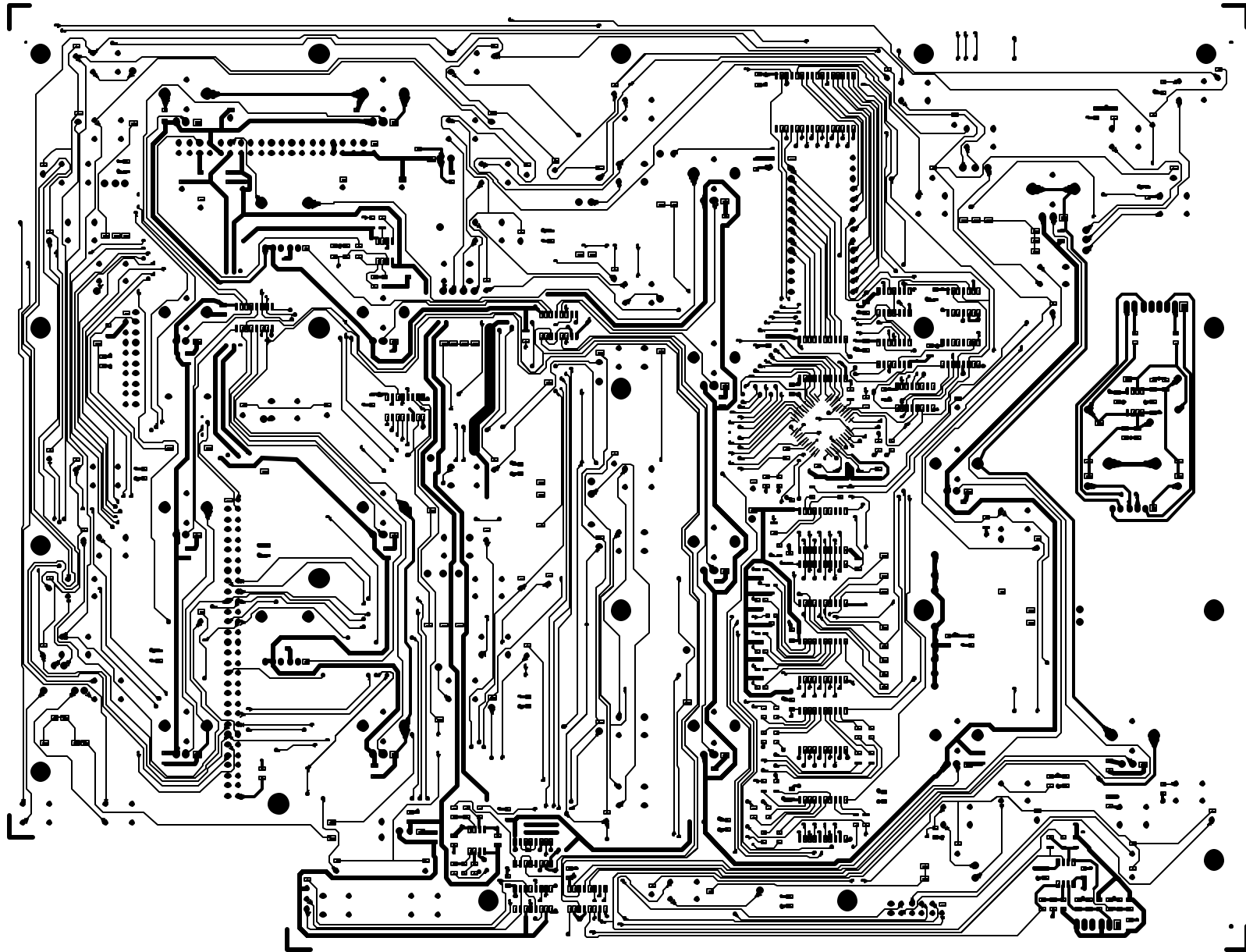

ALESIS 9-40-0206-C "BOTTRACE"



ALISIS BOTTOM ASSEMBLY DRAWING 9-79-0206-C

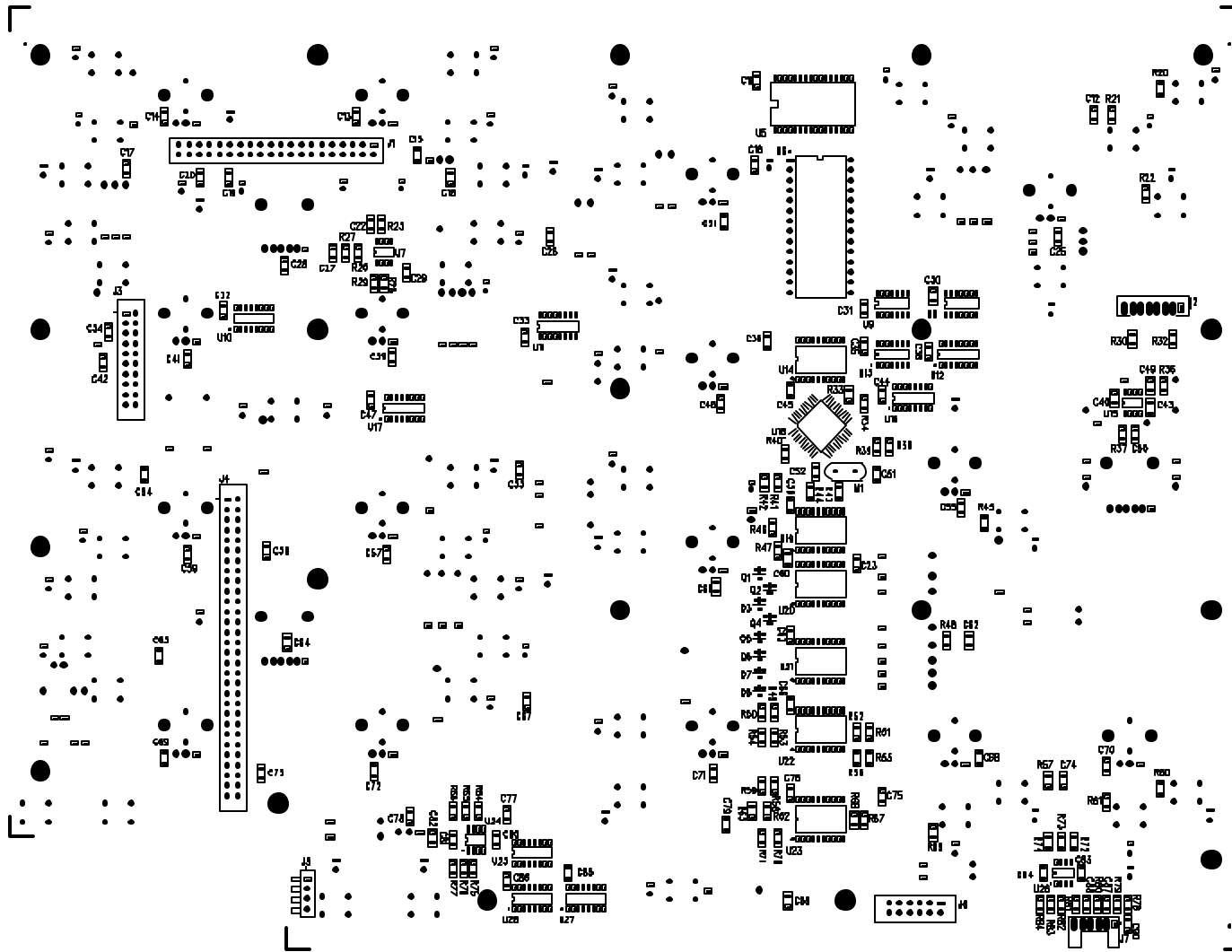

1. Mount the following parts on the bottomside of the PCB and hand solder of the leads: Headers J1-7 (4-14-4000, 4-14-0001, 4-14-011, 4-14-6000, 4-10-6404, 4-14-001), 4-10-2228 crystal M1 (7-01-0020), socket U6 (4-05-1134) and hand solder.
2. Right angle header J0 (4-10-1444) should be mounted with pins pointing toward board edge.

REVISION RECORD			
LTR	ECD NO:	APPROVED:	DATE:
B	A25802	DWS	9/13/00

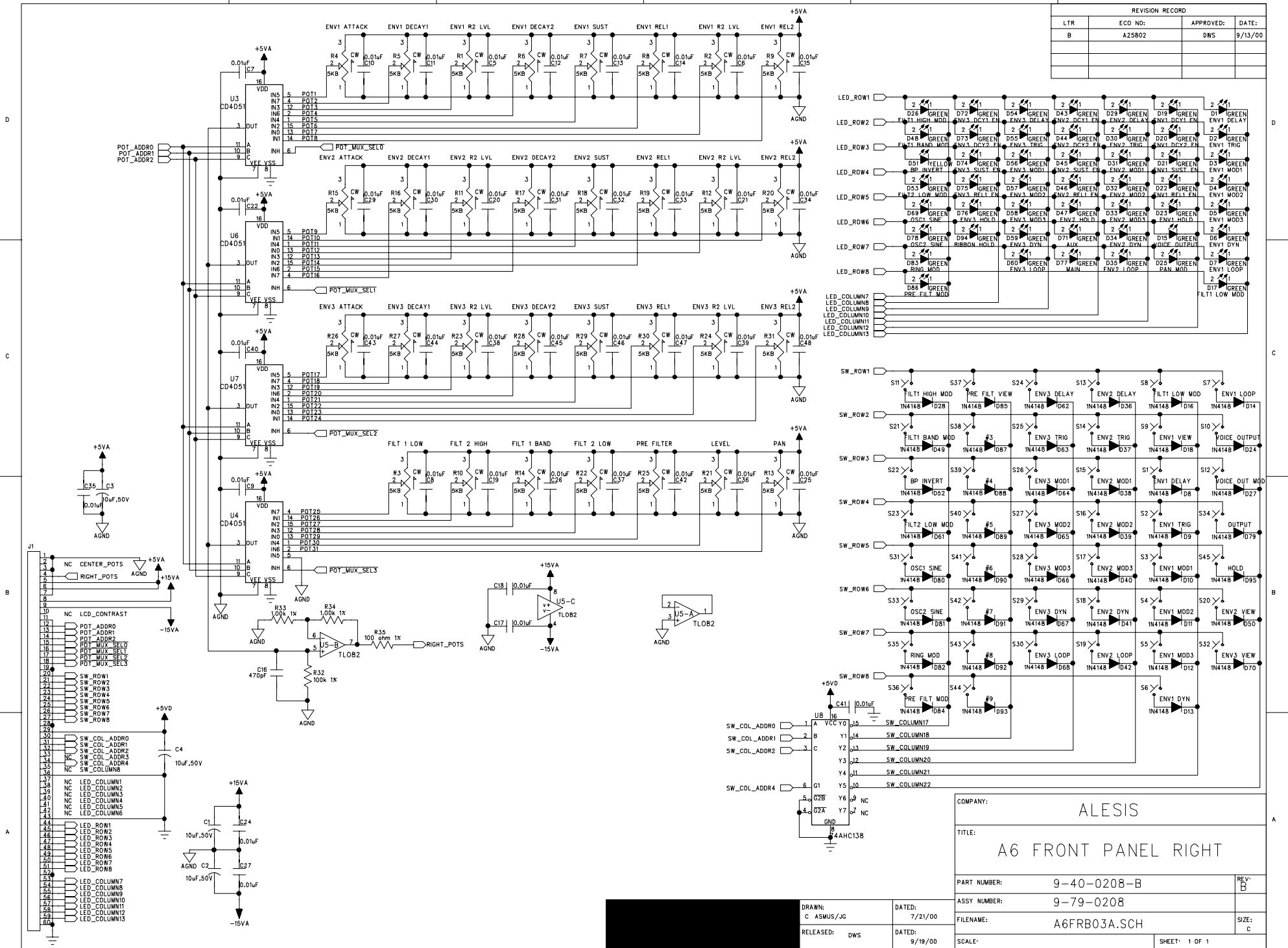

COMPANY:	ALESIS		
TITLE:	A6 FRONT PANEL RIGHT		
PART NUMBER:	9-40-0208-B	REV:	B
ASSY NUMBER:	9-79-0208		
FILENAME:	A6FRB03A.SCH		
SCALE:			

DRAWN:	C ASMUS/JC	DATED:	7/21/00
RELEASED:	DWS	DATED:	9/19/00

ALESIS ASSEMBLY DRAWING 9-79-0208-B

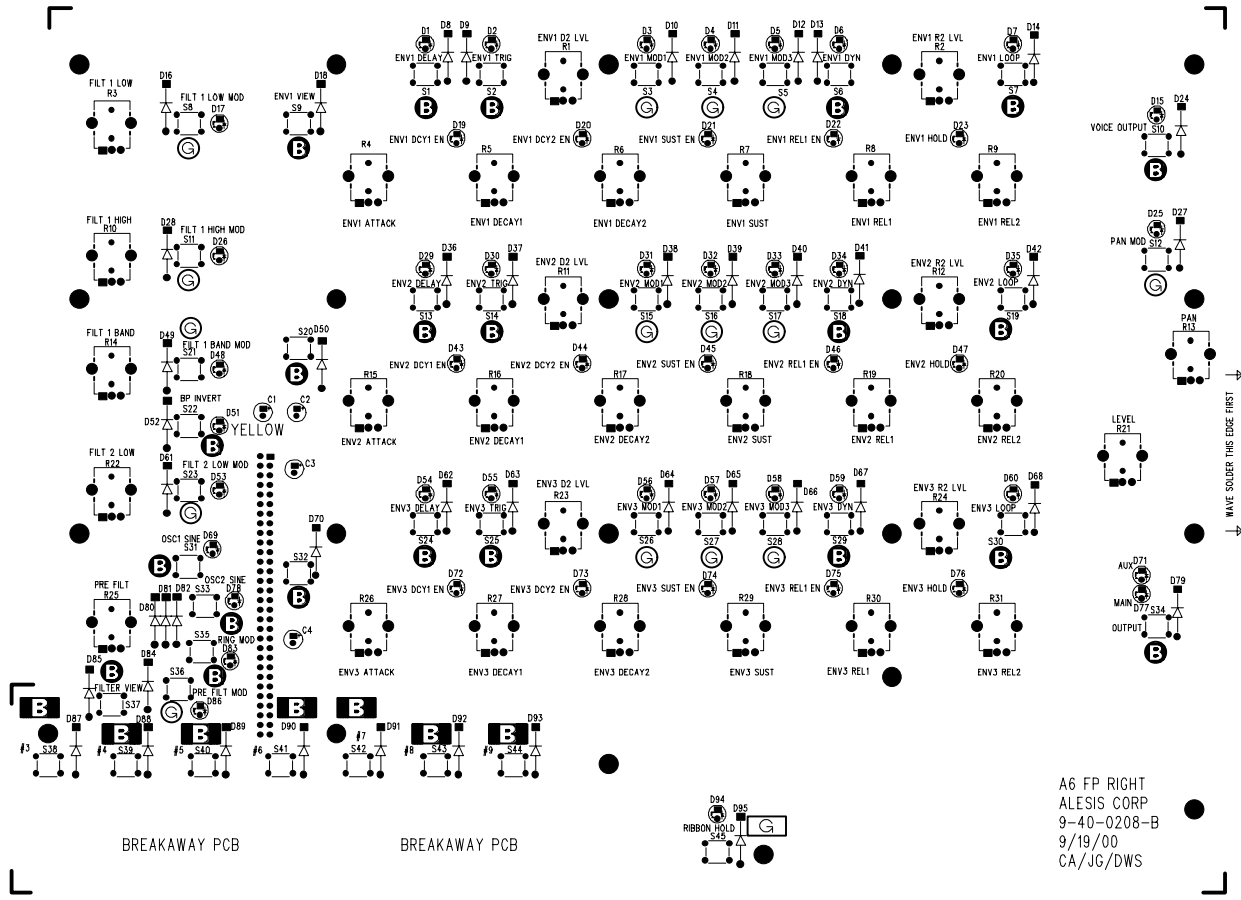

1. Hand stuff all thru-hole components (except J1) on the TOP SIDE.
2. Insert J1 (60-pin DIL header) on BOTTOM SIDE and handsolder. (Mask pads of J1 before wavesoldering surface mount components on bottom side).
3. Refer to drawings (see below) for assembling and inserting LEDs and spacers. Insert spacers with LED flush against PCB.
4. D51 is a yellow LED (3-02-0013) and is marked "YELLOW". All other LEDs are green (3-02-0021) and are unmarked.
5. Detach BREAKAWAY PCB after wave-soldering.
6. VERY IMPORTANT: ALL POTS (0-09-1096) SWITCHES (6-02-0050) AND LED ASSEMBLIES (SEE BELOW) MUST BE PERFECTLY FLUSH (FLAT) AGAINST THE PCB
7. Board to be wave soldered using Alesis supplied solder fixture.
8. Wave solder all surface mount parts and thru hole leads.
9. Board designed to be wave soldered, straight edge first (refer to notes on top assembly drawing)
10. SWITCHCAP LEGEND: "B" in a circle for BLACK circular switchcaps "G" in a circle for GRAY circular switchcaps. "B" in a rectangle for BLACK rectangular switchcaps. "G" in a rectangle for GRAY rectangular switchcaps.

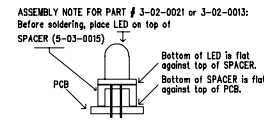
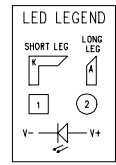

A6 FP RIGHT
 ALESIS CORP
 9-40-0208-B
 9/19/00
 CA/JG/DWS

ALESIS 9-40-0208-B "TOPSILK"

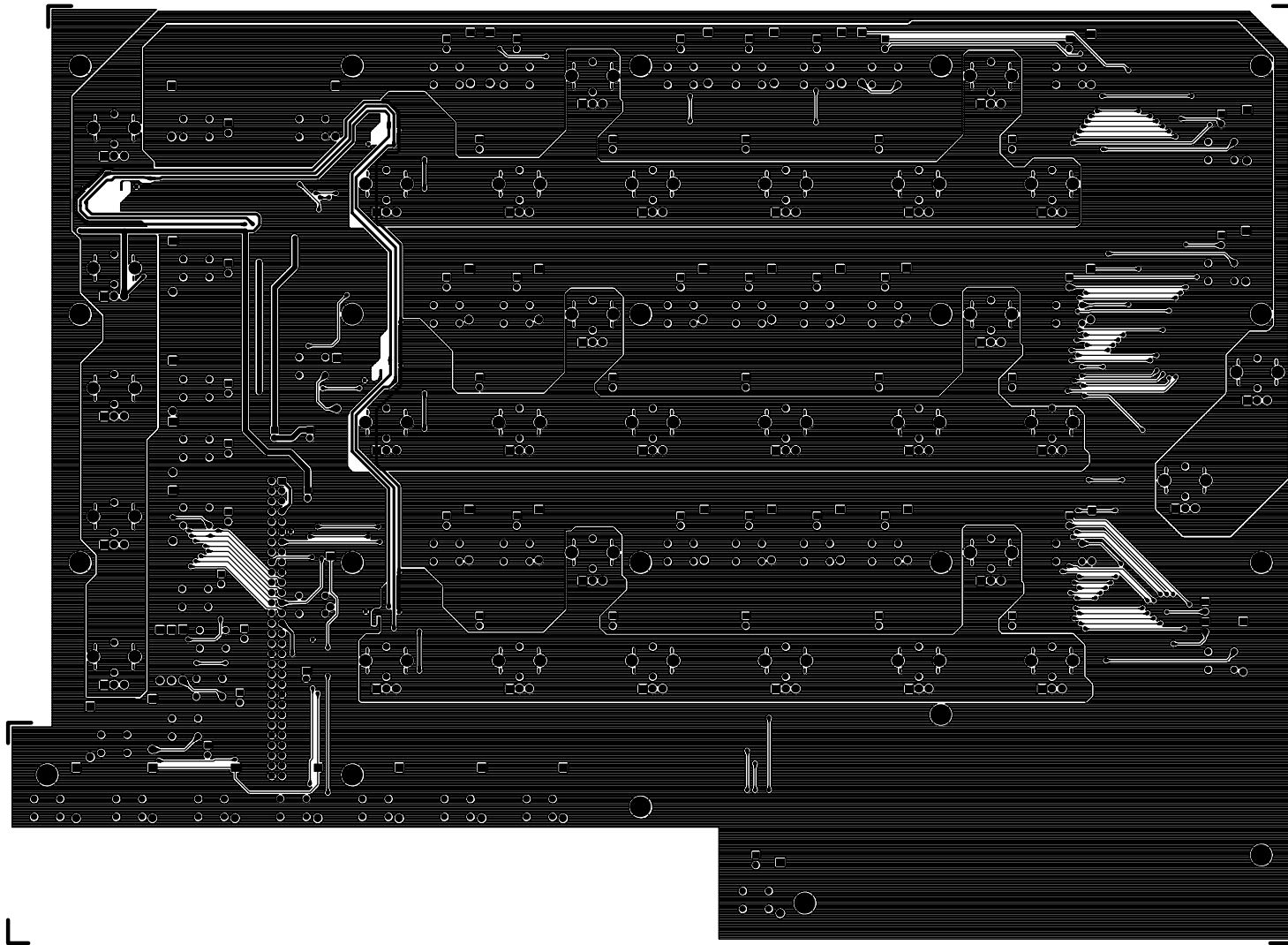

ALESIS 9-40-0208-B "TOPTRACE"



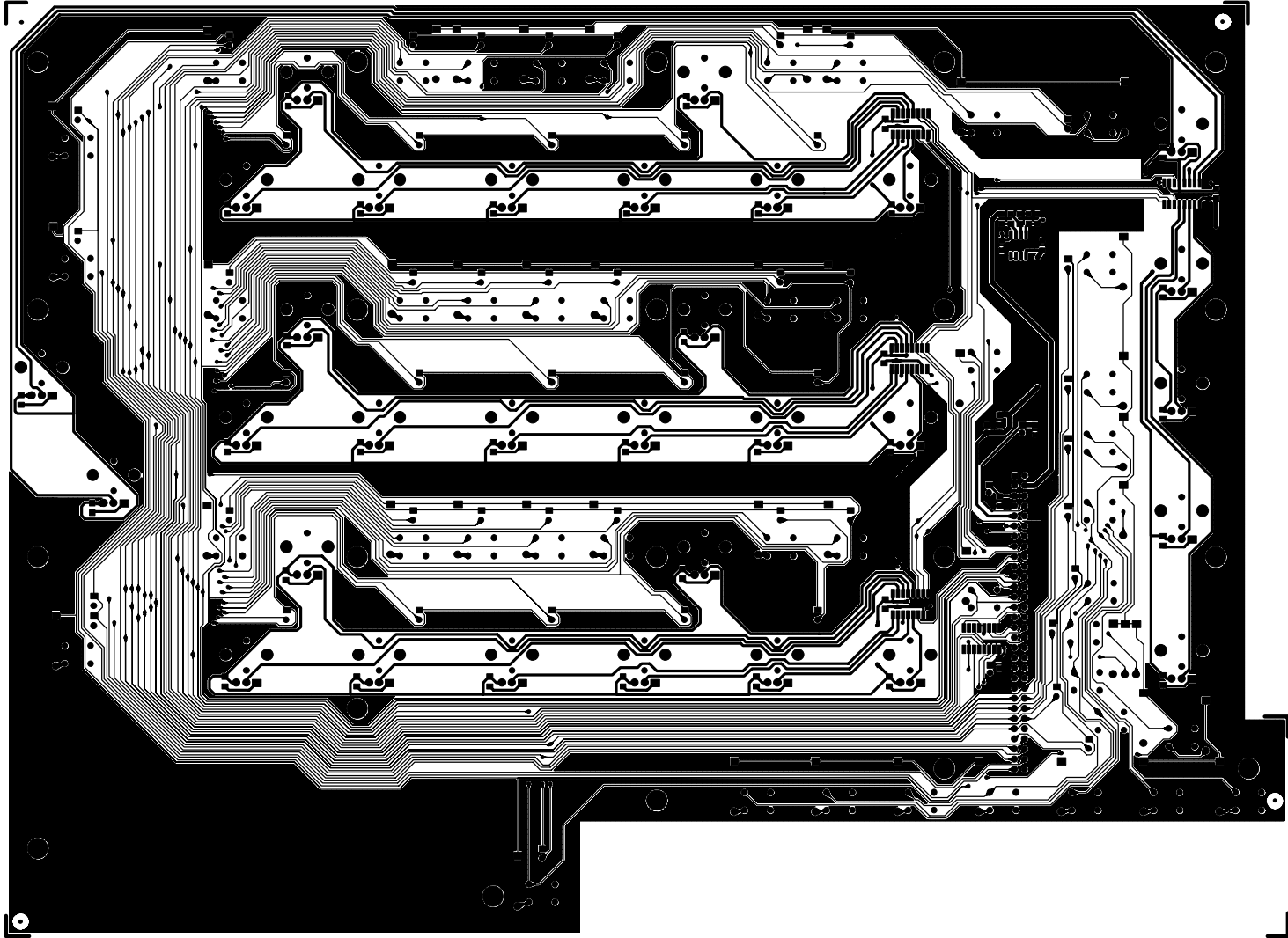

ALESIS 9-40-0208-B "BOTTRACE"

ALESIS 9-40-0208-B "BOTASSY"

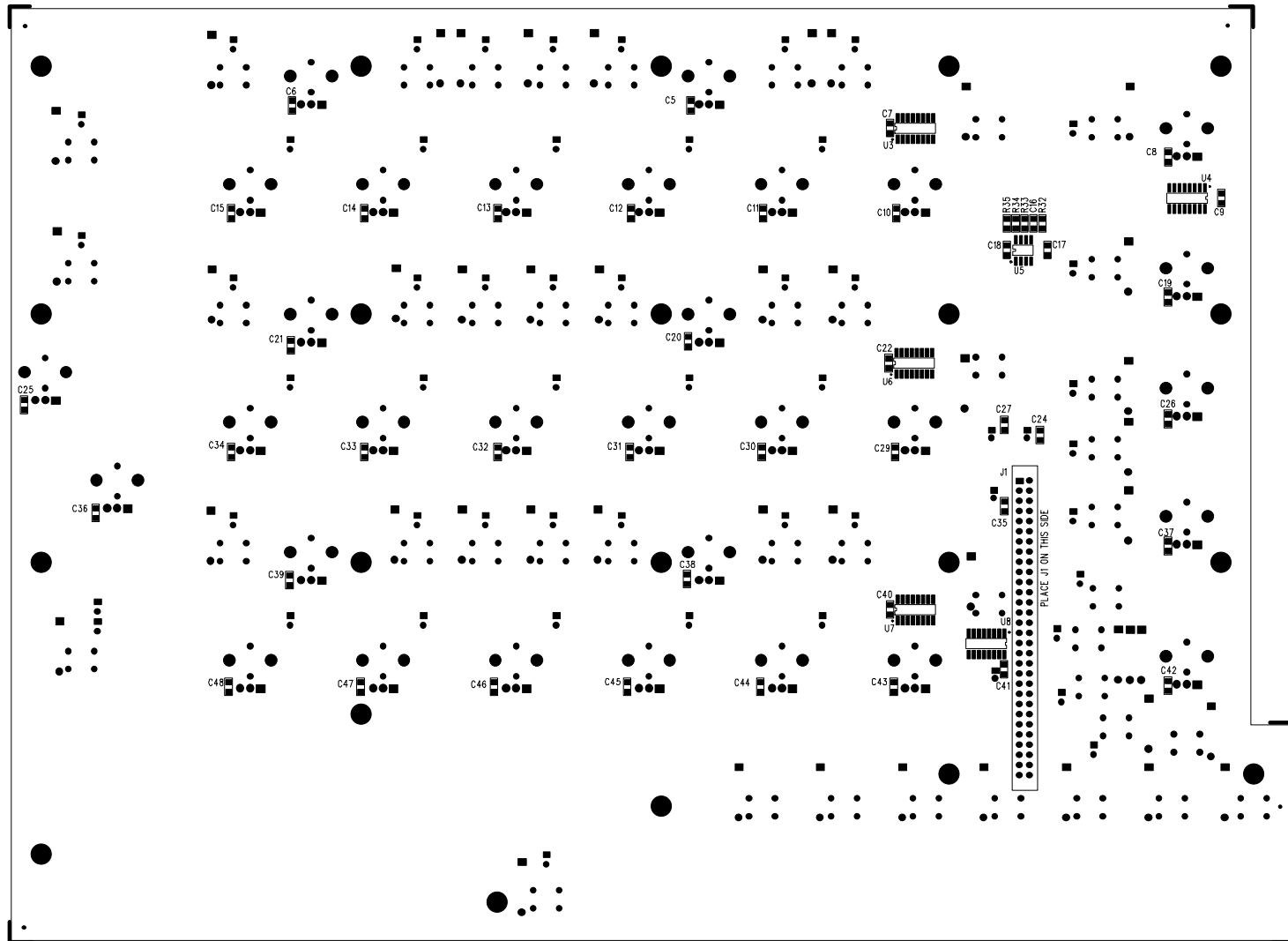

2. Insert J1 (60-pin DIL header) on **BOTTOM SIDE** and handsolder. (Mask pads of J1 before wavesoldering surface mount components on bottom side).

6

5

4

3

2

1

REVISION RECORD			
LTR	ECC NO:	APPROVED:	DATE:

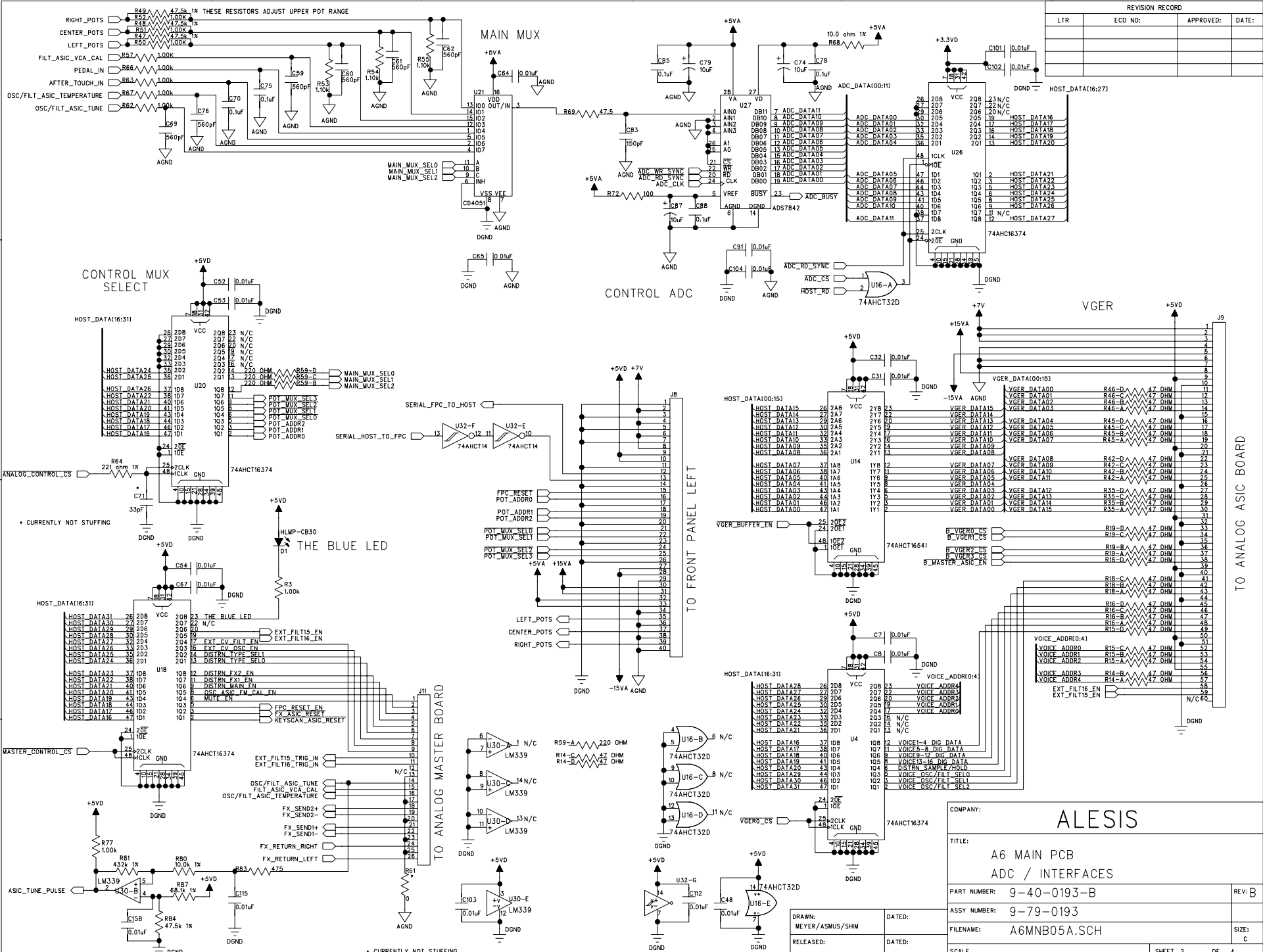

BUFFERS

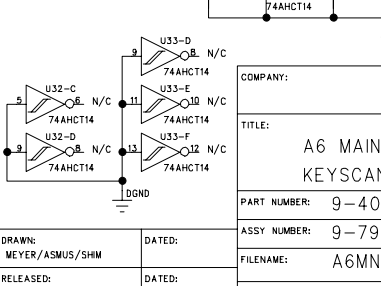
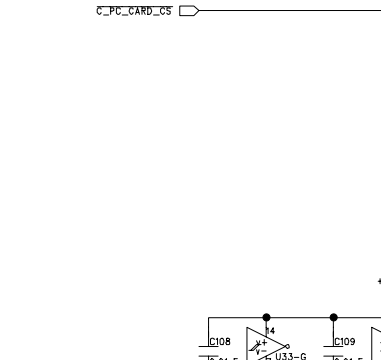
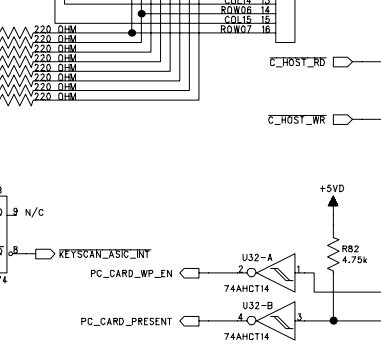
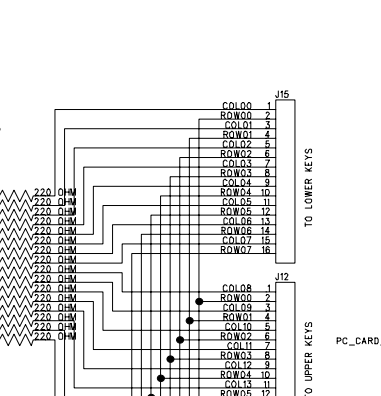
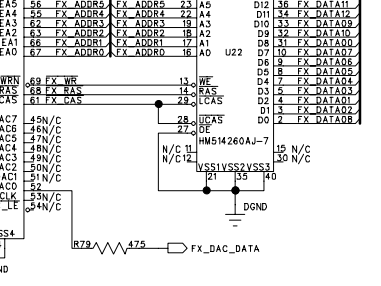
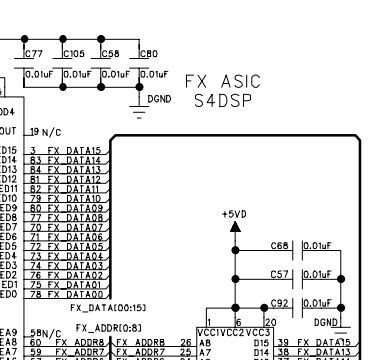
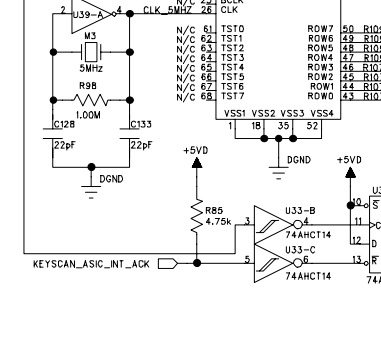
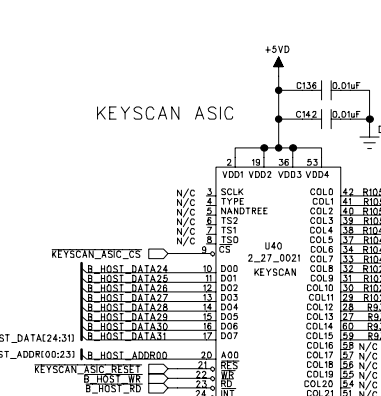
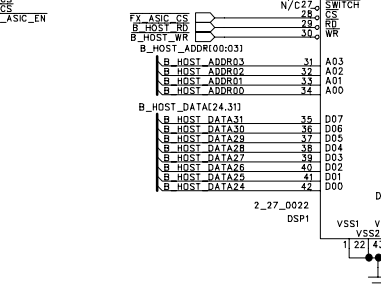
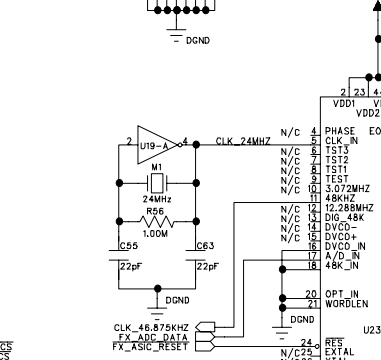
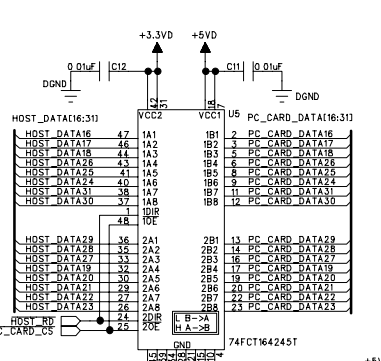
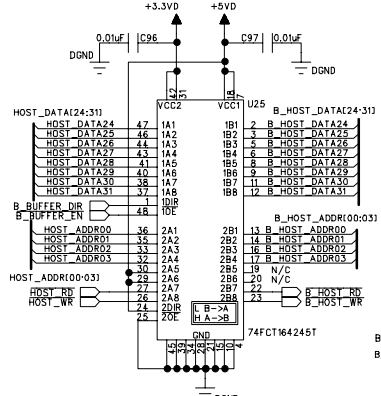
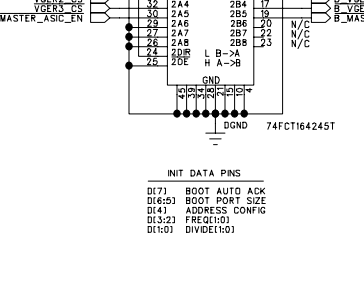
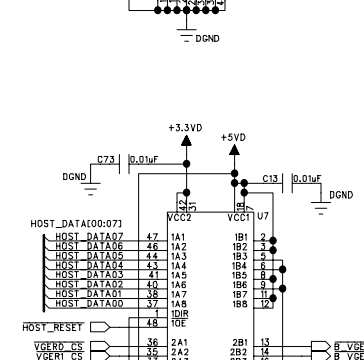
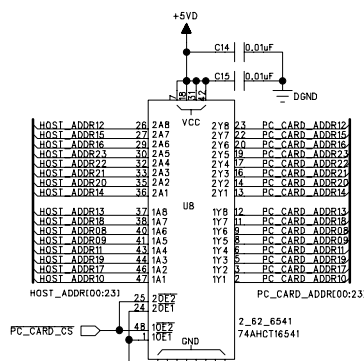
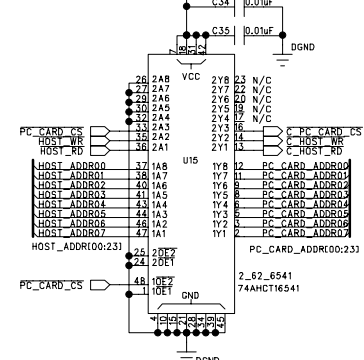

REVISION RECORD			
LTR	ECCO NO:	APPROVED:	DATE:

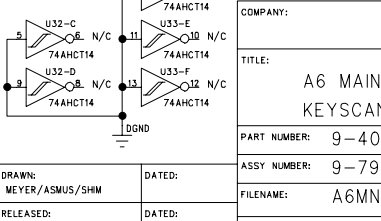
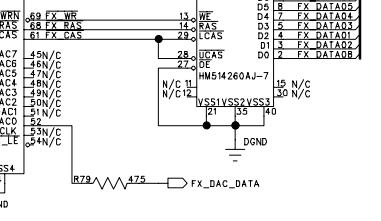
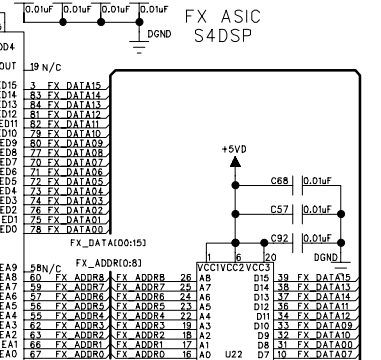
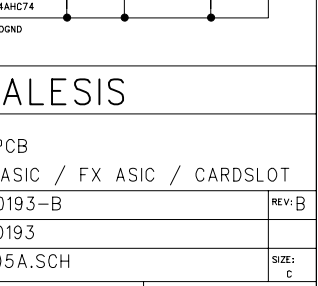
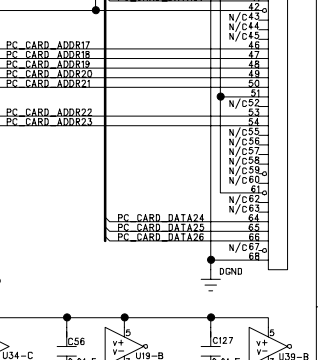
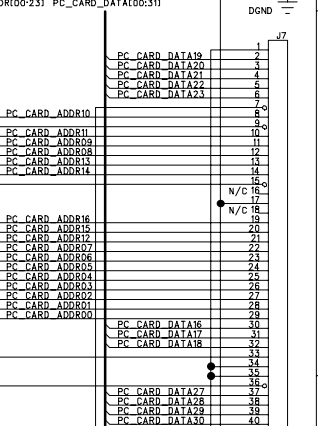
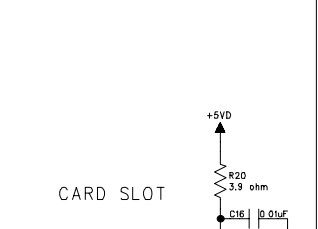

ALESIS

A6 MAIN PCB
KEYSCAN ASIC / FX ASIC / CARDSLOT

COMPANY: _____

TITLE: _____

PART NUMBER: 9-40-0193-B REV: B

ASSY NUMBER: 9-79-0193

FILENAME: A6MNB05A.SCH SIZE: C

DRAWN: MEYER/ASMUS/SHM DATED: _____

RELEASED: _____ DATED: _____

SCALE: _____ SHEET: 3 OF 4

6

5

4

3

2

1

REVISION RECORD			
LTR	ECD NO:	APPROVED:	DATE:

FULL SCALE INPUT
+/- 4.0V P-P ON EACH PIN/ 5.23dBu

FULL SCALE OUTPUT
+/- 4.0V ON EACH PIN
(8.0V P-P / 11.25dBu)

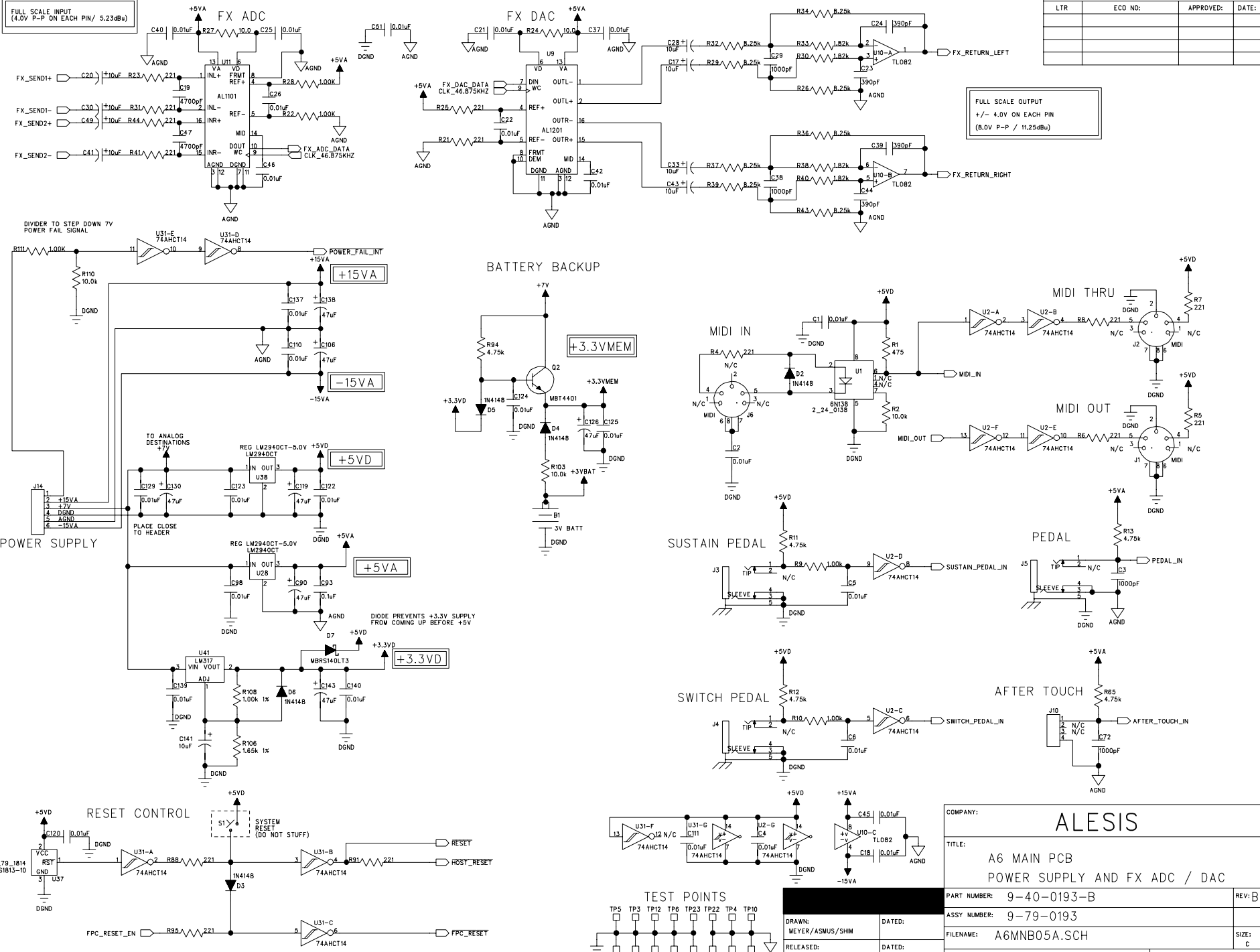

COMPANY:	ALESIS		
TITLE:	A6 MAIN PCB POWER SUPPLY AND FX ADC / DAC		
PART NUMBER:	9-40-0193-B	REV:	B
ASSY NUMBER:	9-79-0193		
FILENAME:	A6MNB05A.SCH		
SCALE:		SHEET: 4	OF 4

D

C

B

A

D

C

B

A

ALESIS 9-40-0193-B A6 MAIN PCB ASSEMBLY DRAWING

1. Trim all leads to extend less than 100 mils (2.5mm)
2. Do not stuff any caps on the bottom side (144-157 (1-56-0102)
3. Do not stuff the following: R61 (0-15-0000); S1 (6-02-0050); C71 (1-55-0339)
4. Assemble D1 LED (3-02-0026) and LED holder (5-03-0029), by completely inserting the LED through the oval, and then bending the legs of the LED perpendicular into the two slots, (see drawing)
5. TP15-19 (top PORT) could be substituted with an 8-pin 0.1" unshrouded SIL header with pin 5 removed. Can also substitute a 3-pin (4-15-00003) and a 4-pin (4-15-0004) 0.1" unshrouded SIL header.
6. Please refer to drawing (see below) for the regulator assemblies (U28, U38, U41).

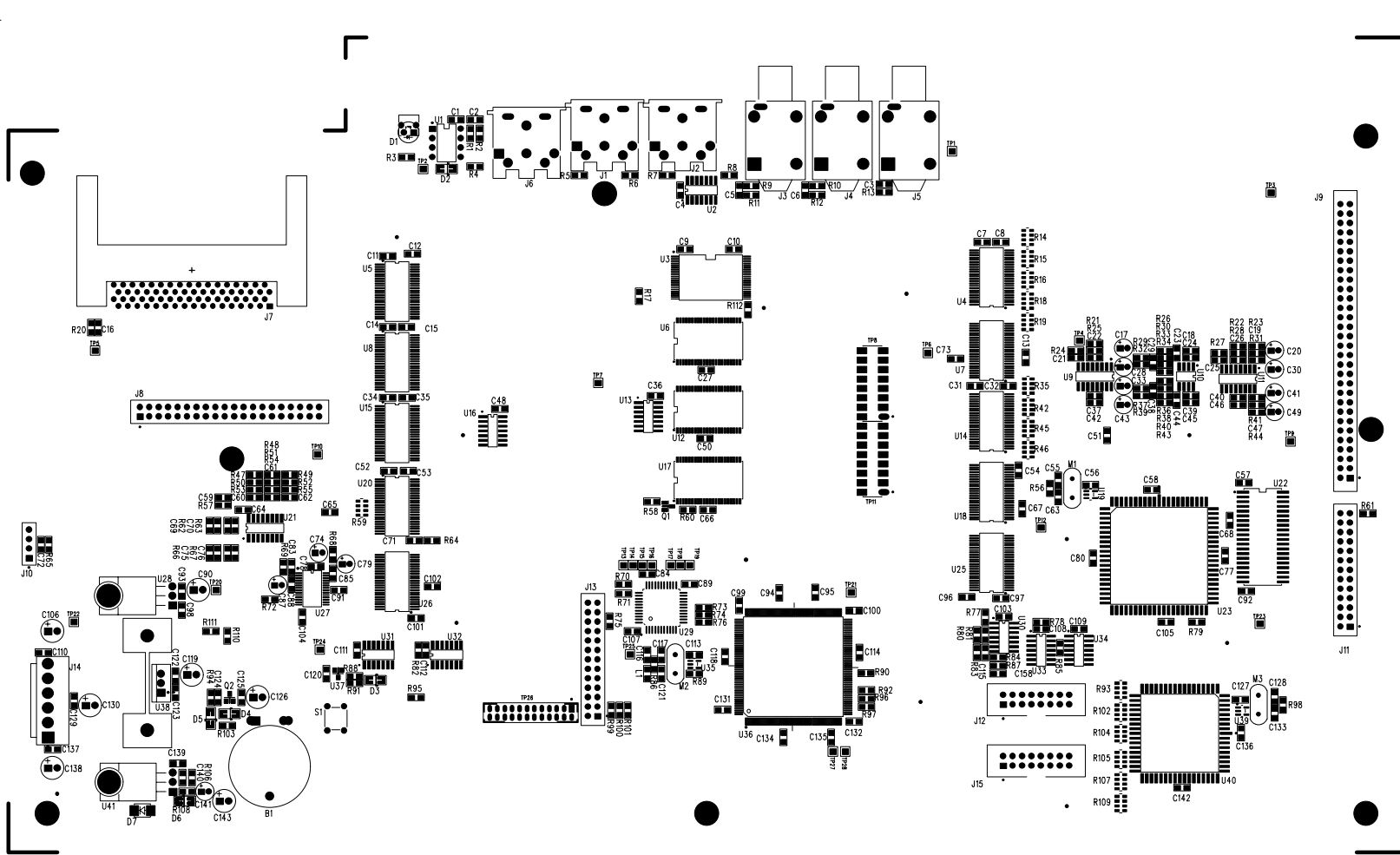
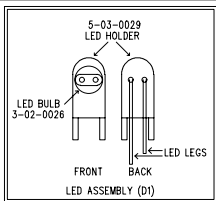
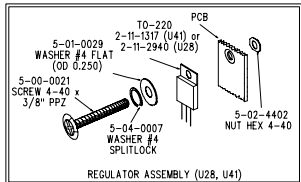
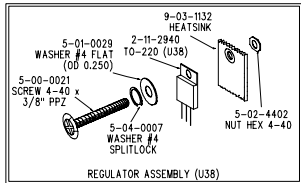

ALESIS 9-40-0193-B "TOPASSY"

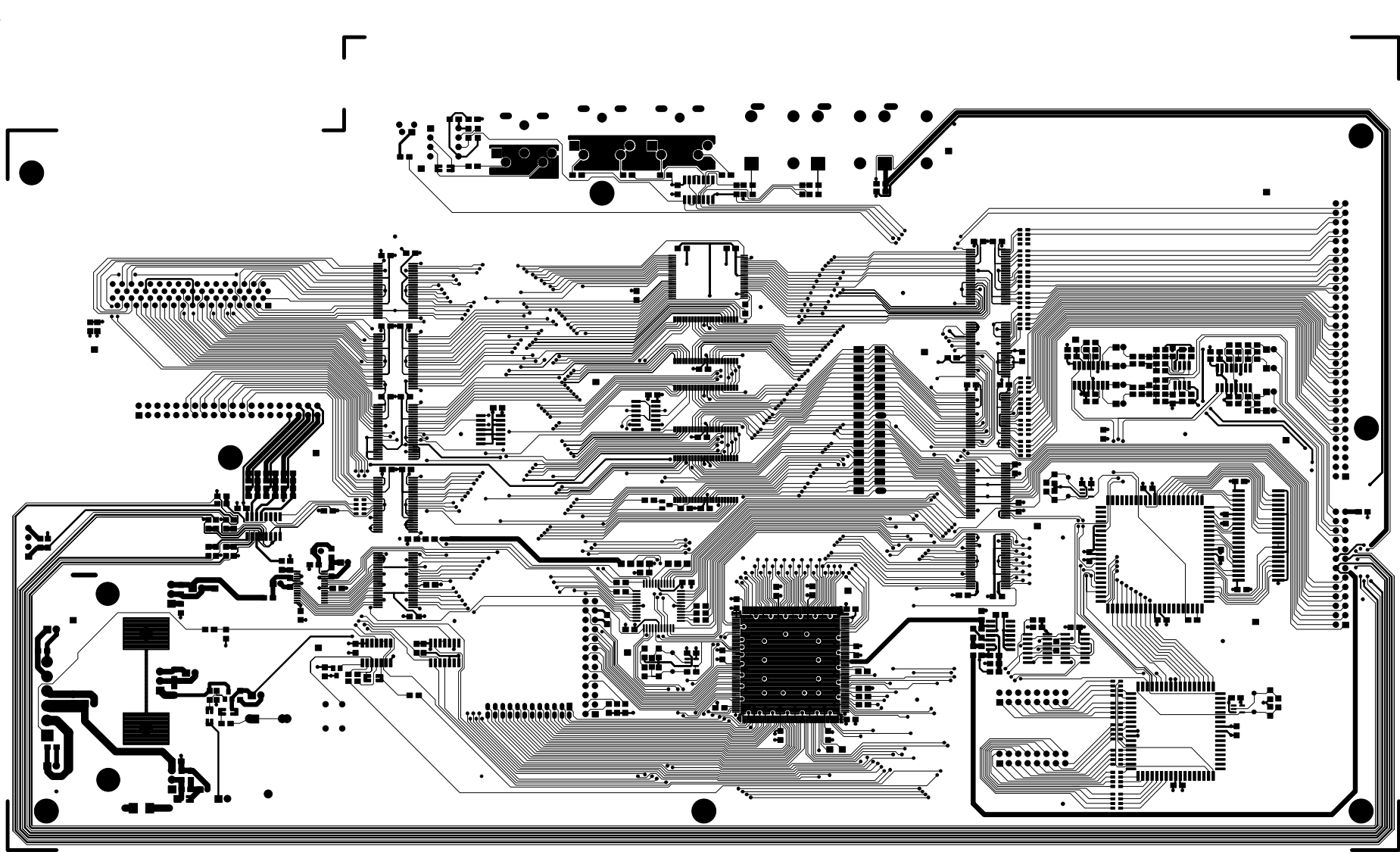

ALESIS 9-40-0193-B "TOPTRACE"

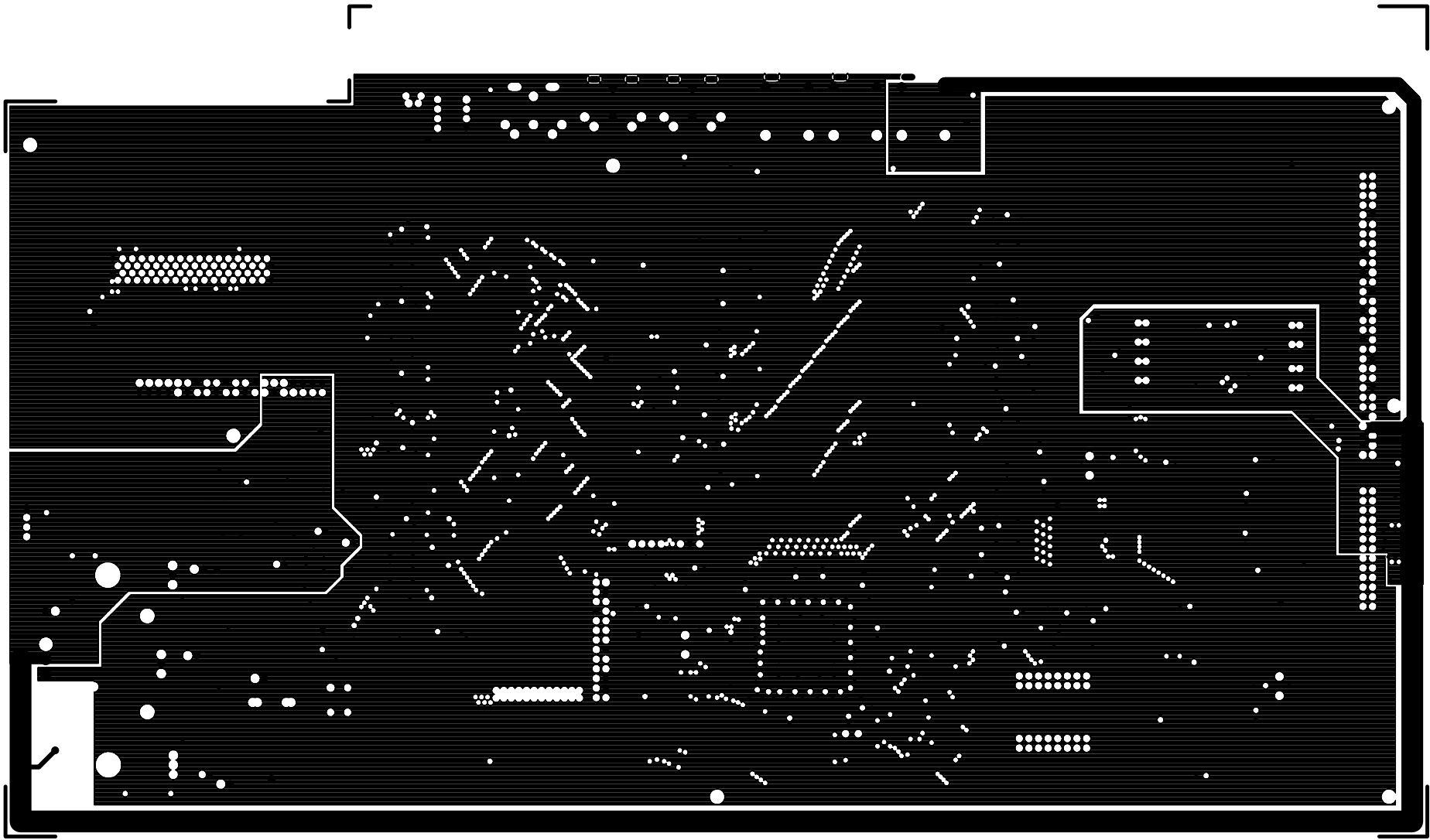

ALESIS 9-40-0193-B "GNDPLANE: LAYER 2"



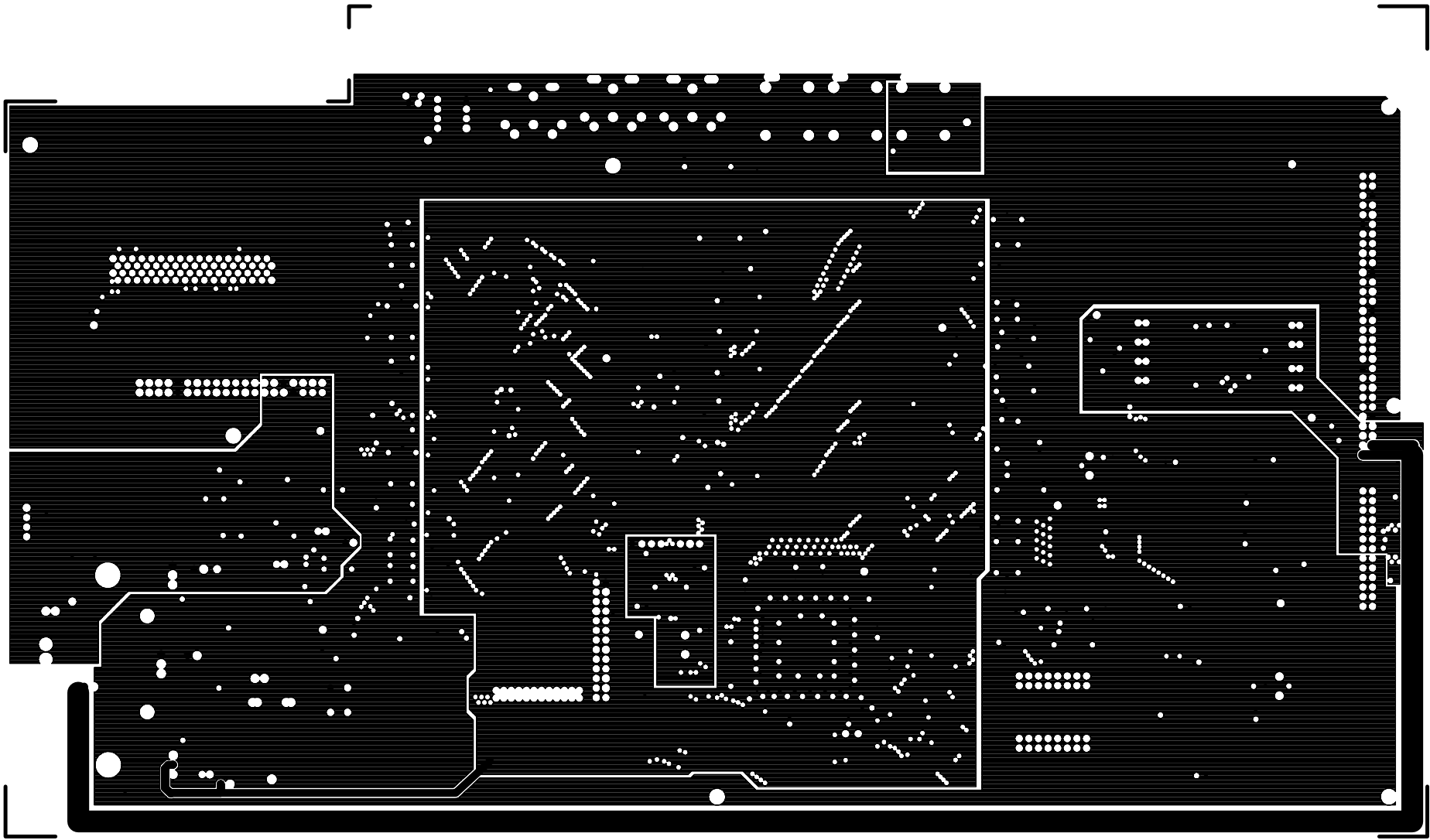

ALESIS 9-40-0193-B "PWRPLANE: LAYER 3"



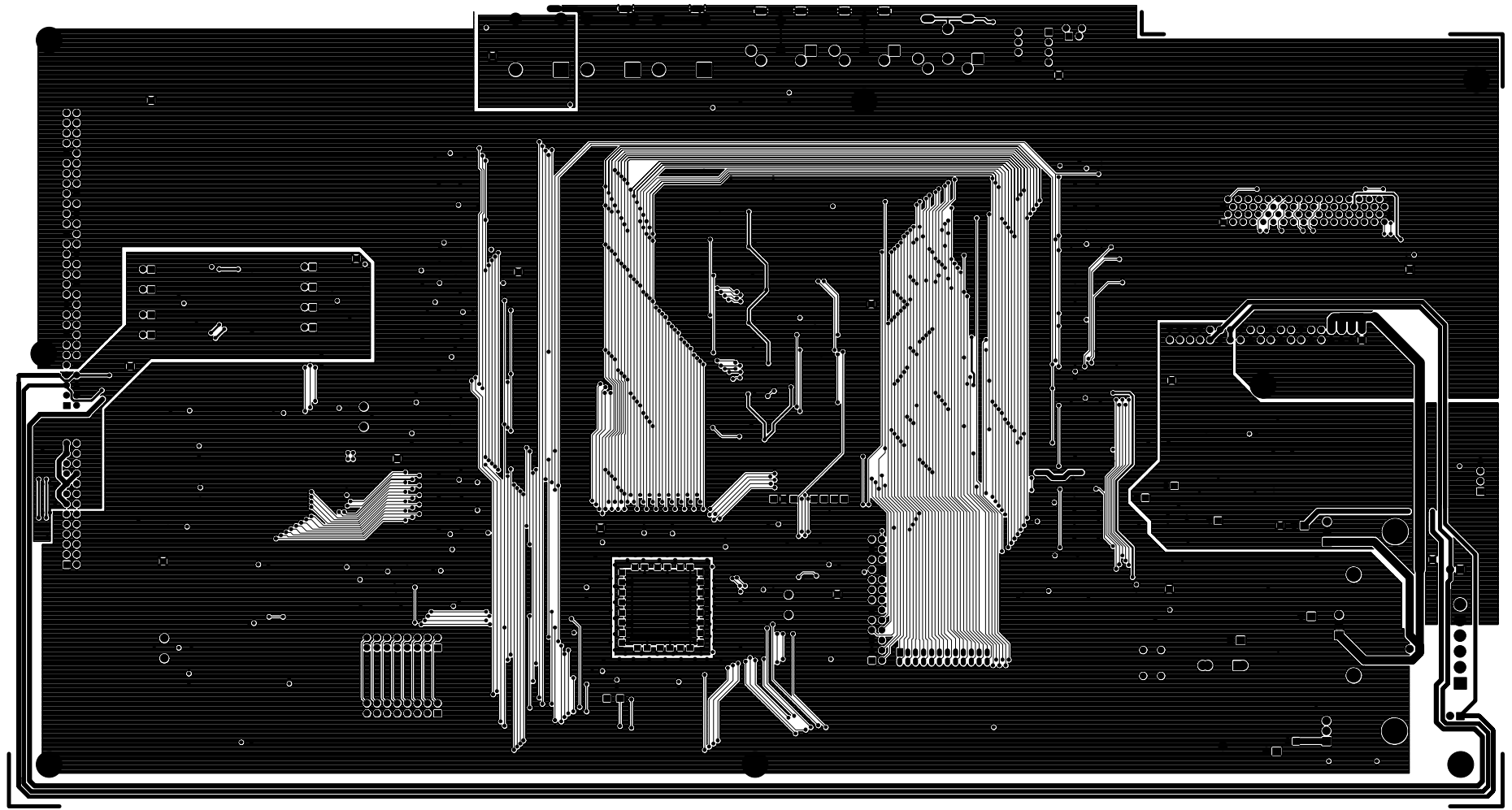

ALESIS 9-40-0193-B "BOTTRACE"

REVISION RECORD			
LTR	ECC NO:	APPROVED:	DATE:

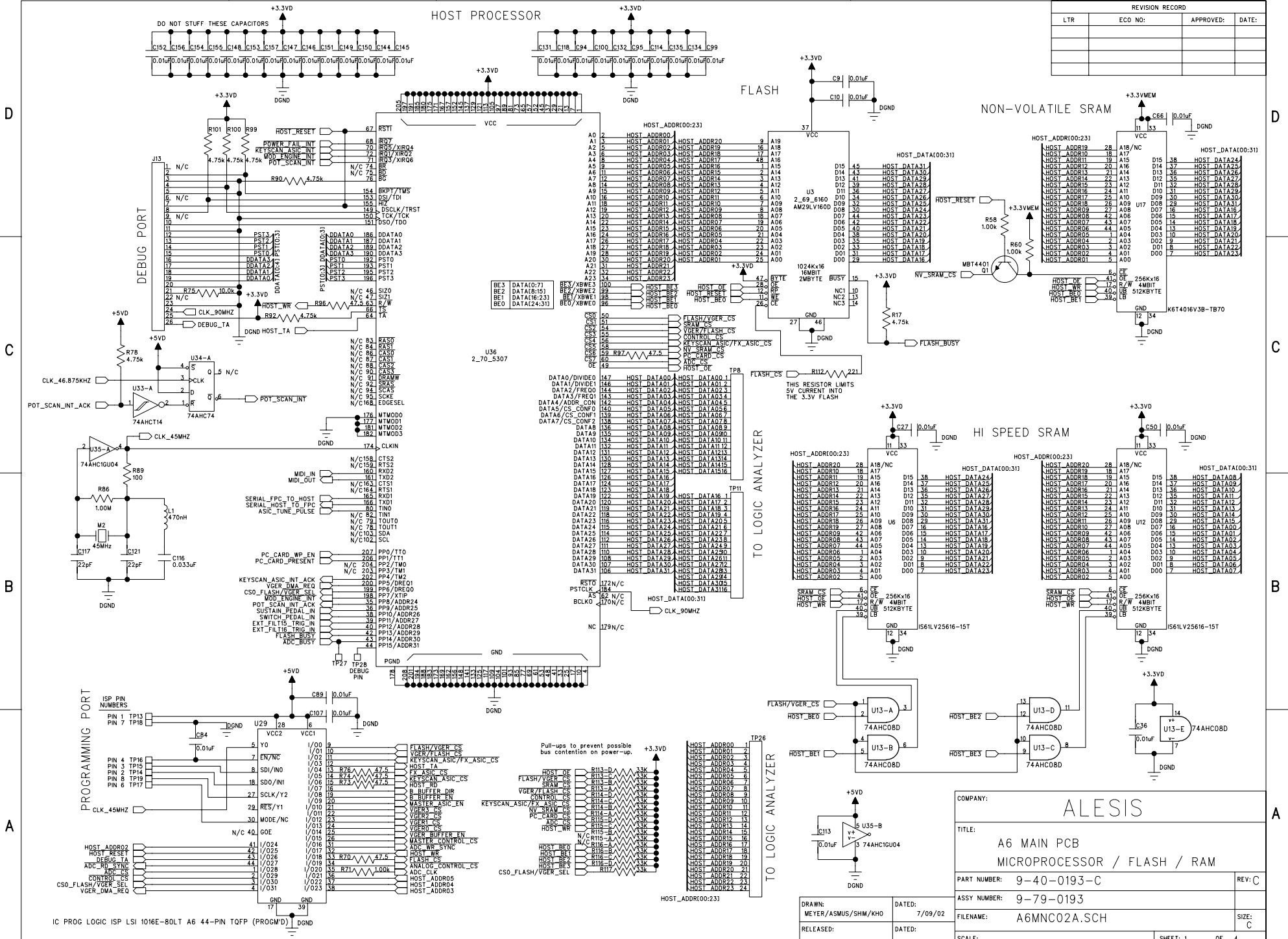

COMPANY: ALESIS

TITLE: A6 MAIN PCB MICROPROCESSOR / FLASH / RAM

PART NUMBER: 9-40-0193-C

REV: C

ASSY NUMBER: 9-79-0193

FILENAME: A6MNC02A.SCH

SCALE: SHEET: 1 OF 4

DRAWN: MEYER/ASMUS/SHH/KHO

DATED: 7/09/02

RELEASED:

DATED:

IC PROG LOGIC ISP LSI 1016E-80LT A6 44-PIN TOFP (PROGM'D)

REVISION RECORD			
LTR	ECO NO:	APPROVED:	DATE:

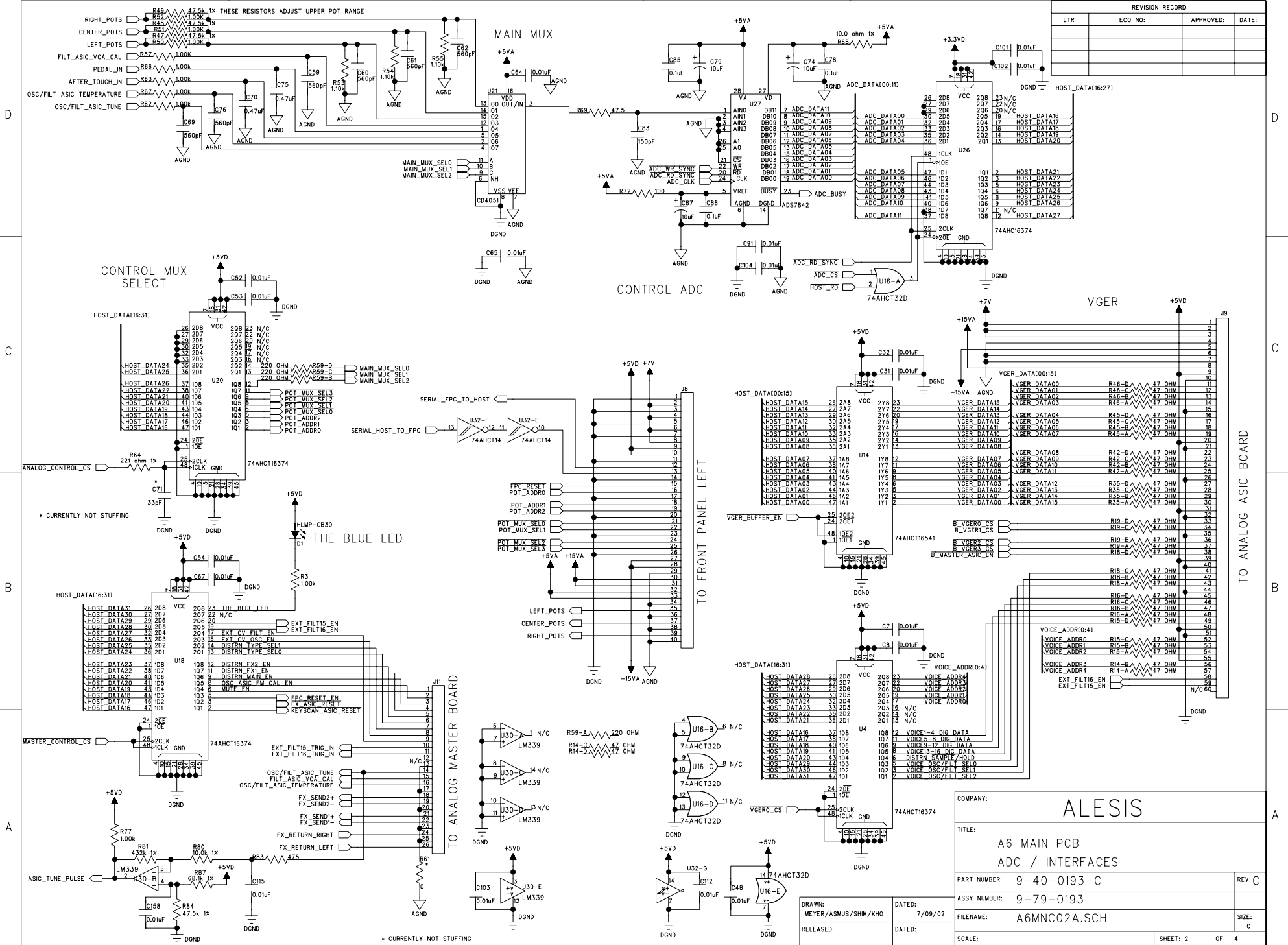

COMPANY: ALESIS

TITLE: A6 MAIN PCB
ADC / INTERFACES

PART NUMBER: 9-40-0193-C

ASSY NUMBER: 9-79-0193

FILENAME: A6MNC02A.SCH

SCALE: SHEET: 2 OF 4

DRAWN: MEYER/ASMUS/SHH/KHO

DATED: 7/09/02

RELEASED: DATED:

REV: C

SIZE: C

BUFFERS

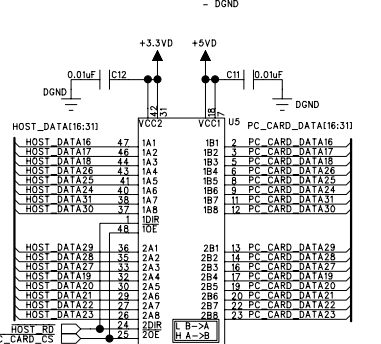
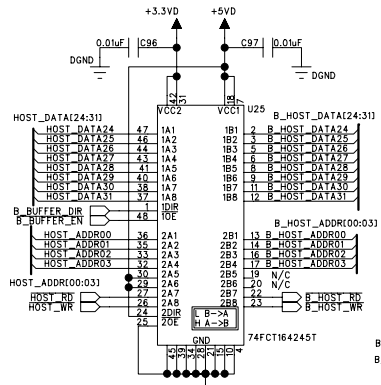
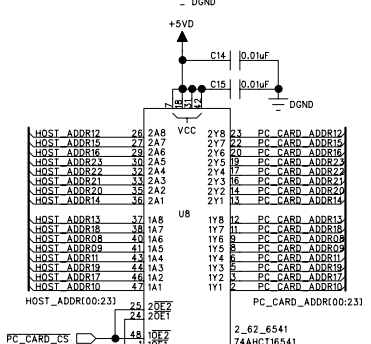
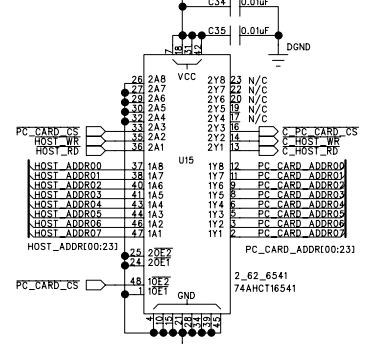

KEYSCAN ASIC

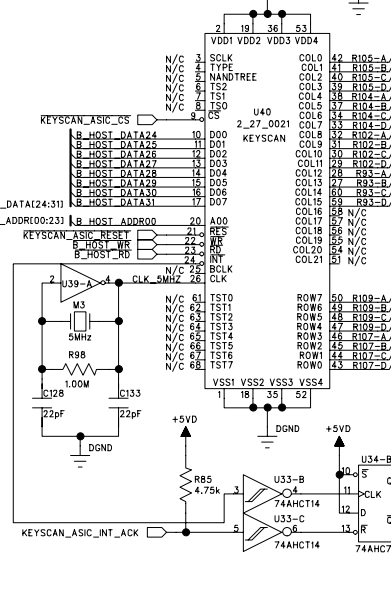

FX ASIC S4DSP

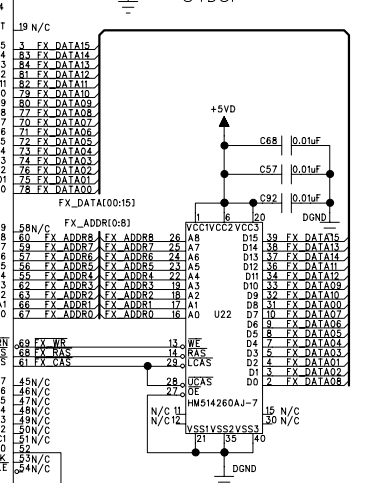

REVISION RECORD			
LTR	ECO NO:	APPROVED:	DATE:

CARD SLOT

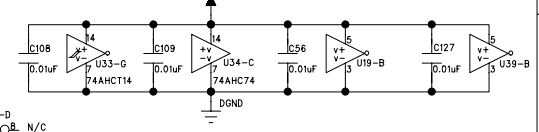
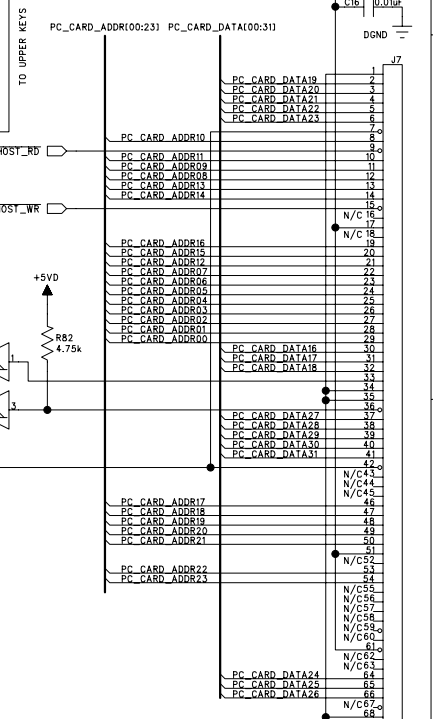

INIT DATA PINS
 D[7] BOOT AUTO ACK
 D[6:5] BOOT PORT SIZE
 D[4:2] ADDRESS CONFIG
 D[1:0] DIVIDE[10]

COMPANY:
ALESIS

TITLE:
 A6 MAIN PCB
 KEYSKAN ASIC / FX ASIC / CARDSLOT

PART NUMBER: 9-40-0193-C **REV:** C

ASSY NUMBER: 9-79-0193

FILENAME: A6MNC02A.SCH **SIZE:** C

DRAWN: MEYER/ASMUS/SHM/KHO **DATED:** 7/09/02

RELEASED: **DATED:** **SCALE:** **SHEET:** 3 OF 4

6

5

4

3

2

1

REVISION RECORD			
LTR	ECO NO:	APPROVED:	DATE:

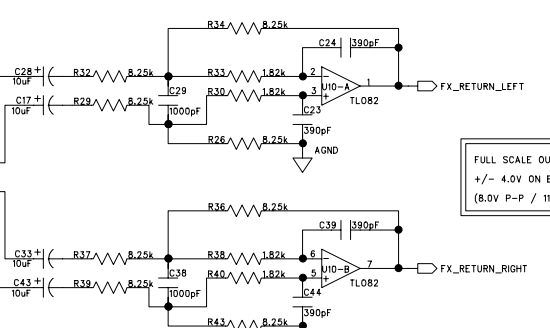
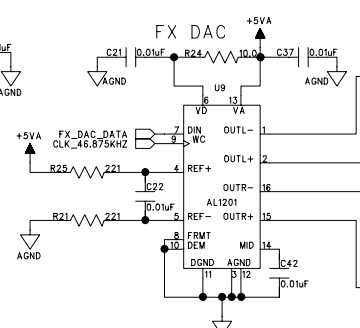
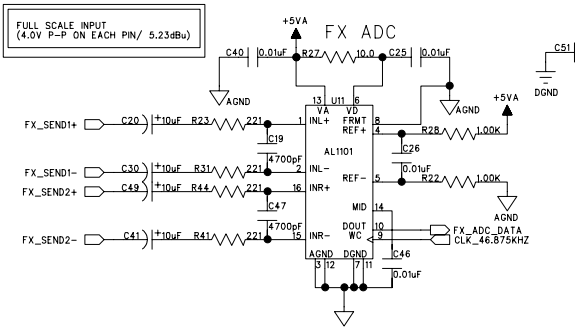

FULL SCALE OUTPUT
+/- 4.0V ON EACH PIN
(8.0V P-P / 11.25dBu)

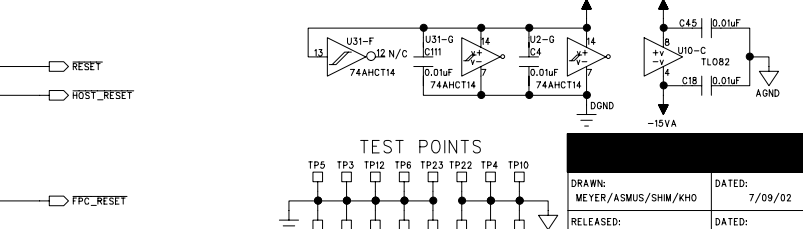
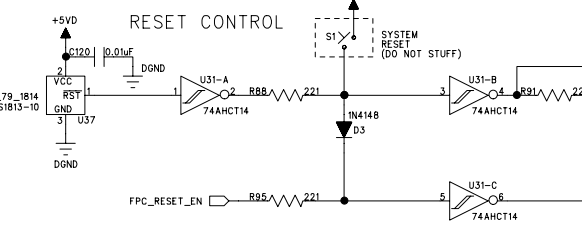
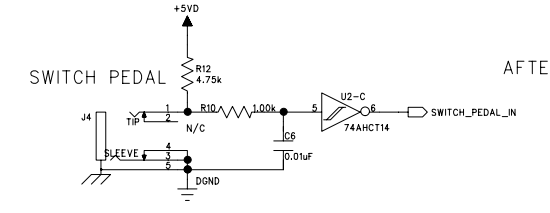
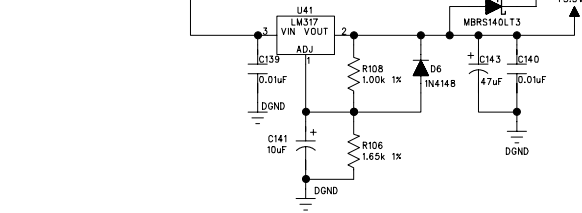
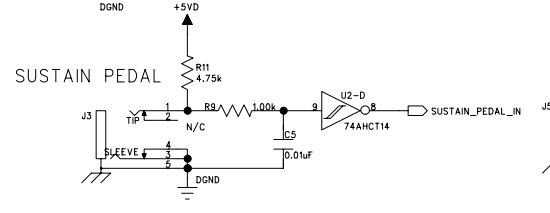
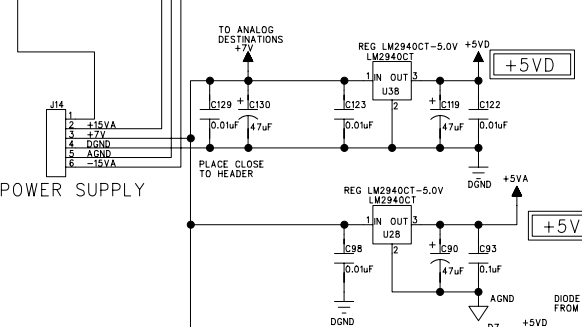
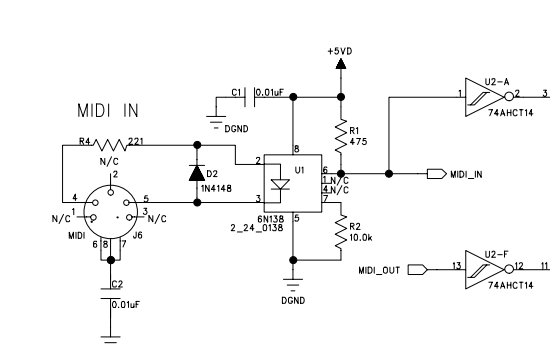
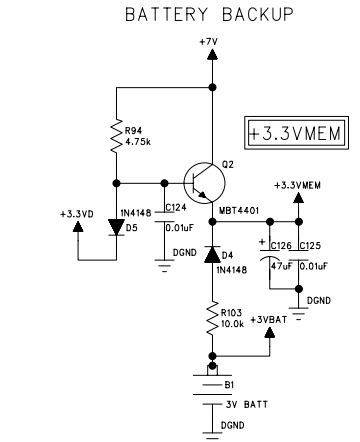
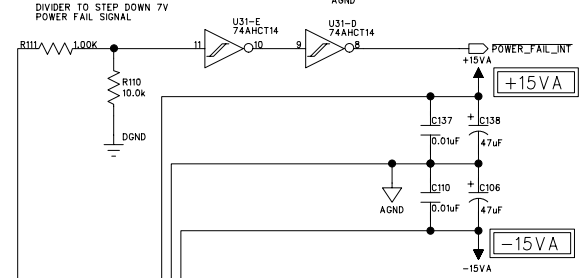

COMPANY:	ALESIS		
TITLE:	A6 MAIN PCB POWER SUPPLY AND FX ADC / DAC		
PART NUMBER:	9-40-0193-C	REV:	C
ASSY NUMBER:	9-79-0193	FILENAME:	A6MNC02A.SCH
SCALE:	SHEET: 4 OF 4		

D

C

B

A

D

C

B

A

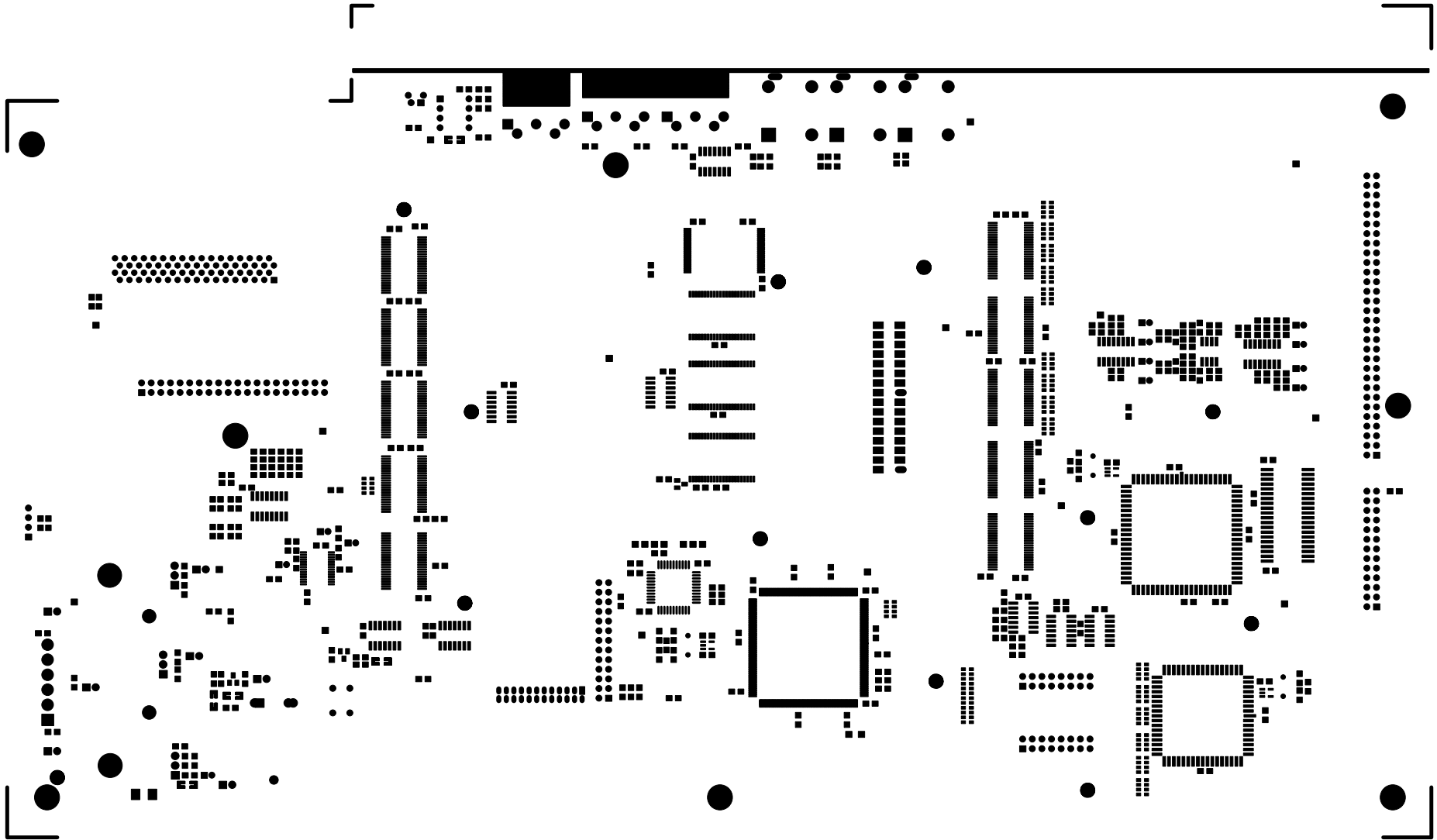

ALESIS 9-40-0193-C "TOPSMK"

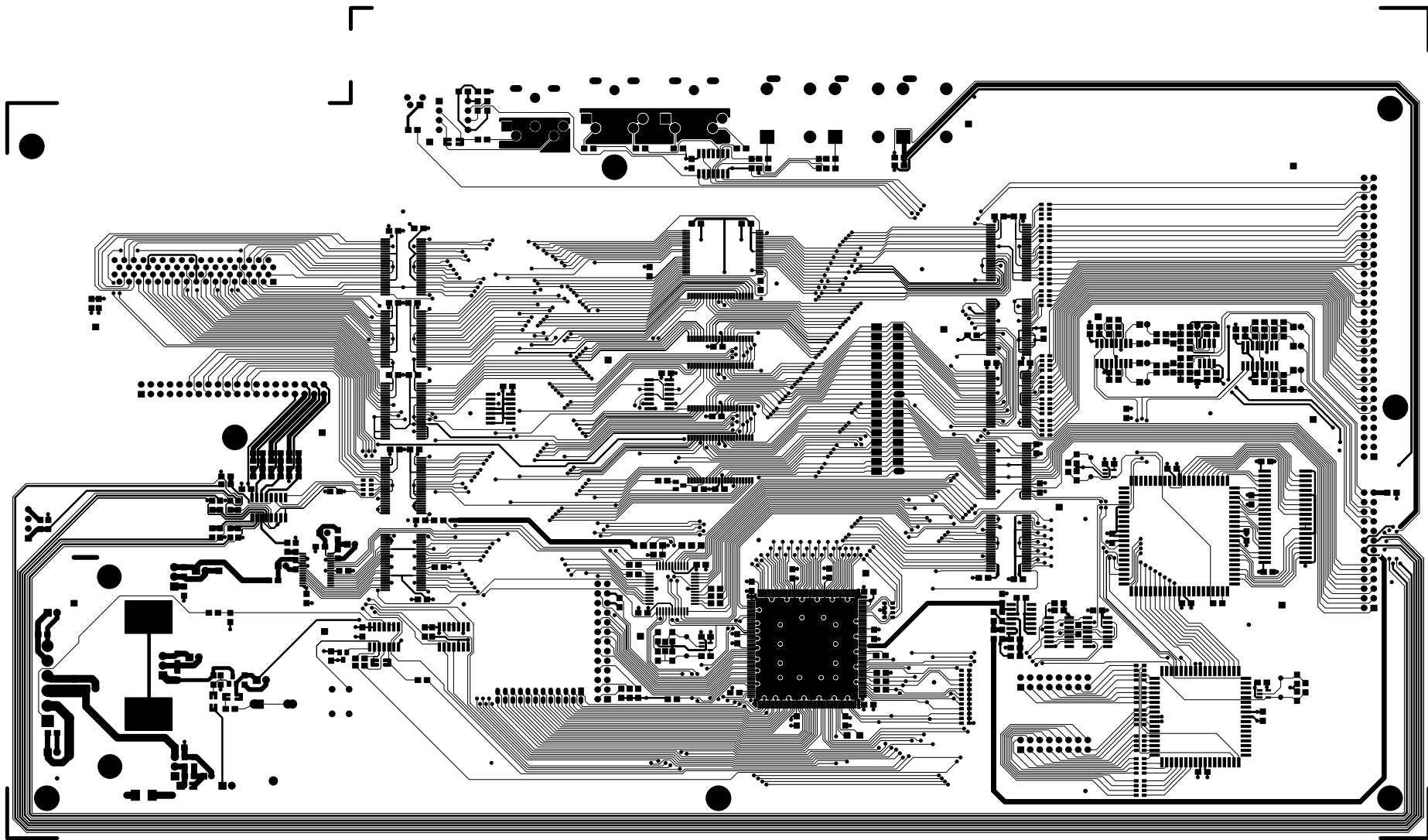

ALESIS 9-40-0193-C "TOPTRACE"

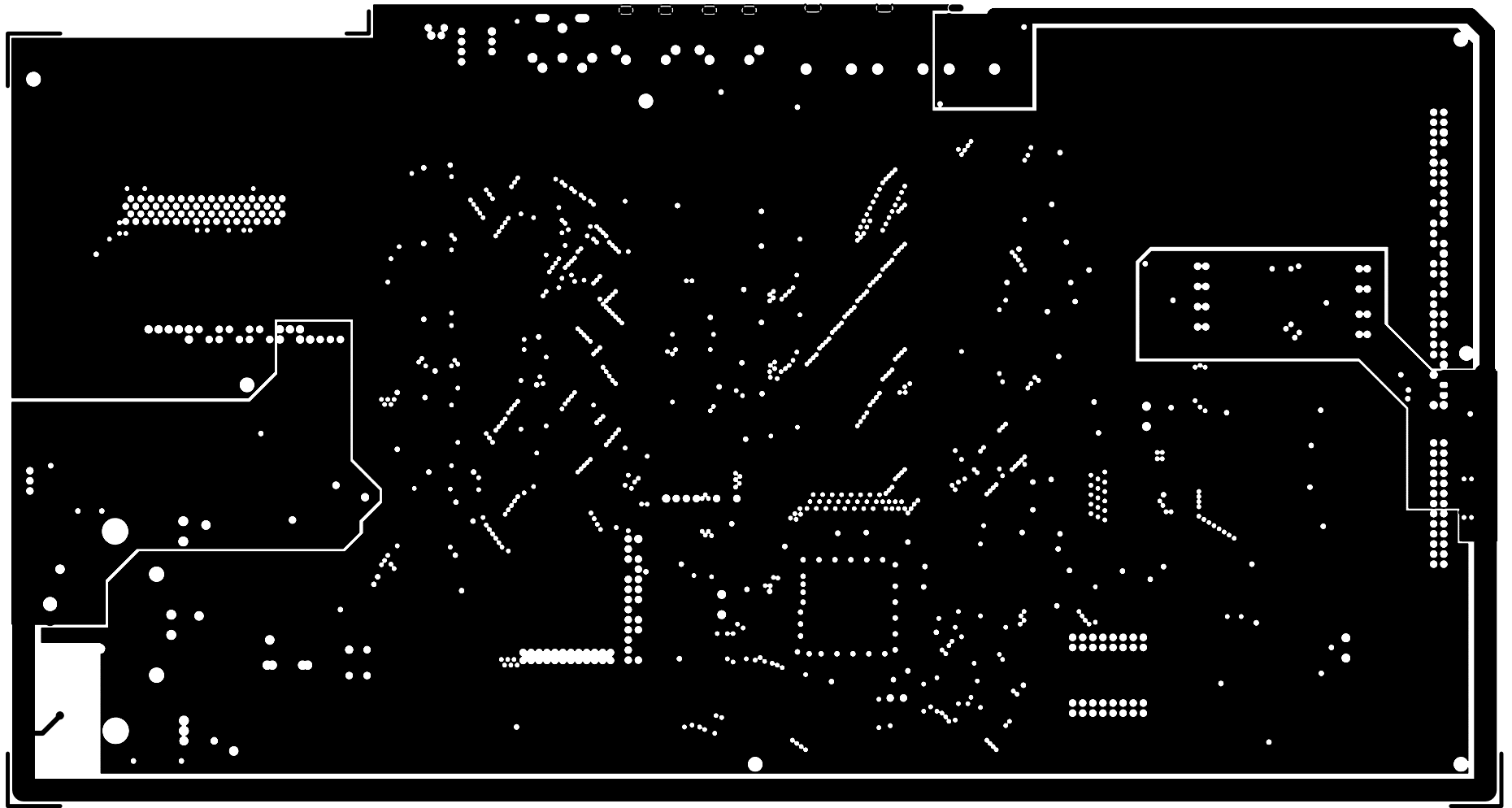

ALESIS 9-40-0193-C "GNDPLANE: LAYER 2"



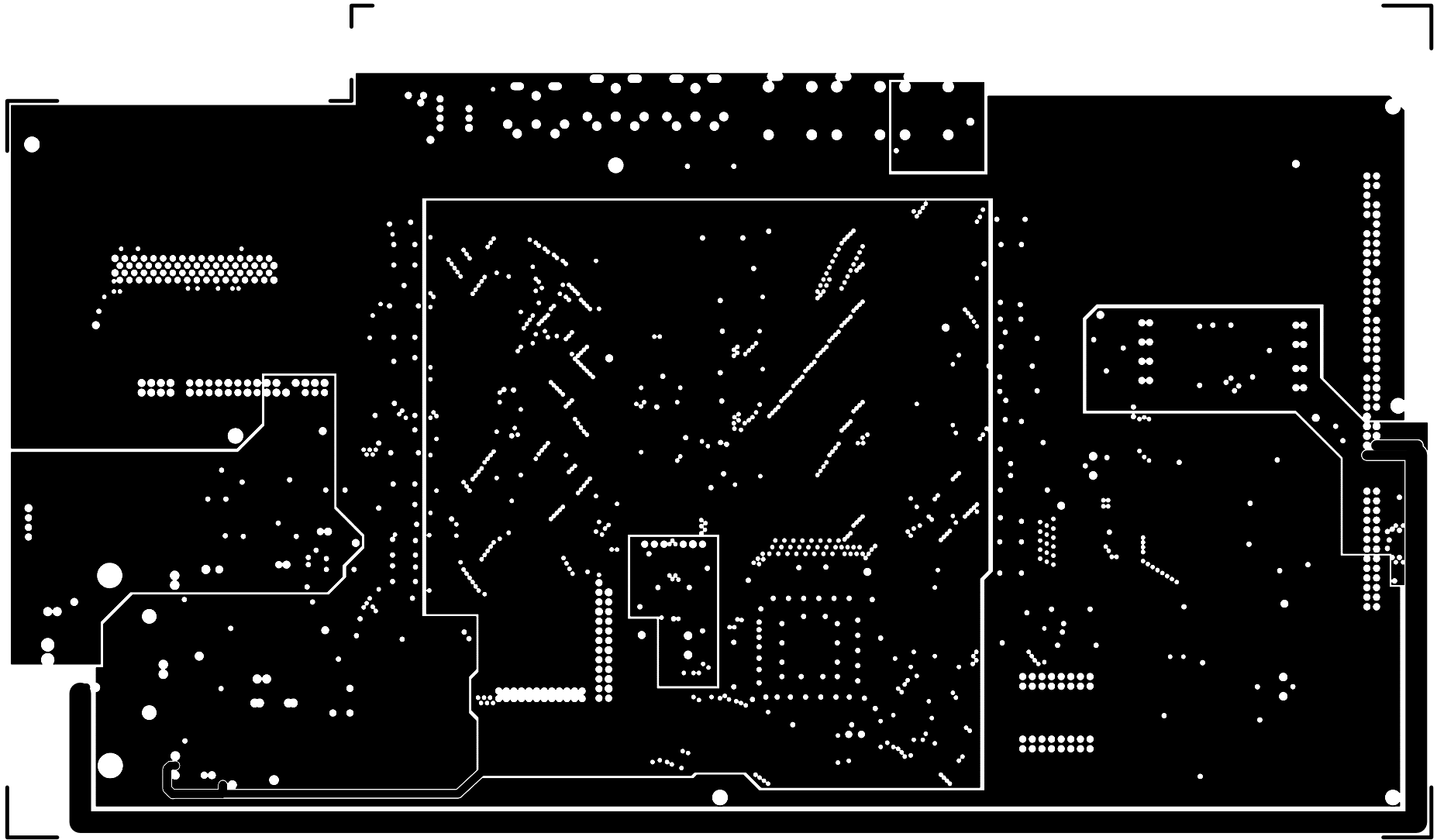

ALESIS 9-40-0193-C "PWRPLANE: LAYER 3"



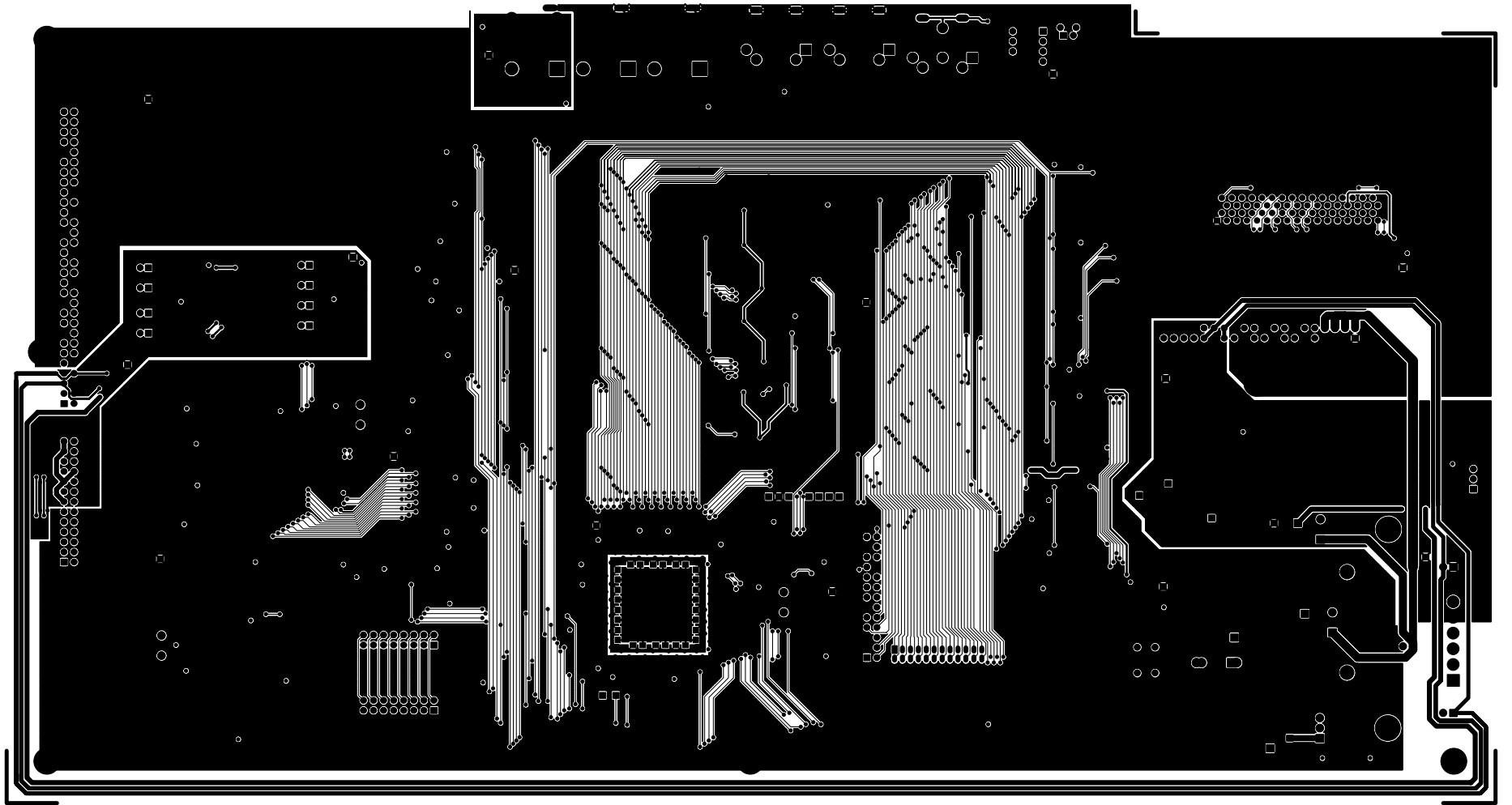

ALESIS 9-40-0193-C "BOTTRACE"



6

5

4

3

2

1

REVISION RECORD			
LTR.	ECO NO:	APPROVED:	DATE:

E

E

D

D

C

C

B

B

A

A

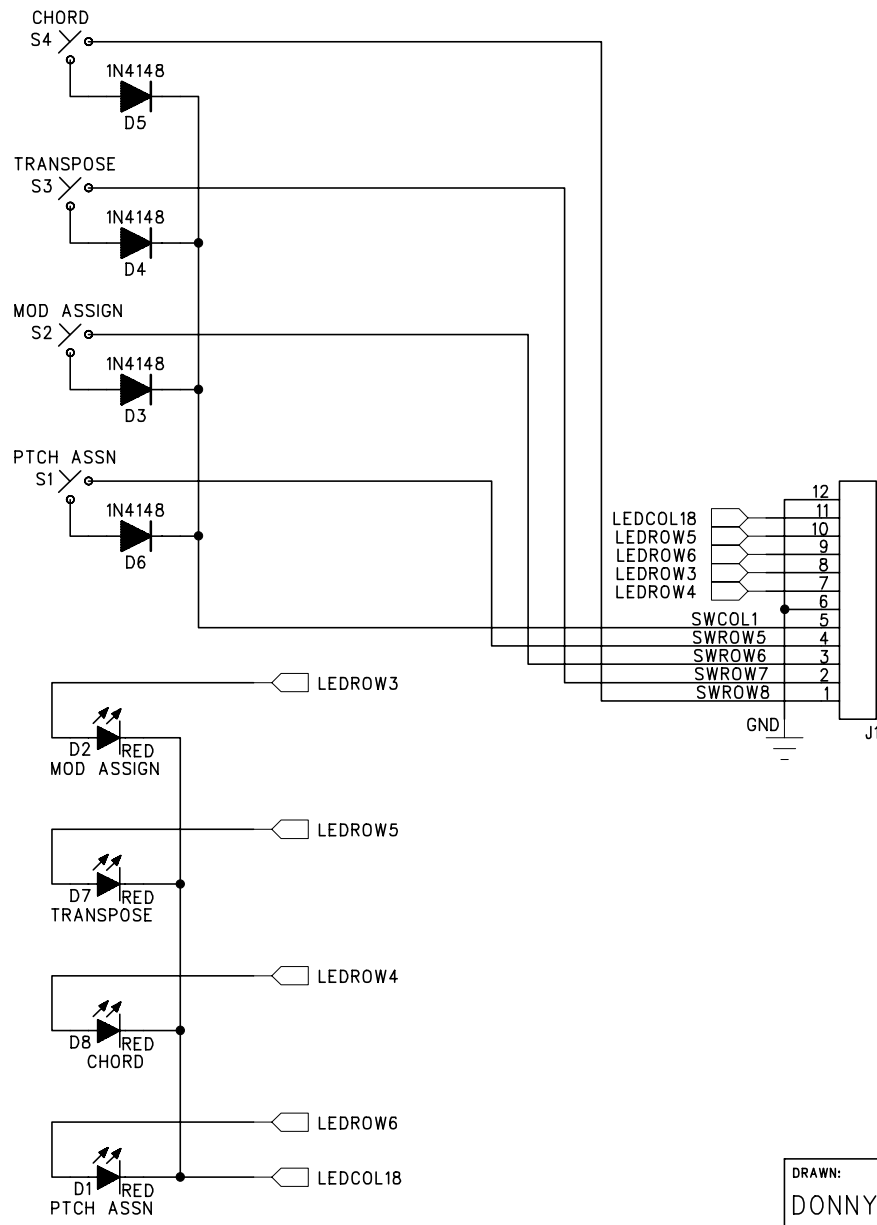

TO FRONT PANEL PCB

COMPANY: ALESIS			
TITLE: A6 P/M Board			
DRAWN: DONNY/CA/JG	DATED: 6/30/00	PART NUMBER: 9-40-0204-A	REV: A
RELEASED:	DATED:	ASSY NUMBER: 9-79-0204	SIZE: A
SCALE:		FILENAME: A6PMA01A.SCH	SHEET: 1 OF 1

ALESIS ASSEMBLY DRAWING 9-79-0204-A

ALESIS 9-40-0204-A TOPSILK

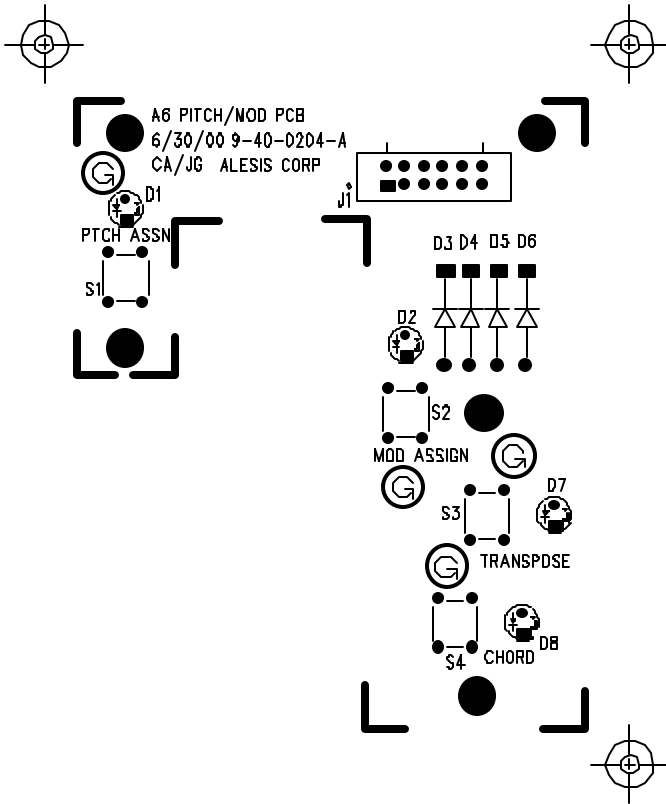

1. Hand stuff all thru hole components on top (non-trace) side and make sure they are flush (flat) against the PCB. Diodes (2-D2-414B) excluded.
2. All components are soldered on the bottom (trace) side.
3. Hand solder the staked end of cable J1 (4-70-1205-B) and allow cable to roll off top of PCB.
4. Refer to drawings (see below) for assembling and inserting LEDs and spacers. Insert LED with spacer flush against PCB.
5. All LEDs are green (3-D2-0021)
6. VERY IMPORTANT: SWITCHES (6-02-D050) AND LED ASSEMBLIES (SEE BELOW) MUST BE PERFECTLY FLUSH (FLAT) AGAINST THE PCB

ASSEMBLY NDTE FOR PART # 3-D2-0021.

Before soldering, place LED on top of

SPACER (5-03-0018)

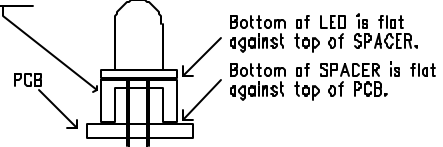

LED LEGEND

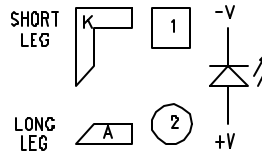

ALLESIS 9-40-0504-A BOTTRACE

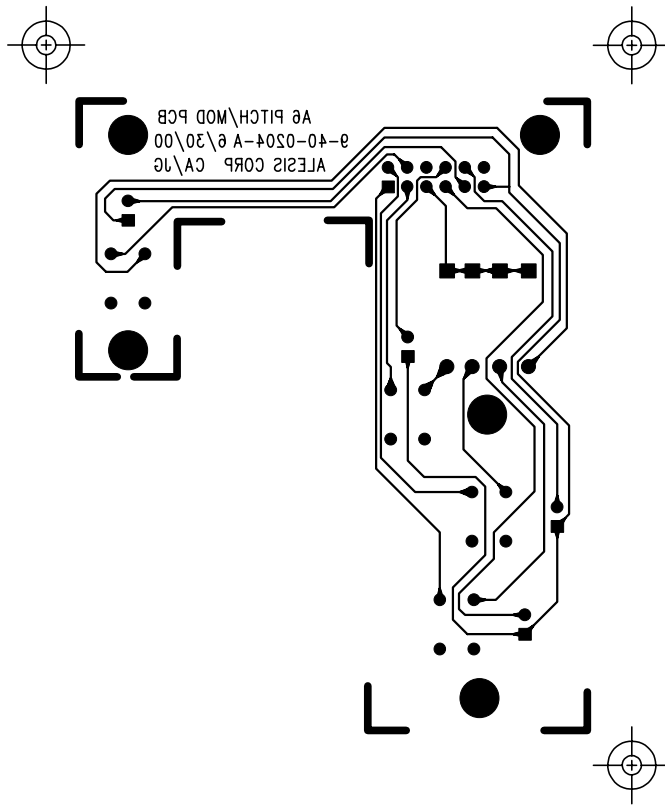

ALESIS 9-40-0204-A TOPTRACE

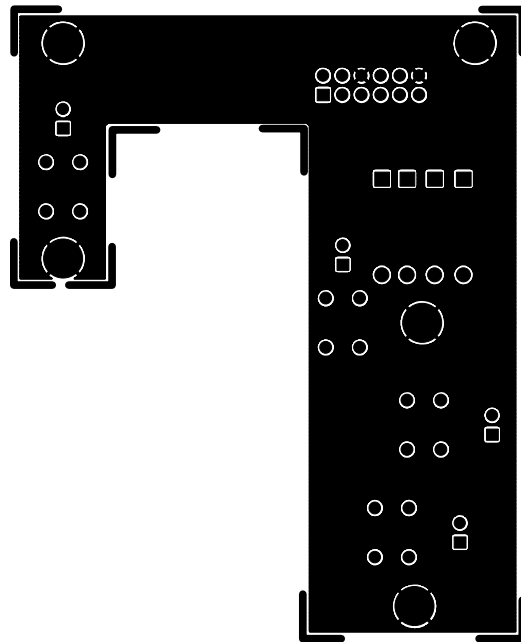

6

5

4

3

2

1

REVISION RECORD			
LTR	ECD NO:	APPROVED:	DATE:

9-40-BA0* OUTPUT VOLTAGES:												
9-79-	V1	I1	V2	I2	V3	I3	R19	R25	D10	D12	T1	L1
BA01	+5	2.0	+12	1.8	-13	0.08	12k1	100	5V6	17V	7-40-0027	7-30-0022
BA02	+7	3.2	+15.5	0.40	-15.5	0.60	26k1	20	8V2	15V	7-40-0029	7-30-0011

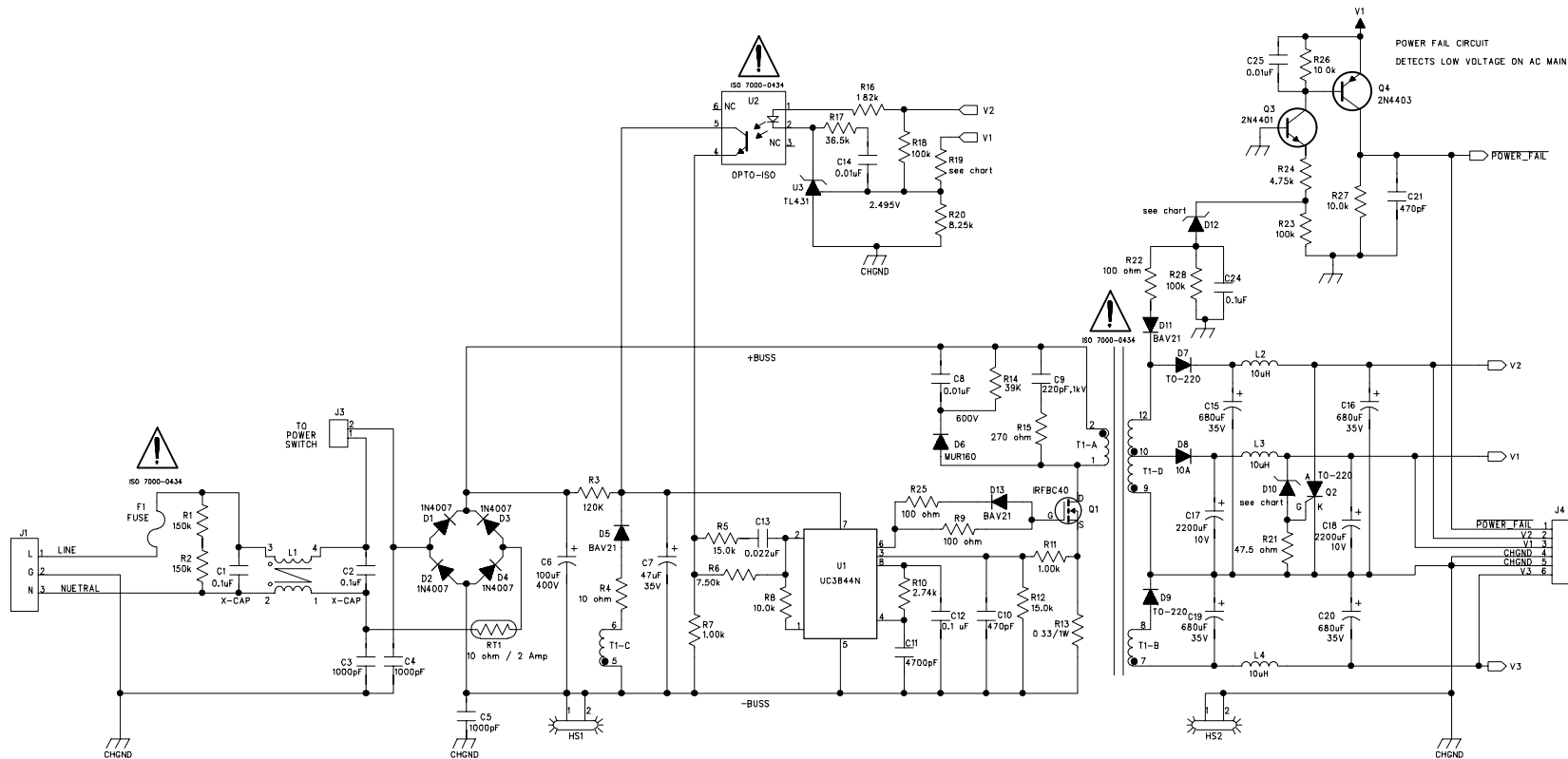

COMPANY:	ALESIS STUDIO ELECTRONICS, INC.		
TITLE:	BA SWITCH-MODE POWER SUPPLY		
PART NUMBER:	9-40-BA01-G	REV:	G
ASSY NUMBER:	9-79-BA01		
FILENAME:	BAMNG03A.SCH	SIZE:	C
SCALE:		SHEET:	1 OF 1

DRAWN:	M-M	DATED:	11/2/01
RELEASED:		DATED:	

ALESIS 9-79-BA01-G "TOP ASSY"

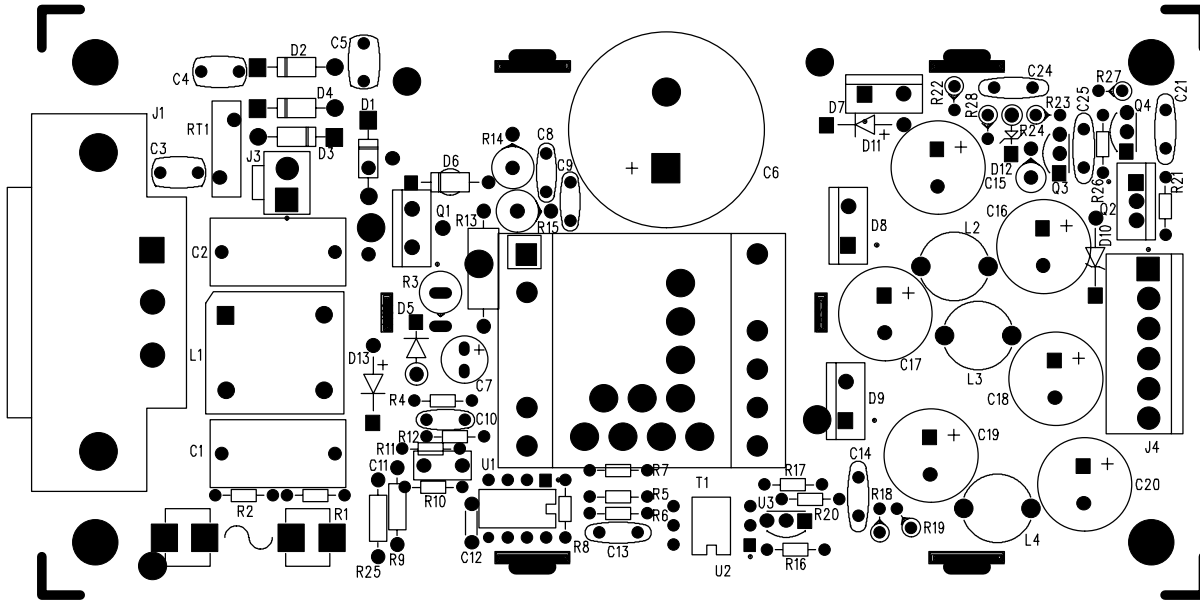

1. Before inserting components:
Write the assembly number and revision onto silkscreened blocks on the PCB using a fine-tipped permanent black marker,
2. Before Wave Soldering:
 - A. Glue the following parts to the top surface of the pcb with a VERY SMALL amount of Cyanoacrylate (Krazy Glue). Do not allow the glue to touch any solderable surfaces such as through-holes. Apply the glue in a thin line following the silkscreen outline of the caps. A fine-tipped applicator is recommended.
C1-2, C6, C15-20 (9 caps) , fuse clips and both heatsinks
 - B. Attach J1 to the pcb with screws (5-02-0036) and kep nuts (5-02-6238) for precision placement before soldering.
 - C. Attach Q1 and D7-9 to heatsink, as per drawing above right, before assembling heatsink to pcb

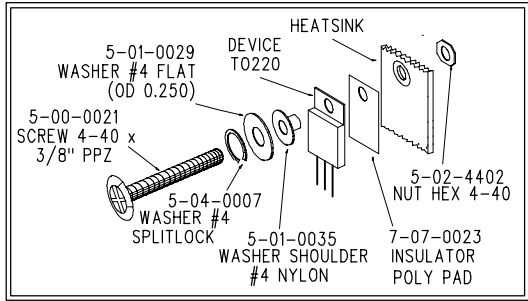

3. After Wave Soldering:
 - A. Apply RTV Silicon to the following components: C16-L2-Q2 and C18-19-20-L3-L4
 - B. Attach all applicable stickers.
Sticker 7-52-0002 to be placed on top of C6.

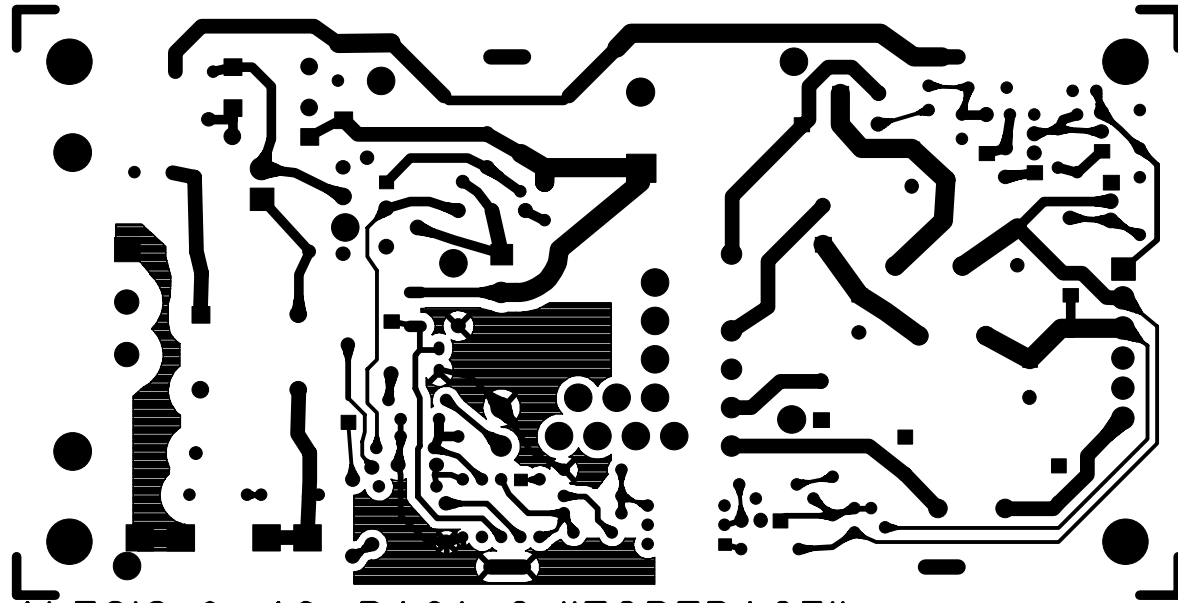

ALESIS 9-40-BA01-G "TOPTRACE"

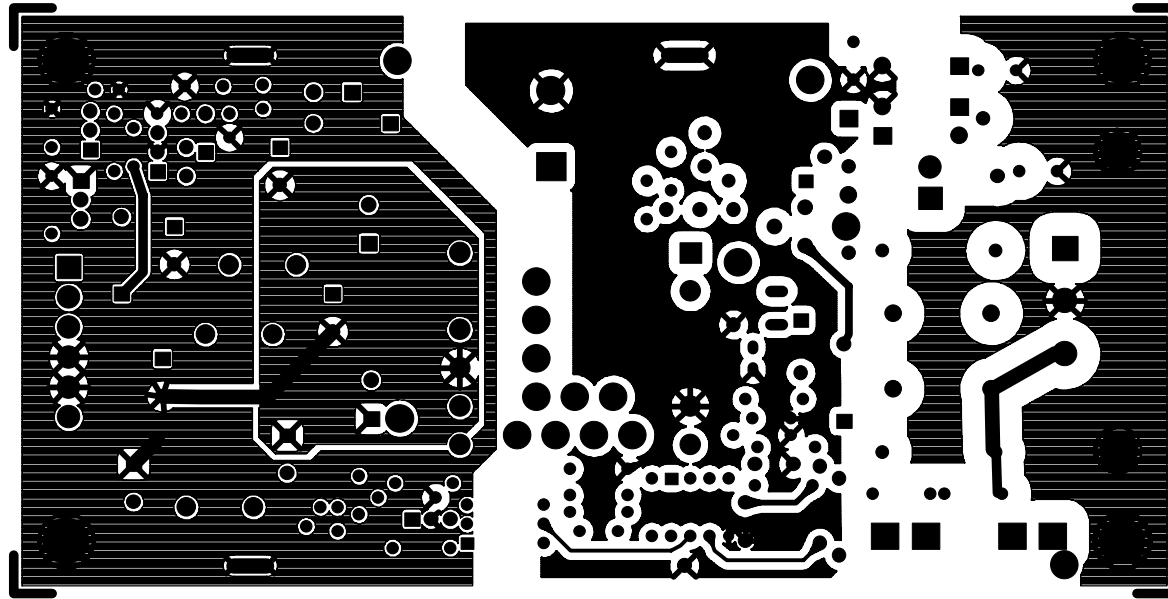

ALESIS 9-40-BA01-G "BOTTRACE"

REVISION RECORD			
LR#	EDD NO	APPROVED	DATE

9-40-BA0* OUTPUT VOLTAGES*												
9-79-	V1	I1	V2	I2	V3	I3	R19	R25	D10	D12	T1	L1
BA01	+5	2.0	+12	1.8	-13	0.80	12k1	100	5V6	17V	7-40-0027	7-30-0022
BA02	+7	3.2	+15.5	0.40	-15.5	0.80	26k1	20	8V2	15V	7-40-0028	7-30-0011

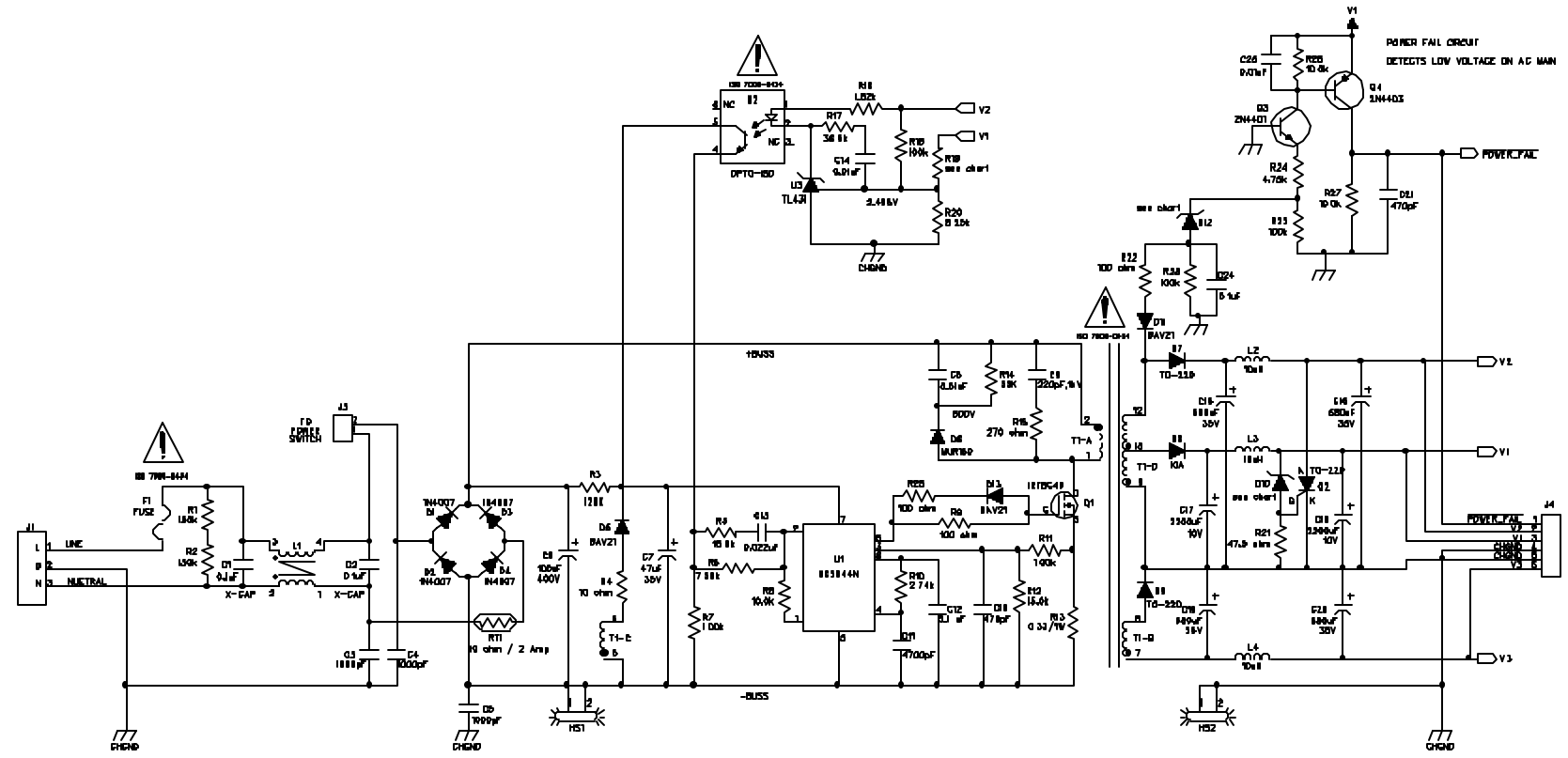

COMPANY	ALEXIS STUDIO ELECTRONICS, INC.		
TITLE	BA SWITCH-MODE POWER SUPPLY		
PART NUMBER	9-40-BA01-H	REV	H
ASSY NUMBER	9-79-BA01		
FILE NAME	BAMNH00A.SCH		
SCALE		SHEET	1 OF 1

DRAWN	M-M	DATE	1/08/02
RELEASE		DATED	

ALESIS 9-79-BA01-H "TOP ASSY"

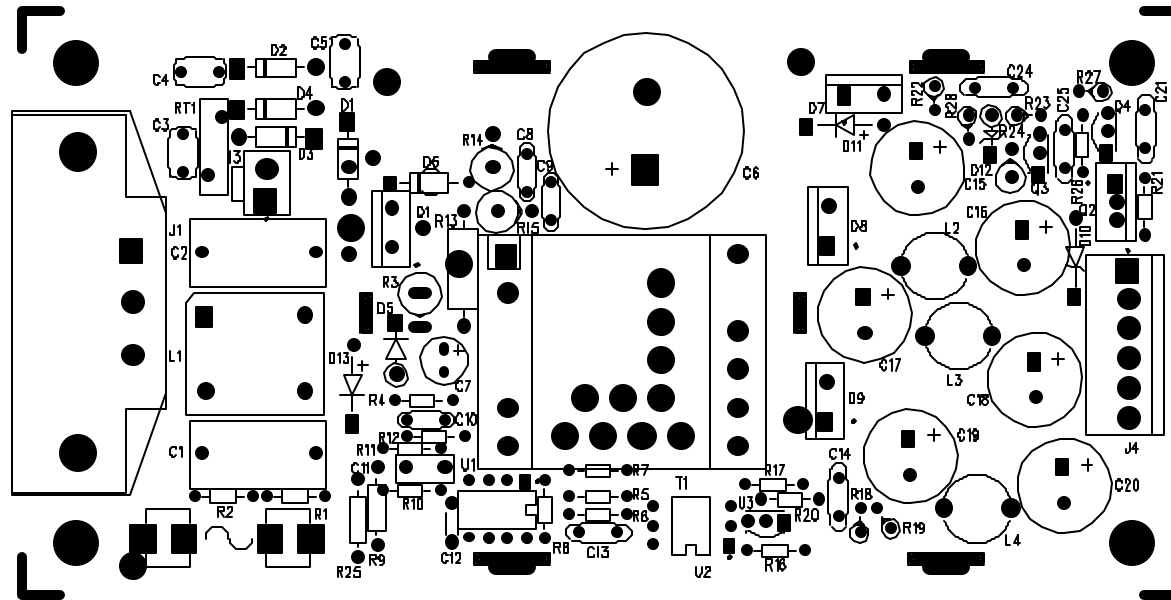

1. Before inserting components:
Write the assembly number and revision into silkscreened blocks on the PCB using a fine-tipped permanent black marker,

2. Before Wave Soldering:

A. Glue the following parts to the top surface of the pcb with a VERY SMALL amount of Cyanacrylate (Krazy Glue). Do not allow the glue to touch any solderable surfaces such as through-holes. Apply the glue in a thin line following the silkscreen outline of the caps. A fine-tipped applicator is recommended.
C1-2, C6, C15-20 (9 caps), fuse clips and both heatsinks

B Attach J1 to the pcb with screws (5-D2-0036) and kep nuts (5-02-623B) for precision placement before soldering.

C. Attach Q1 and D7-9 to heatsink, as per drawing above right, before assembling heatsink to pcb

3. After Wave Soldering:

A. Apply RTV Silicon to the following components: C16-L2-Q2 and C18-19-20-L3-L4

B Attach all applicable stickers

Sticker 7-52-0002 to be placed on top of C6.

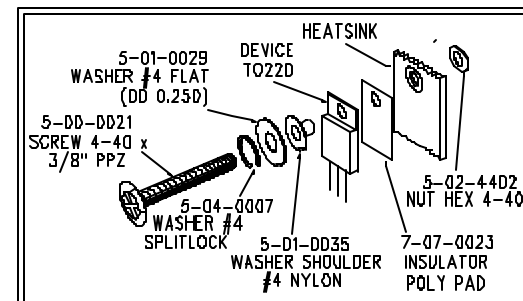

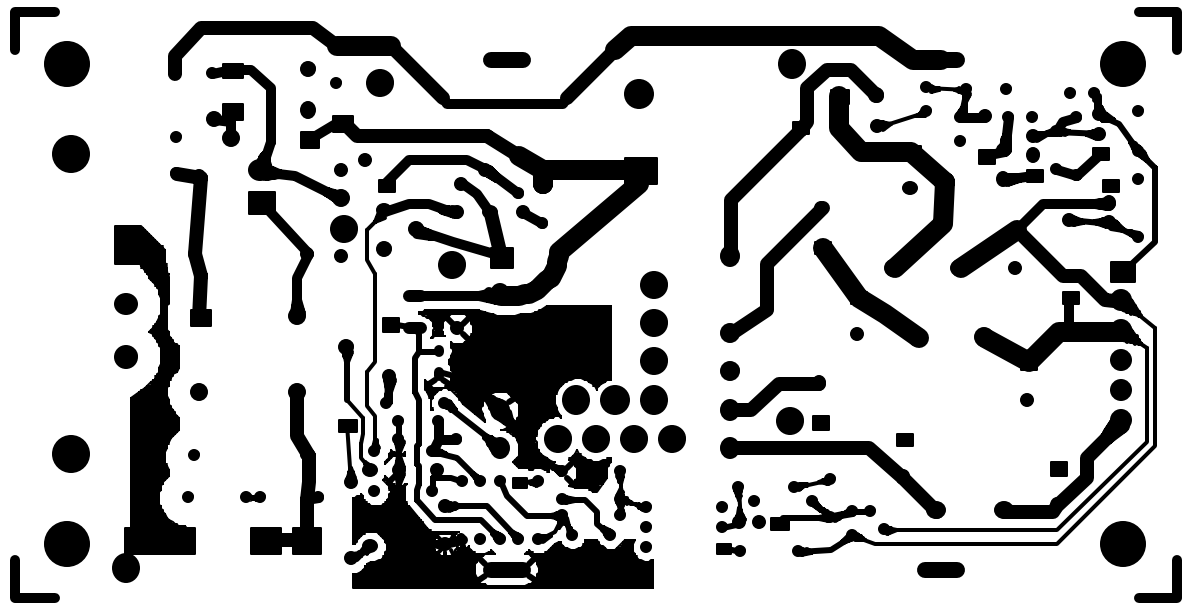

ALESIS 9-40-BA01-H "TOPTRACE"

